

Victaulic® Vic-300 MasterSeal™ Shouldered Butterfly Valve Series 761SC



08.31



Series 761SC
with 10-Position Handle



Series 761SC
with Lever Lock Handle



Series 761SC
with Gear Operator

1.0 PRODUCT DESCRIPTION

Available Sizes

- 2 – 8"/DN50 – DN200.

Maximum Working Pressure

- Accommodates pressures ranging from full vacuum (29.9 in Hg/760 mm Hg) up to 300 psi/2100 kPa/21 bar.
- Full working pressure for bi-directional, dead end services.

Operating Temperature

- Dependent on seat selection from section 3.0.

Application

- For use in carbon steel piping systems.

End Preparation

- Shouldered end pipe.

Actuation Options

- Standard ISO 5211 mounting flange.
- 10-position handle (2 – 6"/DN50 – 165.1 mm).
 - Infinitely variable service with memory stop; Padlockable.
- Lever lock handle (2 – 8"/DN50 – DN200).
 - Infinitely variable service with memory stop; Padlockable.
- Gear operator (2 – 8"/DN50 – DN200).
- Additional 2"/50 mm neck extension available when more than 2"/50 mm of insulation is needed.
- 4 ½"/120 mm-long handle wheel input shaft extension (2 – 8"/DN50 – DN200).

NOTES

- A padlockable valve refers to those valves which can be padlocked to lockout equipment for preventing inadvertent valve operation. When used in conjunction with an appropriate lockout/tagout system, multiple padlocks may be used. The valve may be padlocked either fully open or fully closed.
- A tamper-resistant option is also available, which is meant to deter theft, vandalism or other malicious activity. The handles and associated components are assembled with tamper-resistant fasteners which are designed for one-time assembly. Attempts to defeat the padlock by partial disassembly of the valve will likely result in evidence of such activity. The valve may be padlocked either fully open or fully closed.
- Hand wheel input shaft extensions are not for use with chain wheels.

ALWAYS REFER TO ANY NOTIFICATIONS AT THE END OF THIS DOCUMENT REGARDING PRODUCT INSTALLATION, MAINTENANCE OR SUPPORT.



2.0 CERTIFICATION/LISTINGS

Product designed and manufactured under Victaulic's Quality Management System, as certified by LPCB in accordance with ISO-9001:2008. Valve construction and performance meet or exceed MSS-SP-67 requirements.



3.0 SPECIFICATIONS – MATERIAL

Series 761SC Vic-300 MasterSeal™ Shouldered Butterfly Valve

Body: Ductile iron conforming to ASTM A536, Grade 65-45-12.

End Face, 2 – 6"/DN50 – 165.1 mm: Ductile iron conforming to ASTM A536, Grade 65-45-12.

Seal Retainer, 8"/DN200: Ductile iron conforming to ASTM A536, Grade 65-45-12.

Coating: Black alkyd enamel.

Disc: (specify choice)

Standard: Ductile iron conforming to ASTM A536, Grade 65-45-12, with electroless nickel coating conforming to ASTM B733.

Optional: Stainless steel, conforming to ASTM A351, Grade CF8M.

Optional: 2 – 6"/DN50 – 165.1 mm only – Aluminum bronze, Grade C95500.

Seat: (specify choice)

Victaulic EPDM

EPDM (Green color code). Temperature range –30°F to +230°F/–34°C to +110°C. NOT RECOMMENDED FOR PETROLEUM SERVICES OR STEAM SERVICES.

Victaulic Nitrile

Nitrile (Orange color code). Temperature range +10°F to +150°F/–12°C to +65°C. Not compatible for hot water services over +150°F/+66°C or for hot dry air over +140°F/60°C. NOT RECOMMENDED FOR HOT WATER SERVICES OR STEAM SERVICES.

Victaulic Fluoroelastomer

Fluoroelastomer (Blue color code). Temperature range +20°F to +300°F/–7°C to +149°C. NOT RECOMMENDED FOR HOT WATER SERVICES OR STEAM SERVICES

Stems:

Standard: 416 stainless steel conforming to ASTM A582.

Optional¹: 17-4PH stainless steel conforming to ASTM A564.

Stem Seal Cartridge:

Standard: C36000 brass.

Optional¹: 17-4PH stainless steel conforming to ASTM A564.

¹ Contact Victaulic for available material combination options.

Bearings: Fiberglass and 316 stainless steel with TFE lining.

Stem Seals: Furnished in same materials as seat.

Stem Retaining Ring: Carbon steel.

3.0 SPECIFICATIONS – MATERIAL (CONTINUED)

10 Position Handle:

For sizes 2 – 6"/DN50 – 165.1 mm: Zinc-plated carbon steel handle with zinc-plated carbon steel latch plate and zinc-plated carbon steel fasteners, infinitely variable, padlockable and includes memory stop. Optionally available with tamper-resistant hardware.

Lever Lock Handle

For sizes 2 – 8"/DN50 – DN200: Zinc-plated carbon steel handle with zinc-plated carbon steel latch plate and carbon steel fasteners.

For sizes 2 - 8"/DN50 - DN200: Infinitely variable, padlockable and includes memory stop. Optionally available with tamper-resistant hardware.

Gear Operator (with options below):

Hand wheel with memory stop

Hand wheel with chainwheel

2" square nut

Thermal barrier

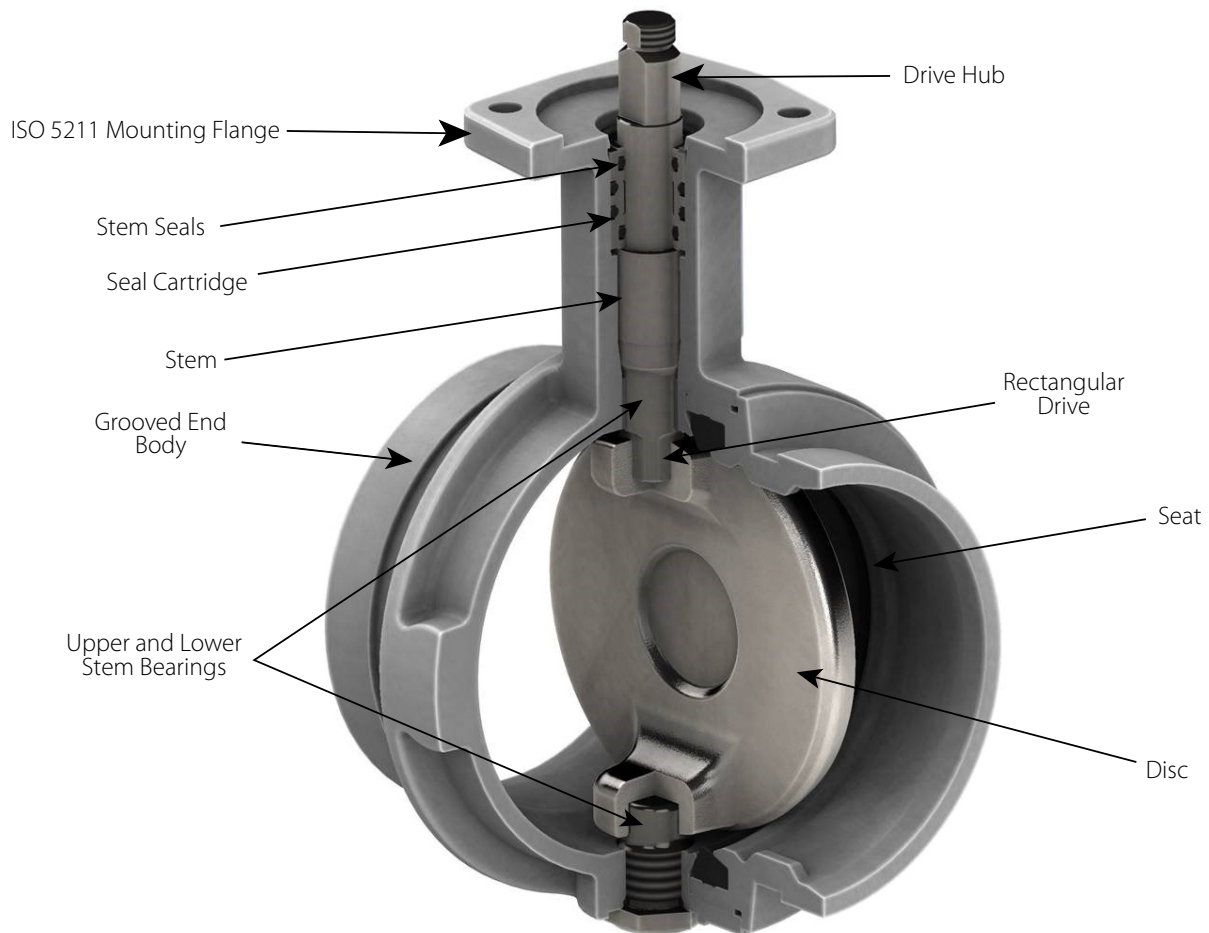

4.0 DIMENSIONS

Series 761SC Vic-300 MasterSeal™ Shouldered Butterfly Valve – Bare Valve

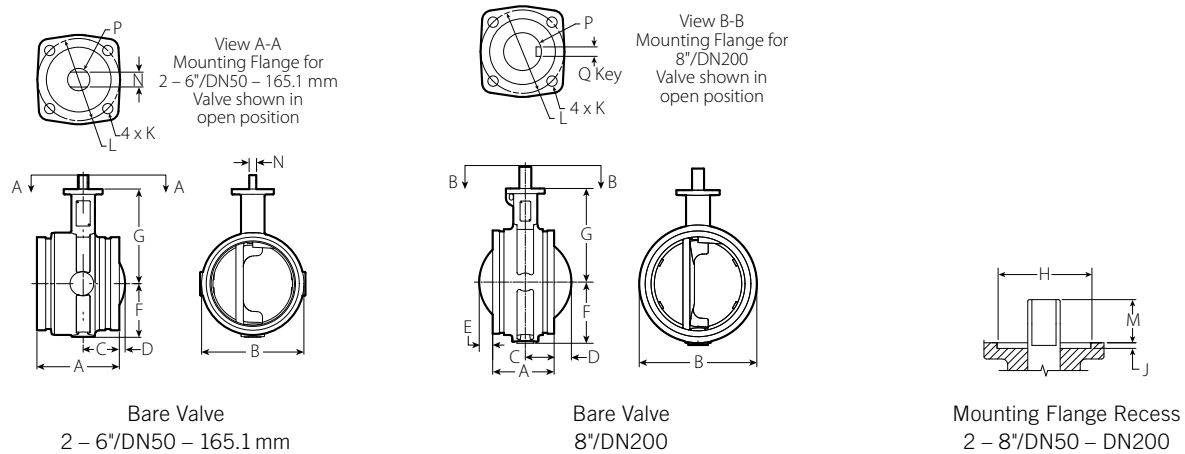

Size		Dimensions								Weight		ISO 5211 Flange Designation
Nominal inches DN	Actual Outside Diameter inches mm	A End to End inches mm	B inches mm	C inches mm	D inches mm	E inches mm	F inches mm	G inches mm	Q-Key inches mm	Approx. (Each) lb kg		
2 DN50	2.375 60.3	3.38 85	3.25 83	1.50 37	– –	– –	1.88 46	3.88 97	– –	3.5 1.6	F07	
3 DN80	3.500 88.9	3.88 97	4.50 114	1.88 45	– –	– –	2.38 60	4.50 114	– –	6.0 2.7	F07	
4 DN100	4.500 114.3	4.75 119	5.50 139	2.25 55	– –	– –	2.88 73	5.25 133	– –	9.3 4.2	F07	
	6.500 165.1	6.00 151	7.38 185	2.63 66	0.50 11	– –	3.88 97	6.75 172	– –	20.0 9.1	F07	
8 DN200	8.625 219.1	5.63 140	10.00 254	2.38 59	1.50 37	0.88 20	5.00 127	8.00 203	0.188 x .88 4.78 x 22.35	34.3 15.6	F07	

Size		Dimensions									Weight		ISO 5211 Flange Designation
Nominal inches DN	Actual Outside Diameter inches mm	A End to End inches mm	H inches mm	J inches mm	K inches mm	L inches mm	M inches mm	N inches mm	P inches mm	Q-Key inches mm	Approx. (Each) lb kg		
2 DN50	2.375 60.3	3.38 85	2.25 55	0.13 3	0.38 9	2.88 70	0.88 22	0.38 8	0.43 11	– –	3.5 1.6	F07	
3 DN80	3.500 88.9	3.88 97	2.25 55	0.13 3	0.38 9	2.88 70	0.88 22	0.38 8	0.50 11	– –	6.0 2.7	F07	
4 DN100	4.500 114.3	4.75 119	2.25 55	0.13 3	0.38 9	2.88 70	0.88 23	0.43 11	0.63 15	– –	9.3 4.2	F07	
	6.500 165.1	6.00 151	2.25 55	0.13 3	0.38 9	2.88 70	1.13 29	0.50 13	0.75 19	– –	20.0 9.1	F07	
8 DN200	8.625 219.1	5.63 140	2.25 55	0.13 3	0.38 9	2.88 70	1.38 33	– –	0.88 22	0.188 x .88 4.78 x 22.35	34.3 15.6	F07	

4.1 DIMENSIONS

Series 761SC Vic-300 MasterSeal™ Shouldered Butterfly Valve – With Handle

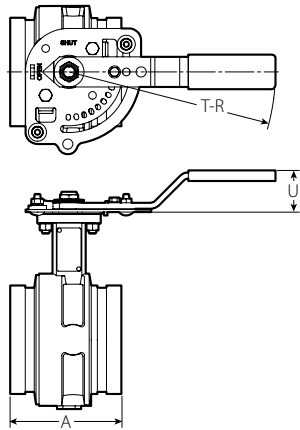

10-Position Handle with Memory Stop
2 – 6"/DN50 – 165.1 mm

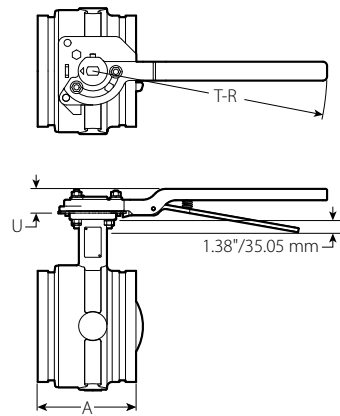

Lever Lock Handle with Memory Stop
2 – 8"/DN50– DN200

Size		Dimensions			Weight - Approx (Each)	
Nominal inches DN	Actual Outside Diameter inches mm	A End to End inches mm	T-R inches mm	U inches mm	Valve with 10-Position Handle inches mm	Valve with Lever Handle lb kg
2	2.375	3.38	7.00	1.63	4.4	6.0
DN50	60.3	85	178	40	2.0	2.7
3	3.500	3.88	7.00	1.63	6.9	8.5
DN80	88.9	97	178	40	3.1	3.9
4	4.500	4.75	8.50	1.63	10.8	11.8
DN100	114.3	119	216	40	4.9	5.4
	6.500	6.00	12.00	1.63	22.0	23.2
	165.1	151	305	40	10.0	10.5
8	8.625	5.63	14.00	1.50	–	37.5
DN200	219.1	140	356	38	–	17.0

4.2 DIMENSIONS

Series 761SC Vic-300 MasterSeal™ Shouldered Butterfly Valve – With Gear Operator

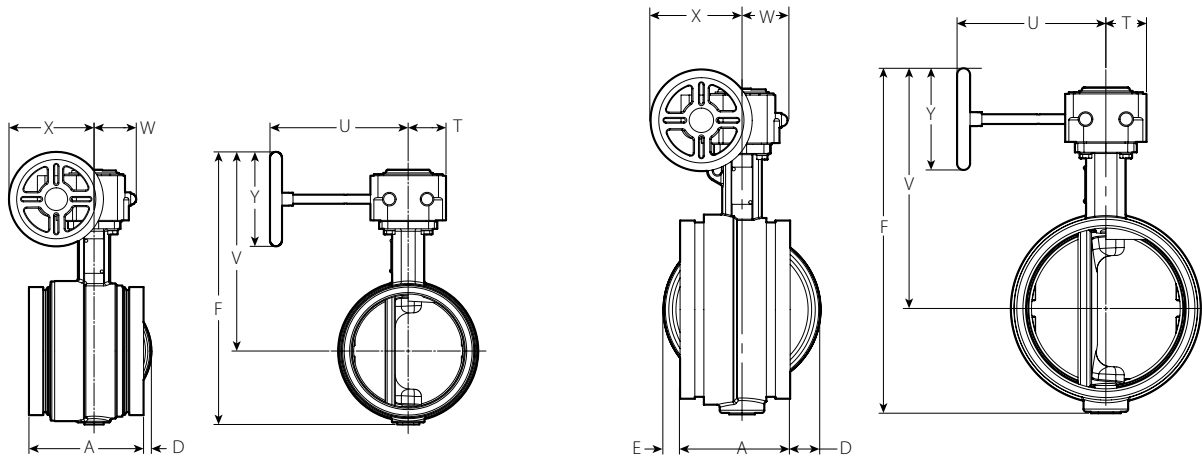

Gear Operator
2 – 6"/DN50 – 165.1 mm

Gear Operator
8"/DN200

Size		Dimensions										Weight
Nominal	Actual Outside Diameter	A End to End	D	E	F	T	U	V	W	X	Y	Approx. (Each)
inches mm	inches mm	inches mm	inches mm	inches mm	inches mm	inches mm	inches mm	inches mm	inches mm	inches mm	inches mm	lb kg
2	2.375	3.38	–	–	8.63	1.63	4.75	6.88	1.88	3.63	4.00	6.0
DN50	60.3	85	–	–	220	40	121	174	48	93	100	2.7
3	3.500	3.88	–	–	9.88	1.63	4.75	7.25	1.88	3.63	4.00	8.5
DN80	88.9	97	–	–	251	40	121	191	48	93	100	3.9
4	4.500	4.75	–	–	11.25	1.63	4.75	8.25	1.88	3.63	4.00	11.8
DN100	114.3	119	–	–	284	40	121	210	48	93	100	5.4
	6.500	6.00	0.50	–	14.13	2.00	7.25	10.25	2.25	4.38	4.88	24.0
	165.1	151	11	–	359	50	183	262	56	113	125	10.9
8	8.625	5.63	1.50	0.88	16.63	2.00	7.25	11.50	2.25	4.38	4.88	38.3
DN200	219.1	140	37	20	423	50	183	294	56	113	125	17.4

4.3 DIMENSIONS

Series 761SC Vic-300 MasterSeal™ Shouldered Butterfly Valve

Accessories

Chainweels

Chainweels are mounted to the gear operator hand wheels. Sprocket rim and guide arms are made of cast aluminum. Chain is galvanized steel.

HOW TO ORDER:

Specify type valve and operator by valve numbering system shown on page 11

Always specify length of chain required.

For insulation and locking device, contact Victaulic for details. Hand wheel input shaft extensions are not for use with chain wheels.

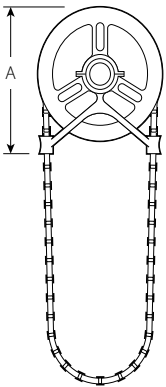

Chain Wheel and Guide
with Safety Cable Kit

Size	Dimensions			Weight
	Sprocket Size inches	Chain Wheel Size (Dia.) inches mm	A inches mm	
Nominal inches mm				Approximate (Each) lb kg
2 – 4 50 – 100	0	4.00 102	4.63 118	2.0 0.9
6 – 8 150 – 200	1	5.75 146	6.38 162	4.0 1.8

5.0 PERFORMANCE

Series 761SC Vic-300 MasterSeal™ Shouldered Butterfly Valve

C_v/K_v values for flow of water at +60°F/+16°C with various disc positions are shown in the table below.

Formulas for C_v/K_v values:

$$\Delta P = \frac{Q^2}{C_v^2}$$

$$Q = C_v \times \sqrt{\Delta P}$$

Where:

Q = Flow (GPM)
 ΔP = Pressure Drop (psi)
 C_v = Flow Coefficient

$$\Delta P = \frac{Q^2}{K_v^2}$$

$$Q = K_v \times \sqrt{\Delta P}$$

Where:

Q = Flow (m³/hr)
 ΔP = Pressure Drop (Bar)
 K_v = Flow Coefficient

Size		C _v	K _v
Nominal inches DN	Actual Outside Diameter inches mm	(Full Open)	(Full Open)
2 DN50	2.375 60.3	115	99
3 DN80	3.500 88.9	440	379
4 DN100	4.500 114.3	820	707
	6.500 165.1	1800	1552
8 DN200	8.625 219.1	3400	2931

5.1 PERFORMANCE





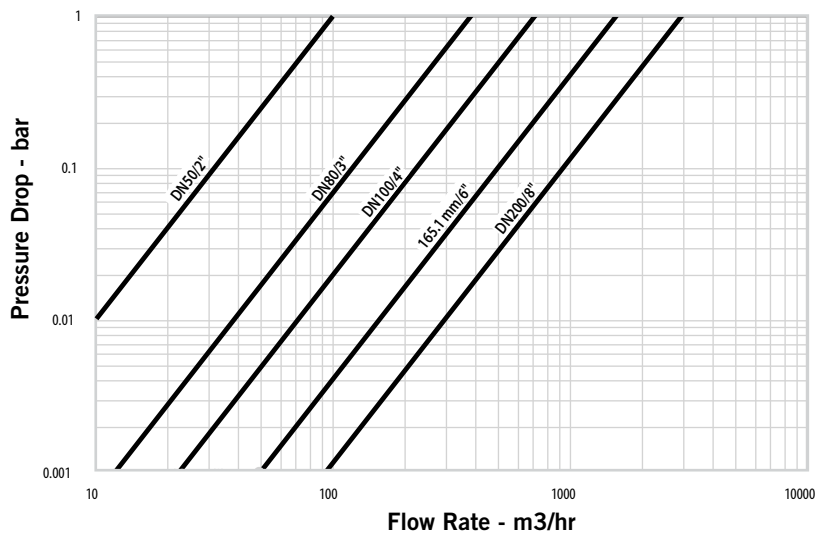
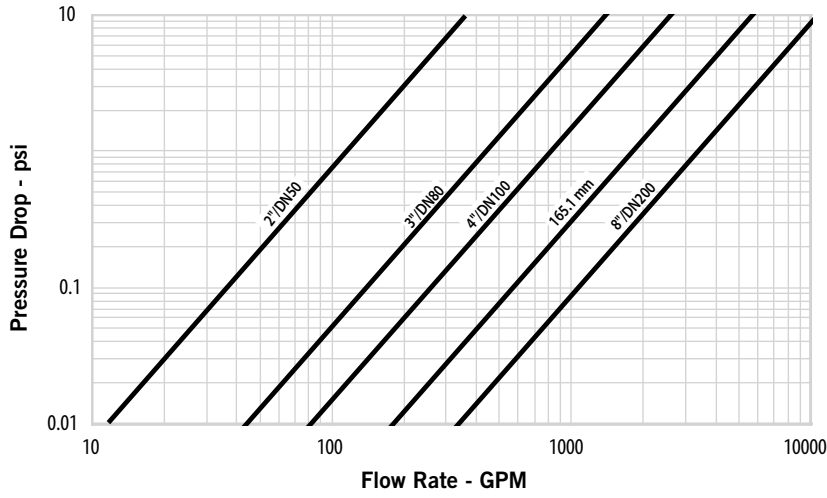

Series 761SC Vic-300 MasterSeal™ Shouldered Butterfly Valve

Flow Characteristics



5.1 PERFORMANCE (CONTINUED)

Series 761SC Vic-300 MasterSeal™ Shouldered Butterfly Valve

Size		Flow Coefficients – Cv/Kv											
Nominal inches DN	Actual Outside Diameter inches mm	Disc Position (Degrees Open)											
		90 		70 		60 		50 		40 		30 	
		Cv	Kv	Cv	Kv	Cv	Kv	Cv	Kv	Cv	Kv	Cv	Kv
2 DN50	2.375 60.3	115	99	60	52	36	31	23	20	14	12	7	6
3 DN80	3.500 88.9	440	379	230	198	140	121	90	78	50	43	26	22
4 DN100	4.500 114.3	820	707	430	321	250	216	160	138	100	86	50	43
	6.500 165.1	1800	1552	940	810	560	483	360	310	220	190	110	95
8 DN200	8.625 219.1	3400	2931	1770	1526	1050	905	670	578	410	353	200	172

Valve Torque Requirements

Size		Torque – Inch Pounds/Newton Meters					
Nominal inches DN	Actual Outside Diameter inches mm	Differential Pressure – psi/bar					
		50/3	100/7	150/10	200/14	232/16	300/21
2 DN50	2.375 60.3	53 6	65 7	78 9	90 10	100 11	115 13
3 DN80	3.500 88.9	150 17	170 19	190 22	210 24	230 26	260 29
4 DN100	4.500 114.3	220 25	250 28	280 32	310 35	330 37	370 42
	6.500 165.1	410 46	470 53	540 61	600 68	640 72	730 83
8 DN200	8.625 219.1	540 61	680 77	820 93	950 107	1040 118	1230 139

Source:

These torque values were derived from test data with non-lubricated valves in water at ambient temperatures with EPDM seals. For other material and service conditions, apply a suitable service factor.

Torque Factors:

All torque values are for normal conditions (i.e., the valve is operated at least once a quarter, disc corrosion is expected to be minor, the media is clean and nonabrasive, and the chemical effects upon the elastomer are minor).

Typical Fluid Torque Factors Commonly Used in the Industry:

Water: 1.0; Lubricated service: 0.8; Dry gases: Lubricated nitrile “T” seat seals may be specified for dry gases wherever chemically appropriate. See material torque factor below.

Material Torque Factors:

EPDM = 1.0; Fluoroelastomer = 1.2; Nitrile = 0.8

Cycling Factor:

Valve torque will typically increase and actuator output decrease as the valve is cycled. A factor of 1.5 should be applied for when total valve cycles are expected to exceed 5,000.

5.1 PERFORMANCE (CONTINUED)

Actuation Factor:

A factor should be added to account for potential drift in the output of the actuator due to actuator performance, misalignment or external inputs (i.e., air or power supply). For this, a factor of up to 1.25 may be used.

Combining Torque Factors:

When multiple torque factors apply, they are combined by multiplying them. Example: For an EPDM seal and a 5,000 cycle factor the combined factor would be $1.0 \times (1.5) = 1.5$.

NOTE

- Under certain high flow conditions, the hydrodynamic torque can exceed the seating torque. Large butterfly valves are not recommended for use in a free discharge condition, such as filling an empty line with fluid at the full rated pressure.
- Contact Victaulic for other services.

5.2 PERFORMANCE

Series 761SC Vic-300 MasterSeal™ Shouldered Butterfly Valve

Typical Specifications

Butterfly valves 2 – 8"/DN50 – DN200 shall be rated to 300 psi/2068 kPa/21 bar and be suitable for bi-directional and dead-end service from full vacuum to full-rated pressure. Body material shall be ductile iron with blowout proof stainless steel stems and electroless nickel coated ductile iron disc. Seat material shall be EPDM, lubricated nitrile or fluoroelastomer, and have a full 360° continuous contact with the seating surface. Stem seals shall be of the same material grade as the seats. Disc shall be offset from the centerline of the stems and shall be connected to the stem without the use of fasteners or pins. Valve ends shall be shouldered. Valve shall have standard ISO flange mounting for ease of actuation. Operators shall be as specified by choice in valve table. The standard handle valve 2 – 8"/DN50 – DN200 shall include latch lock, infinitely variable and memory stop features. Manufacturer – Victaulic – Series 761SC Vic-300 MasterSeal Valve or approved equal.

Numbering System

Type	Actual OD in/mm	Size Code	Series	Disc/Stem	Seat	Operator
V	2.375/60.3	603	761	S - Ductile Iron/416SS	E - EPDM	2 - 10-Position handle with memory stop
	3.500/88.9	889			T - Lubricated Nitrile	3 - Gear operator
	4.500/114.3	114				8 - Lever lock with tamper resistant device
	6.500/165.1	165				9 - Gear operator with memory stop
	8.625/219.1	219				

5.2 PERFORMANCE (CONTINUED)

Important Installation Considerations

When installing a Victaulic butterfly valve into a piping system, follow the instructions supplied with the coupling. Refer to the notes below for applications/limitations.

When using butterfly valves for throttling service, Victaulic recommends the disc be positioned no less than 30 degrees open. For best results, the disc should be between 30 and 70 degrees open. High pipeline velocities and/or throttling with the disc less than 30 degrees open may result in noise, vibration, cavitation, severe line erosion, and/or loss of control. For details regarding throttling services, contact Victaulic.







Victaulic recommends that flow velocities for water service are limited to 10 ft. per sec./3 m per sec. When higher flow velocities are necessary, contact Victaulic. When dealing with flow media other than water, contact Victaulic.

Victaulic recommends good piping practices and installing the valve five pipe diameters downstream of sources of irregular flow, such as pumps, elbows and control valves. If not practical due to space constraints, the system should be designed to locate and orient the valve to minimize the impact of dynamic torque and valve life.



DO NOT INSTALL BUTTERFLY VALVES INTO THE SYSTEM
WITH THE DISC IN THE FULLY OPEN POSITION.

6.0 NOTIFICATIONS

 WARNING					
					
<ul style="list-style-type: none">• Read and understand all instructions before attempting to install, remove, adjust, or maintain any Victaulic piping products.• Depressurize and drain the piping system before attempting to install, remove, adjust, or maintain any Victaulic piping products.• Wear safety glasses, hardhat, and foot protection. <p>Failure to follow these instructions could result in death or serious personal injury and property damage.</p>					

7.0 REFERENCE MATERIALS

[I-100: Victaulic Field Installation Handbook](#)

[I-SC77: Victaulic Style SC77 Installation-Ready™ Coupling for Shouldered Pipe Installation Instructions](#)

[I-SC85: Victaulic Style SC85 Coupling for Shouldered Pipe Installation Instructions](#)

[I-VIC300MS: Victaulic Vic-300 MasterSeal™ Butterfly Valve Series 761/461 Installation and Maintenance Manual](#)

User Responsibility for Product Selection and Suitability

Each user bears final responsibility for making a determination as to the suitability of Victaulic products for a particular end-use application, in accordance with industry standards and project specifications, and the applicable building codes and related regulations as well as Victaulic performance, maintenance, safety, and warning instructions. Nothing in this or any other document, nor any verbal recommendation, advice, or opinion from any Victaulic employee, shall be deemed to alter, vary, supersede, or waive any provision of Victaulic Company's standard conditions of sale, installation guide, or this disclaimer.

Intellectual Property Rights

No statement contained herein concerning a possible or suggested use of any material, product, service, or design is intended, or should be construed, to grant any license under any patent or other intellectual property right of Victaulic or any of its subsidiaries or affiliates covering such use or design, or as a recommendation for the use of such material, product, service, or design in the infringement of any patent or other intellectual property right. The terms "Patented" or "Patent Pending" refer to design or utility patents or patent applications for articles and/or methods of use in the United States and/or other countries.

Note

This product shall be manufactured by Victaulic or to Victaulic specifications. All products to be installed in accordance with current Victaulic installation/assembly instructions. Victaulic reserves the right to change product specifications, designs and standard equipment without notice and without incurring obligations.

Installation

Reference should always be made to the Victaulic installation handbook or installation instructions of the product you are installing. Handbooks are included with each shipment of Victaulic products, providing complete installation and assembly data, and are available in PDF format on our website at www.victaulic.com.

Warranty

Refer to the Warranty section of the current Price List or contact Victaulic for details.

Trademarks

Victaulic and all other Victaulic marks are the trademarks or registered trademarks of Victaulic Company, and/or its affiliated entities, in the U.S. and/or other countries.