

Victaulic® Discharge CBV Vibration Isolation Pump Drop Series 383/383G



1.0 PRODUCT DESCRIPTION

Available Sizes

- 3 – 12"/DN80 - DN300
- Offered with multiple size reductions; see section 4.0 for available options.

Maximum Working Pressure

- Rated to the working pressure of the flange connection up to a maximum of 300 psi/2068 kPa/21 bar

Temperature Range

- –30°F to +230°F/–34°C to +110°C

End Preparation (specify choice)

Series 383: 3 – 12"/DN80 – DN300: Class 150 flange

Series 383G: 4 – 8"/DN100 – DN200: Original Groove System (OGS)

Application

- This Discharge CBV Vibration Isolation Pump Drop connects a pump to the interconnecting pipe/discharge header in the mechanical room.
- Provides noise reduction, expansion, contraction and deflection.
- Provides reverse flow protection and balancing functionality.

ALWAYS REFER TO ANY NOTIFICATIONS AT THE END OF THIS DOCUMENT REGARDING PRODUCT INSTALLATION, MAINTENANCE OR SUPPORT.



1.0 PRODUCT DESCRIPTION (CONTINUED)

Vibration Attenuation Performance

- The following charts show the relative **vibration attenuation characteristics** of the Series 383/383G Vibration Isolation Pump Drop compared to double sphere rubber connectors and stainless steel braided pump connectors, respectively, for typical HVAC pump speeds.
- For all sizes shown, the vibration attenuation provided by the Series 383/383G exceeds the vibration attenuation characteristics of the other products tested, for typical HVAC pump speeds.

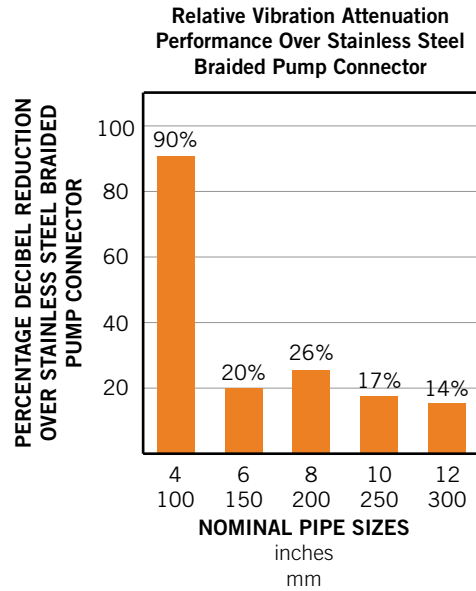
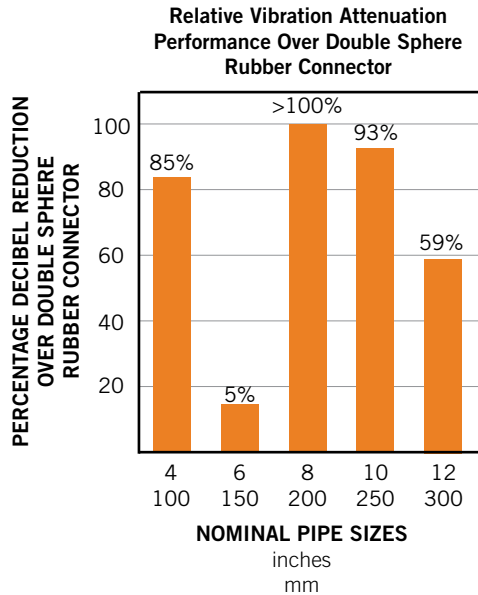

- Additionally, the Series 383/383G provides **linear movement and angular deflection capabilities**, along with the ability to **accommodate piping misalignment**, which should reduce stresses at pump or equipment connections.
- The use of either cut grooved or roll grooved pipe offers the same vibration attenuation characteristics.

NOTE

- For more information, please refer to [publication 26.04](#): Victaulic Couplings Vibration Attenuation Characteristics.

2.0 CERTIFICATION/LISTINGS

Product designed and manufactured under the Victaulic Quality Management System, as certified by LPCB in accordance with ISO-9001:2015.

3.0 SPECIFICATIONS – MATERIAL

- Standard weight carbon steel conforming to ASTM A53 Grade B.
- Victaulic Original Groove System (OGS).
- Standard orange coating.
- Gaskets: EPDM.
- Bolts/Nuts: Carbon steel oval neck track bolts meeting the mechanical property requirements of ASTM A449. Carbon steel heavy hex nuts meeting the mechanical property requirements of ASTM A563 Grade B. Track bolts and heavy hex nuts are zinc electroplated per ASTM B633 Fe/Zn5, finish Type III (imperial) or Type II (metric).

Ductile iron Y-pattern globe style balancing valve: Body conforming to ASTM A536, Grade 60-40-18 (BS Grade 400/15).

Body Coating: Sizes 3 – 8"/DN80 - DN200: Epoxy painted; Sizes 10 - 12"/DN250 – DN300: Painted.

Trim (Bonnet, Stem and Restriction Cone)

Bonnet: Sizes 3 – 6"/DN80 – DN150: AMETAL®; Sizes 8 – 12"/DN200 – DN300: Ductile iron.

Sizes 3 – 6"/DN80 – DN150 Stem & Restriction Cone: AMETAL®.

Sizes 8 – 12"/DN200 – DN300: Cone – Ductile iron; Spindle – AMETAL®.

Seat: Ductile iron.

Seat Seal: EPDM.

Stem Seal: EPDM.

Probe Seal: EPDM.

Handwheel: Sizes 3 – 6"/DN80 - DN150: Red polyamide plastic; Sizes 8 – 12"/DN200 – DN300: Aluminum.

Ductile iron check valve: Conforming to ASTM A536, Grade 65-45-12, black coating.

Body Seat: Size 3"/DN80: O-ring installed into an electroless nickel plating conforming to ASTM 8733.

Seat: EPDM.

Disc: Size 3"/DN80: CF8M cast stainless steel; Sizes 4 – 12"/DN100 – DN300: Ductile iron conforming to ASTM A536, Grade 65-45-12, fully encapsulated in Grade EPDM elastomer.

Shaft: Size 3"/DN80: Brass; Sizes 4 – 12"/DN100 – DN300: Type 316 stainless steel.

Spring: Type 302/304 stainless steel.

Shaft Plug: Size 3"/DN80: Type 416 stainless steel; Sizes 4 – 12"/DN100 – DN300: Carbon steel zinc plated to ASTM 8633.

Pipe Plug: Size 3"/DN80: Carbon steel zinc plated.

1 1/4" – 18 UNEF Female Thermometer Connection (Fits most commercially available thermometers with the well removed).

NOTE

- 3/4" female NPT thermometer connection also available. Contact Victaulic for more information.

Pressure Gauge Connection: 3/4" NPT outlet.

Drain Connection: 3/4" NPT outlet (Horizontal discharge VIPDs only)

4.0 DIMENSIONS

Series 383 Vertical Discharge CBV Vibration Isolation Pump Drop Class 150 Flanged End Connection

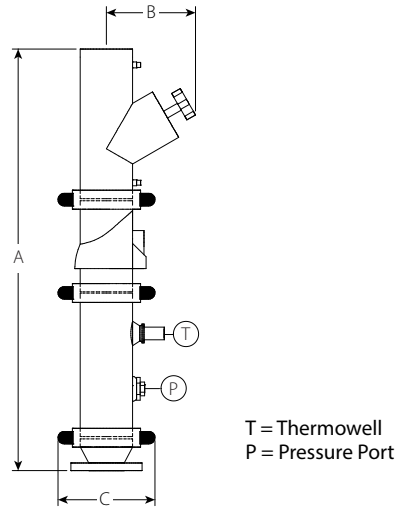

Vertical Pump Installation

Size Nominal inches DN Flange Inlet x Valve Outlet	Dimensions			Weight Approximate (Each) lb ¹ kg
	A inches mm	B inches mm	C inches mm	
3 DN80 x 2 DN50	37.00 940	8.63 219	6.80 172.7	57.2 25.9
	37.00 940	8.63 219	6.80 172.7	50.8 23.0
	34.25 870	8.63 219	6.80 172.7	59.9 27.0
4 DN100 x 2 DN50	39.13 994	9.44 240	7.90 200.7	81.1 36.8
	39.13 994	9.44 240	7.90 200.7	85.1 38.6
	39.13 994	9.44 240	7.90 200.7	87.1 39.5
	35.88 911	9.44 240	7.90 200.7	76.8 34.8
5 x 2½	46.00 1168	10.88 276	9.50 241.3	119.7 54.3
	46.00 1168	10.88 276	9.50 241.3	122.4 55.5
	45.50 1156	10.88 276	9.50 241.3	127.9 58.0
	41.75 1061	10.88 276	9.50 241.3	109.7 49.8
6 DN150 x 2½	53.13 1349	11.25 286	10.90 276.9	196.6 89.2
	53.13 1349	11.25 286	10.90 276.9	166.1 75.3
	53.25 1353	11.25 286	12.25 311	161.5 73.3
	53.25 1353	11.25 286	12.25 311	162.6 73.8
	48.94 1243	11.25 286	12.25 311	150.1 68.1

¹ Estimated weight using standard weight pipe.

4.0 DIMENSIONS (CONTINUED)

Series 383 Vertical Discharge CBV Vibration Isolation Pump Drop
Class 150 Flanged End Connection

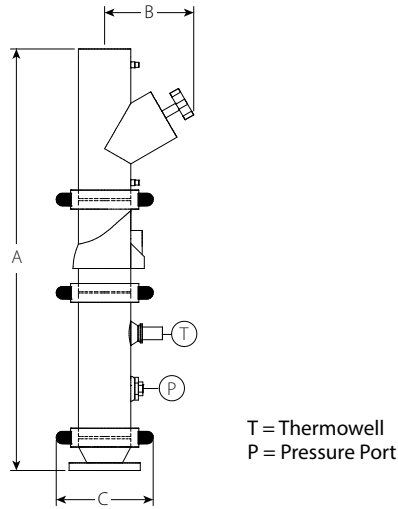

Vertical Pump Installation

Size		Dimensions			Weight	
Nominal inches DN Flange Inlet x Valve Outlet		A inches mm	B inches mm	C inches mm	Approximate (Each) lb ¹ kg	
8 DN200	x	4 DN100	67.50 1715	16.94 430	15.13 384	291.2 132.1
		5	67.50 1715	16.94 430	15.13 384	292.8 132.8
		6 DN150	67.50 1715	16.94 430	15.13 384	294.4 133.5
		8 DN200	62.19 1580	16.94 430	15.13 384	278.7 126.4
		10 DN250	81.94 2081	17.69 449	17.13 435	530.9 240.8
10 DN250	x	8 DN200	81.94 2081	17.69 449	17.13 435	539.6 244.8
		10 DN250	75.94 1929	17.69 449	17.13 435	497.4 225.6
		12 DN300	96.19 2443	18.94 481	19.25 489	724.6 328.7
12 DN300	x	10 DN250	96.19 2443	18.94 481	19.25 489	719.2 326.2
		12 DN300	89.13 2264	18.94 481	19.25 489	671.7 304.7

¹ Estimated weight using standard weight pipe.

4.1 DIMENSIONS

Series 383G Vertical Discharge CBV Vibration Isolation Pump Drop

OGS Grooved End Connection

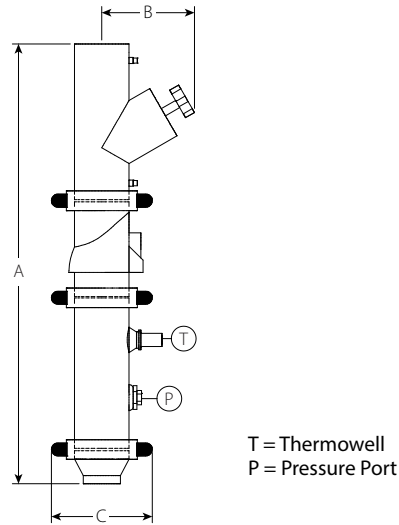

Vertical Pump Installation

Size				Dimensions			Weight
Nominal inches DN		Actual Outside Diameter inches DN		A inches mm	B inches mm	C inches mm	Approximate (Each) lb ¹ kg
Groove Inlet x Valve Outlet		Groove Inlet x Valve Outlet					
4	x	4		35.94	9.44	9.50	76.8
DN100		DN100		913	240	241	34.8
5	x	4		45.56	10.88	11.31	127.9
		DN100		1157	276	287	58.0
6	x	4		53.25	11.25	12.25	161.5
DN150		DN100		1353	286	311	73.3
		6		48.94	11.25	12.25	150.1
		DN150		1243	286	311	68.1
8	x	4		67.50	16.94	15.13	291.2
DN200		DN100		1715	430	384	132.1
		6		67.50	16.94	15.13	294.4
		DN150		1715	430	384	133.5
		8		62.19	16.94	15.13	278.7
		DN200		1580	430	384	126.4
10	x	6		81.94	17.69	17.13	530.9
DN250		DN150		2081	449	435	240.8
		8		81.94	17.69	17.13	539.6
		DN200		2081	449	435	244.8
12	x	8		96.19	18.94	19.25	724.6
DN300		DN200		2443	481	489	328.7

¹ Estimated weight using standard weight pipe.

4.2 DIMENSIONS

Series 383 Horizontal Discharge CBV Vibration Isolation Pump Drop

Class 150 Flanged End Connection

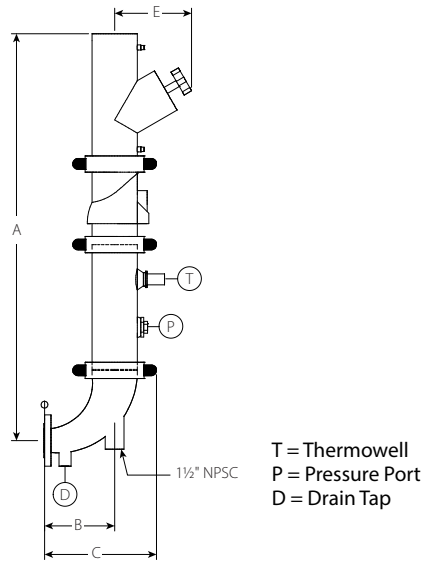

Horizontal Pump Installation

Size		Dimensions				Weight
Nominal inches		A	B	C	E	Approximate (Each)
DN	Flange Inlet x Valve Outlet	inches	inches	inches	inches	lb ¹
		mm	mm	mm	mm	kg
3 DN80	x 2 DN50	40.19	5.75	9.50	8.63	66.0
		1021	146	241	219	29.9
	2 1/2	40.19	5.75	9.50	8.63	68.6
		1021	146	241	219	31.1
4 DN100	x 3 DN80	40.19	5.75	9.50	8.63	66.3
		1021	146	241	219	30.0
	2 1/2	43.44	7.25	12.00	9.44	96.3
		1103	184	305	240	43.7
5	x 3 DN80	43.50	7.25	12.00	9.44	99.0
		1105	184	305	240	44.9
	4 DN100	43.44	7.25	12.00	9.44	94.8
		1103	184	305	240	43.0
6 DN150	x 2 1/2	43.50	7.25	12.00	9.44	93.5
		1105	184	305	240	42.4
	3 DN80	53.00	7.25	12.94	10.88	129.9
		1346	184	329	276	58.9
6 DN150	x 4 DN100	53.00	7.25	12.94	10.88	146.9
		1346	184	329	276	66.6
	5 ²	50.81	8.75	14.44	10.88	135.1
		1291	222	367	276	61.3
6 DN150	x 2 1/2	51.31	9.25	14.94	10.88	124.3
		1303	235	379	276	56.4
	3 DN80	60.63	7.25	13.38	11.25	230.4
		1540	184	340	286	104.5
	4 DN100	59.44	10.25	16.38	11.25	180.8
		1510	260	416	286	82.0
5	59.50	10.25	16.38	11.25	171.8	
	1511	260	416	286	77.9	
6 DN150	59.50	10.25	16.38	11.25	178.1	
	1511	260	416	286	80.8	
6 DN150	x 6 DN150	59.50	10.25	16.38	11.25	191.3
		1511	260	416	286	86.8

¹ Estimated weight using standard weight pipe.

² This size of the Series 383 horizontal discharge CBV VIPD uses a standard long radius elbow, which does not include a base support and a drain.

4.2 DIMENSIONS (CONTINUED)

Series 383 Horizontal Discharge CBV Vibration Isolation Pump Drop Class 150 Flanged End Connection

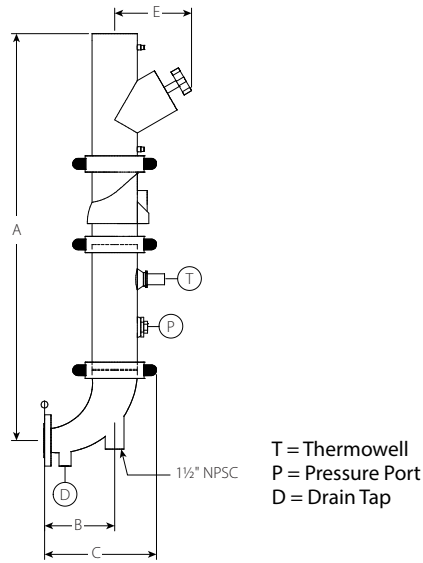

Horizontal Pump Installation

Size		Dimensions				Weight
Nominal inches DN Flange Inlet x Valve Outlet		A inches mm	B inches mm	C inches mm	E inches mm	Approximate (Each) lb ¹ kg
8 DN200	x DN100	76.00	13.50	21.06	16.94	315.0
		1930	343	535	430	142.9
		76.00	13.50	21.06	16.94	318.1
		1930	343	535	430	144.3
		76.00	13.50	21.06	16.94	312.4
10 DN250	x DN150	92.44	16.50	25.06	17.69	648.4
		2348	419	637	449	294.1
		92.44	16.50	25.06	17.69	572.0
12 DN300	x DN200	108.75	19.50	29.13	18.94	815.6
		2762	495	740	481	369.9
		108.75	19.50	29.13	18.94	836.9
		2762	495	740	481	379.6
12 DN300	x DN250	108.69	19.50	29.13	18.94	854.1
		2761	495	740	481	387.4

¹ Estimated weight using standard weight pipe.

4.3 DIMENSIONS

Series 383G Horizontal Discharge CBV Vibration Isolation Pump Drop

OGS Grooved End Connection

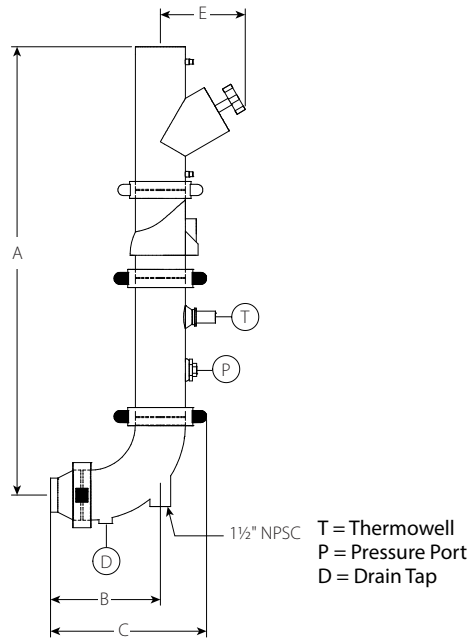

Horizontal Pump Installation

Size				Dimensions				Weight
Nominal inches DN		Actual Outside Diameter inches DN		A inches mm	B inches mm	C inches mm	E inches mm	Approximate (Each) lb ¹ kg
Groove Inlet x Valve Outlet		Groove Inlet x Valve Outlet						
4 DN100	x	4 DN100		43.50 1105	7.25 184	12.00 305	9.44 240	87.1 39.5
5	x	4 DN100		53.00 1346	7.25 184	12.94 329	10.88 276	135.6 61.5
6 DN150	x	4 DN100		59.31 1506	14.50 368	20.63 524	11.25 286	198.3 89.9
		6 DN150		59.50 1511	10.25 260	16.38 416	11.25 286	186.1 84.4
8 DN200	x	4 DN100		75.94 1929	18.75 476	26.38 670	16.94 430	350.4 158.9
		6 DN150		75.94 1929	18.75 476	26.38 670	16.94 430	376.8 170.9
		8 DN200		76.00 1930	13.50 343	21.06 535	16.94 430	334.1 151.5
10 DN250	x	6 DN150		92.56 2351	22.56 573	31.13 791	17.69 449	644.3 292.2
		8 DN200		92.56 2351	22.56 573	31.13 791	17.69 449	585.9 265.8
12 DN300	x	8 DN200		108.87 2765	26.56 675	36.19 919	18.94 481	910.9 413.2

¹ Estimated weight using standard weight pipe.

5.0 COMPONENT PERFORMANCE

Balancing Valve Flow Characteristics

Size		Min Flow GPM LPM	Nominal Range of Flow GPM LPM	Max Flow GPM LPM
Nominal inches DN	Actual Outside Diameter inches mm			
3 DN80	3.500 88.9	1.5 5.7	31.0 – 130.0 117.0 – 493.0	410.0 1551.9
4 DN100	4.500 114.3	1.9 7.2	68.0 – 200.0 257.0 – 757.0	650.0 2460.3
5	5.563 141.3	4.2 15.9	90.0 – 320.0 341.0 – 1211.0	1020.0 3860.7
6 DN150	6.625 168.3	5.0 18.9	182.0 – 450.0 689.0 – 1703.0	1430.0 5214.6
8 DN200	8.625 219.1	30.0 113.6	367.0 – 820.0 1389.0 – 3104.0	2600.0 9841.0
10 DN250	10.750 273.0	70.0 265.0	540.0 – 1300.0 2044.0 – 4921.0	4040.0 15291.4
12 DN300	12.750 323.9	115.0 435.3	960.0 – 1500.0 3634.0 – 5678.0	4950.0 18735.8

5.1 COMPONENT PERFORMANCE

Check Valve Flow Characteristics

Cv/Kv values for flow of water at +60°F/+16°C at full open are shown below.

Formulas for Cv/Kv values:

$$\Delta P = \frac{Q^2}{C_v^2}$$

$$Q = C_v \times \sqrt{\Delta P}$$

Where:

Q = Flow (GPM)

ΔP = Pressure Drop (psi)

C_v = Flow Coefficient

$$\Delta P = \frac{Q^2}{K_v^2}$$

$$Q = K_v \times \sqrt{\Delta P}$$

Where:

Q = Flow (m³/hr)

ΔP = Pressure Drop (Bar)

K_v = Flow Coefficient

Size			Size		
Nominal	Actual Outside Diameter	(Full Open)	Nominal	Actual Outside Diameter	(Full Open)
inches DN	inches mm	C_v K_v	inches DN	inches mm	C_v K_v
3	3.500	315	8	8.625	1800
DN80	88.9	273	DN200	219.1	1557
4	4.500	390	10	10.750	3000
DN100	114.3	337	DN250	273.0	2595
5	5.563	700	12	12.750	4200
DN125	141.3	606	DN300	323.9	3633
6	6.625	1000			
DN150	168.3	865			

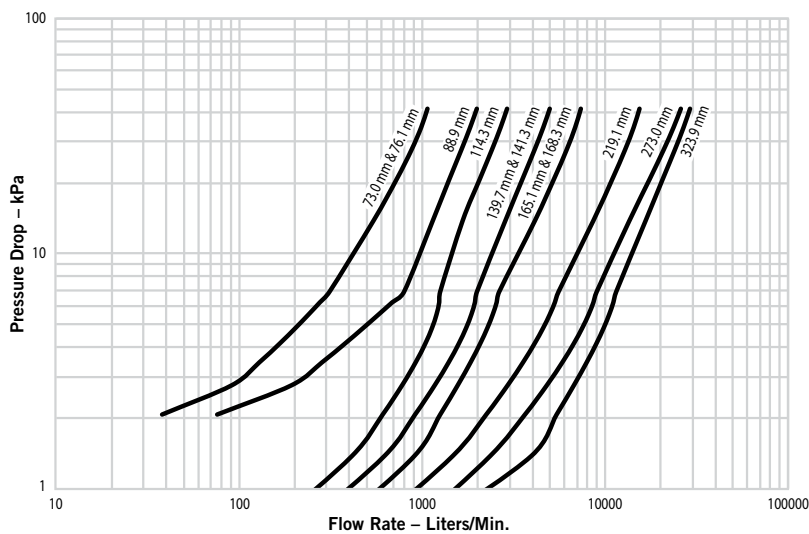
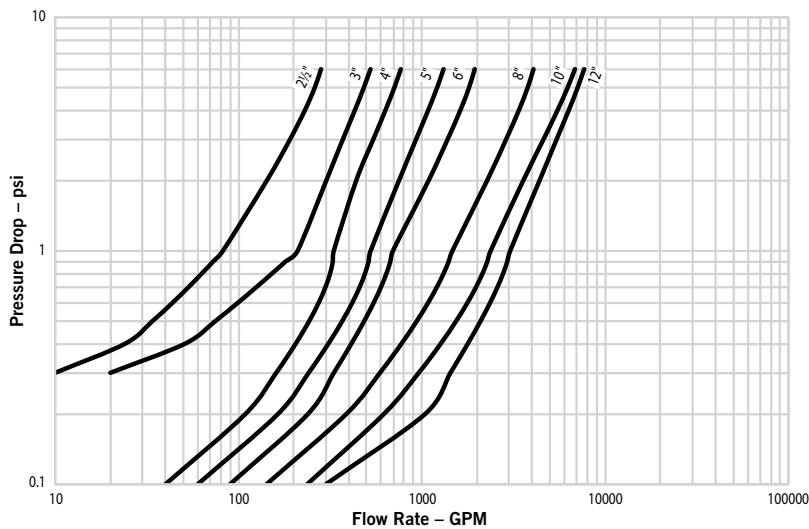

6.0 NOTIFICATIONS

WARNING



- Read and understand all instructions before attempting to install, remove, adjust, or maintain any Victaulic piping products.
- Depressurize and drain the piping system before attempting to install, remove, adjust, or maintain any Victaulic piping products.
- Wear safety glasses, hardhat, and foot protection.
- A Victaulic flexible coupling (not included) must also be installed in the piping above the Series 383/383G Discharge CBV Isolation Pump Drop when using a vertical configuration with no reduction in pipe size.

Failure to follow these instructions could result in death or serious personal injury and property damage.

7.0 REFERENCE MATERIALS

[05.01: Victaulic Seal Selection Guide](#)

[06.15: Victaulic Pressure Ratings and End Loads for Victaulic Couplings on Steel Pipe](#)

[07.13: Victaulic Base Support Elbows Nos. 100F, R100F, 100G and R100G](#)

[08.16: Victaulic Balancing Valves TA Series 786/787/788/789 and Series 78KH](#)

[26.01: Victaulic Design Data](#)

[26.04: Victaulic Vibration Couplings Vibration Attenuation Characteristics](#)

[29.01: Victaulic Terms and Conditions/Warranty](#)

[I-100: Victaulic Field Installation Handbook](#)

[I-177N: Victaulic Installation Instructions for QuickVic™ Flexible Coupling - Style 177N](#)

User Responsibility for Product Selection and Suitability

Each user bears final responsibility for making a determination as to the suitability of Victaulic products for a particular end-use application, in accordance with industry standards and project specifications, and the applicable building codes and related regulations as well as Victaulic performance, maintenance, safety, and warning instructions. Nothing in this or any other document, nor any verbal recommendation, advice, or opinion from any Victaulic employee, shall be deemed to alter, vary, supersede, or waive any provision of Victaulic Company's standard conditions of sale, installation guide, or this disclaimer.

Intellectual Property Rights

No statement contained herein concerning a possible or suggested use of any material, product, service, or design is intended, or should be construed, to grant any license under any patent or other intellectual property right of Victaulic or any of its subsidiaries or affiliates covering such use or design, or as a recommendation for the use of such material, product, service, or design in the infringement of any patent or other intellectual property right. The terms "Patented" or "Patent Pending" refer to design or utility patents or patent applications for articles and/or methods of use in the United States and/or other countries.

Note

This product shall be manufactured by Victaulic or to Victaulic specifications. All products to be installed in accordance with current Victaulic installation/assembly instructions. Victaulic reserves the right to change product specifications, designs and standard equipment without notice and without incurring obligations.

Installation

Reference should always be made to the Victaulic installation handbook or installation instructions of the product you are installing. Handbooks are included with each shipment of Victaulic products, providing complete installation and assembly data, and are available in PDF format on our website at www.victaulic.com.

Warranty

Refer to the Warranty section of the current Price List or contact Victaulic for details.

Trademarks

Victaulic and all other Victaulic marks are the trademarks or registered trademarks of Victaulic Company, and/or its affiliated entities, in the U.S. and/or other countries.