

Victaulic® Butterfly Valve

Series 250-S



17.69



1.0 PRODUCT DESCRIPTION

Available Sizes

- 2 – 8"/DN50 – DN200.

Pipe Material

- Stainless Steel Pipe.

End Preparation

- Victaulic Original Groove System (OGS).

Maximum Working Pressure

- Accommodates pressures ranging from full vacuum (29.9 in Hg/760 mm Hg) up to 250psi/1724kPa/17bar for S250-S4.
- Full working pressure for bi-directional, dead end services.

NOTE

- Before start up, the test pressure may be increased to 1.1 times the maximum working pressure with disc closed, and 1.5 times with the valve in the open position. This is for a one-time system test and must be performed at ambient conditions.

Operating Temperature

- Dependent on seat selection from section 3.0.

Application

- Use on systems where stainless steel piping is required; typical examples include potable water, technical cooling water, and HVAC, among others.

Actuation Options

- ISO 5211 mounting flange with ISO 5211 parallel square head drive.
- 10-position handle, padlockable.
- Gear operator.
- Accommodates 2"/50 mm of insulation.
- Chainwheel.

ALWAYS REFER TO ANY NOTIFICATIONS AT THE END OF THIS DOCUMENT REGARDING PRODUCT INSTALLATION, MAINTENANCE OR SUPPORT.



2.0 CERTIFICATION/LISTINGS



Valve construction and performance meet or exceed MSS-SP-67 requirements.

Compliant with Closure/Seat Leakage Rate A per EN 12266-1, EN 1074-1, EN 1074-2 and ISO 5208.

Meets requirements of ASME B16.34 Section 7 Pressure Testing and ASME B16.42 Section 8.1 Wall Thickness.

3.0 SPECIFICATIONS – MATERIAL

Body: Ductile iron conforming to ASTM A536, Grade 65-45-12.

End Faces: Stainless steel conforming to ASTM A351 Grade CF8/ASTM A473 UNS S30400.

Body Coating:

Standard: Blue coating.

Disc: Stainless steel conforming to ASTM A351 Grade CF8/ASTM A473 UNS S30400.

Seat:

Victaulic Fluoroelastomer blend: Fluoroelastomer blend (Double blue stripe color code). Temperature range -10°F to 180°F/-23°C to 82°C. Specifically formulated for compatibility with potable water systems. Optimized for improved resistance to chlorine, chloramine and other typical potable water disinfectants. UL Classified in accordance with ANSI/NSF 61 for cold +73°F/+23°C and hot +180°F/+82°C potable water service and ANSI/NSF 372.

NOT RECOMMENDED FOR PETROLEUM SERVICES OR STEAM SERVICES.

Stem: 416 stainless steel conforming to ASTM A582.

Optional: 17-4 PH stainless steel conforming to ASTM A564.

Bearings: Aluminum Bronze ASTM B505 C95400 or C95410.

Stem Retaining Ring: 316 stainless steel.

10 Position Handle:

Handle: Ductile iron conforming to ASTM A536, Grade 65-45-12, black coated. Plate: Carbon Steel, Zinc plated.

Gear Operator (with options below):

Handwheel.

Handwheel with chainwheel.

NOTE

- A padlockable valve refers to those valves which can be padlocked to lockout equipment for preventing inadvertent valve operation. When used in conjunction with an appropriate lockout/tagout system, multiple padlocks may be used. The valve may be padlocked either fully open or fully closed.

4.0 DIMENSIONS

Series 250-S4 Butterfly Valve - Bare Valve

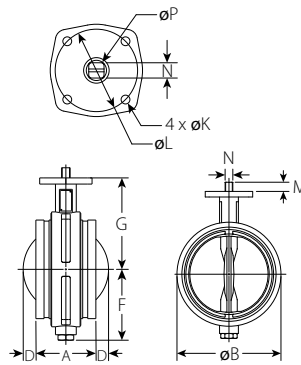

Size		Dimensions										Approx. Weight (Each) lb kg	ISO 5211 Flange Designation
Nominal inches DN	Actual Outside Diameter inches mm	A E to E inches mm	B inches mm	D inches mm	F inches mm	G inches mm	K inches mm	L inches mm	M inches mm	N (sq) inches mm	P inches mm		
2 DN50	2.375 60.3	3.19 81	3.50 88	-	2.38 60	4.13 103	0.34 8.5	2.76 70	0.70 18	0.35 9	0.47 12	4.1 1.9	F07
2 ½	2.875 73.0	3.81 97	4.13 105	-	2.63 65	4.25 108	0.34 8.5	2.76 70	0.70 18	0.35 9	0.47 12	6.1 2.8	F07
3 DN80	3.500 88.9	3.81 97	4.88 122	-	3.13 78	4.75 121	0.34 8.5	2.76 70	0.70 18	0.43 11	0.56 14	7.7 3.5	F07
4 DN100	4.500 114.3	4.56 116	5.75 146	-	3.63 91	5.25 134	0.34 8.5	2.76 70	0.70 18	0.43 11	0.56 14	11.0 5.0	F07
6 DN150	6.625 168.3	5.81 148	8.00 201	0.13 1	5.13 129	6.75 172	0.34 8.5	2.76 70	0.85 22	0.55 14	0.71 18	24.0 11.0	F07
8 DN200	8.625 219.1	5.25 133	10.13 256	1.25 31	6.25 158	8.00 204	0.43 10.9	4.02 102	0.89 23	0.74 19	0.98 25	39.0 17.5	F10

4.1 DIMENSIONS

Series 250-S4 Butterfly Valve - With Handle

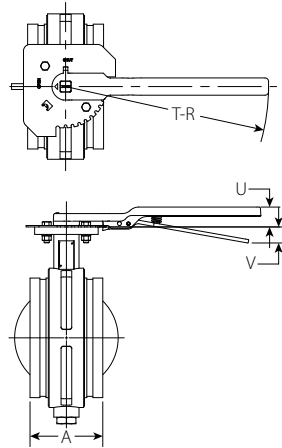

Size		Dimensions				Approx. Weight (Each)
Nominal inches DN	Actual Outside Diameter inches mm	A E to E inches mm	T-R inches mm	U inches mm	V inches mm	
2	2.375	3.19	8.50	1.50	0.50	6.1
DN50	60.3	81	216	37	12	2.8
2 ½	2.875	3.81	8.50	1.50	0.50	8.2
	73.0	97	216	37	12	3.7
3	3.500	3.81	8.50	1.50	0.50	9.7
DN80	88.9	97	216	37	12	4.4
4	4.500	4.56	8.50	1.50	0.50	13.0
DN100	114.3	116	216	37	12	5.9
6	6.625	5.81	12.00	1.50	1.00	27.0
DN150	168.3	148	305	37	25	12.0
8	8.625	5.25	14.13	1.50	1.25	43.0
DN200	219.1	133	357	37	30	19.5

4.2 DIMENSIONS

Series 250-S4 Butterfly Valve - With Gear Operator

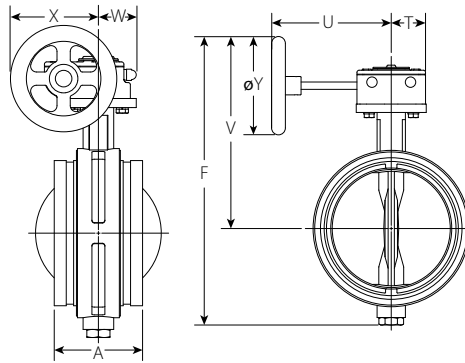

Size		Dimensions								Approx. Weight (Each)
Nominal	Actual Outside Diameter	A E to E	F	T	U	V	W	X	Y	
inches DN	inches mm	inches mm	inches mm	inches mm	inches mm	inches mm	inches mm	inches mm	inches mm	inches mm
2	2.375	3.19	9.50	1.75	5.25	7.13	2.00	3.75	4.00	7.1
DN50	60.3	81	240	43	133	180	49	93	100	3.2
2 ½	2.875	3.81	9.88	1.75	5.25	7.38	2.00	3.75	4.00	9.0
	73.0	97	250	43	133	185	49	93	100	4.1
3	3.500	3.81	10.88	1.75	5.25	7.88	2.00	3.75	4.00	11.0
DN80	88.9	97	277	43	133	198	49	93	100	5.0
4	4.500	4.56	11.88	1.75	5.25	8.38	2.00	3.75	4.00	14.0
DN100	114.3	116	301	43	133	211	49	93	100	6.4
6	6.625	5.81	15.50	2.25	7.38	10.50	2.25	4.63	5.00	29.0
DN150	168.3	148	393	57	185	264	58	117	127	13.0
8	8.625	5.25	19.25	2.25	7.88	13.13	2.25	6.00	6.38	43.0
DN200	219.1	133	489	57	198	332	58	151	162	19.5

4.3 DIMENSIONS

Accessories

Chainwheels

Chainwheels are mounted to the gear operator handwheels. Sprocket rim and guide arms are made of cast aluminum. Chain is galvanized steel weldless lock link chain.

Always specify length of chain required.

For insulation and locking device, contact Victaulic for details. Handwheel input shaft extensions are not for use with chainwheels.

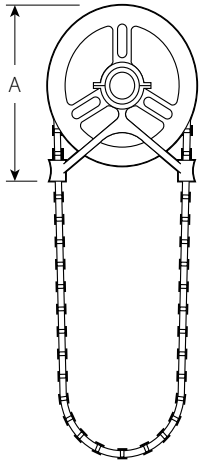

Chainwheel and Guide
with Safety Cable Kit

Size		Sprocket Size	Chain Trade Size	Dimensions		Approx. Weight (Each)
Nominal inches DN	Actual Outside Diameter inches mm	Sprocket Size	Chain Trade Size	Chainwheel Size (Diameter) inches mm	A inches mm	
2 – 4 DN50 – DN100	2.375 – 4.500 60.3 – 114.3	0	2	4.00 102	4.63 118	2.0 0.9
6 DN150	6.625 168.3	1	1/0	5.75 146	6.38 162	4.0 1.8
8 DN200	8.625 219.1	1½	1/0	7.50 190	7.75 197	5.0 2.3

5.0 PERFORMANCE

Series 250-S4 Butterfly Valve

C_v/K_v values for flow of water at +60°F/+16°C with various disc positions are shown in the table below.

Formulas for C_v/K_v values:

$$\Delta P = \frac{Q^2}{C_v^2}$$

$$Q = C_v \times \sqrt{\Delta P}$$

Where:

Q = Flow (GPM)
 ΔP = Pressure Drop (psi)
 C_v = Flow Coefficient

$$\Delta P = \frac{Q^2}{K_v^2}$$

$$Q = K_v \times \sqrt{\Delta P}$$

Where:

Q = Flow (m³/hr)
 ΔP = Pressure Drop (Bar)
 K_v = Flow Coefficient

Size		C _v /K _v Values
Nominal inches DN	Actual Outside Diameter inches mm	(Full Open) C _v K _v
2 DN50	2.375 60.3	190 164
2½	2.875 73.0	332 287
3 DN80	4.500 114.3	468 405
4 DN100	6.625 168.3	950 822
6 DN150	6.625 168.3	2187 1892
8 DN200	8.625 219.1	3650 3157

NOTE

- Victaulic recommends limiting the flow velocities for water service to 13.5 feet/second (4 meters/second).





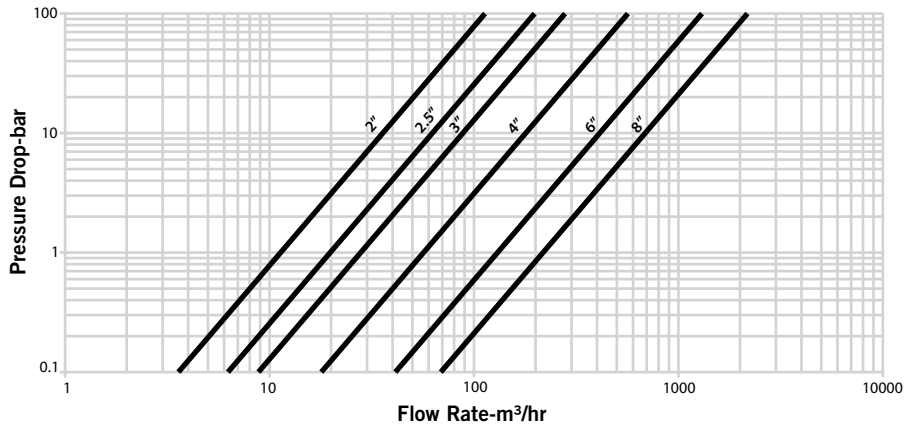
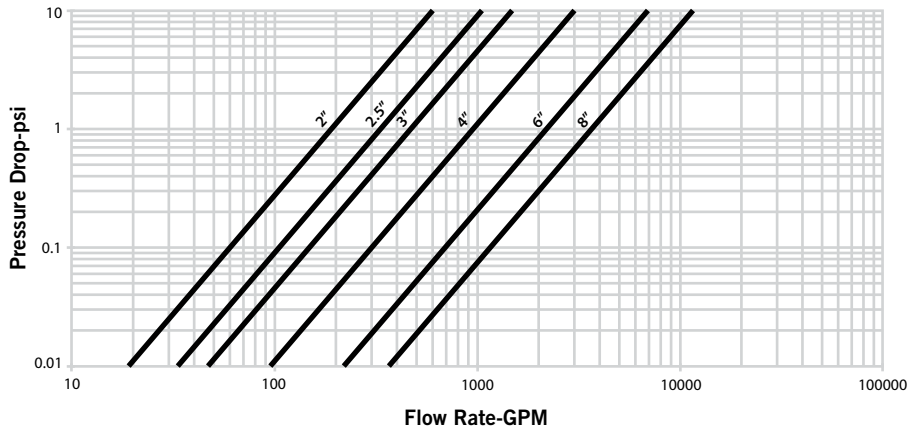

5.0 PERFORMANCE (CONTINUED)

Flow Characteristics Series 250-S4



5.0 PERFORMANCE (CONTINUED)

Series 250-S4 Butterfly Valve

Size		Flow Coefficients – Cv/Kv						
		Disc Position (Degrees Open)						
Nominal inches DN	Actual Outside Diameter inches mm	90	80	70	60	50	40	30
								
		Cv Kv	Cv Kv	Cv Kv	Cv Kv	Cv Kv	Cv Kv	Cv Kv
2 DN50	2.375	190	154	94	55	33	19	10
	60.3	164	133	81	48	29	16	9
2 ½	2.875	332	269	164	97	57	33	18
	73.0	287	233	142	84	49	29	16
3 DN80	3.500	468	379	232	136	80	46	25
	88.9	405	328	201	118	69	40	22
4 DN100	4.500	950	770	470	277	163	94	50
	114.3	822	666	407	240	141	81	43
6 DN150	6.625	2187	1772	1083	636	375	216	115
	168.3	1892	1533	937	550	324	187	99
8 DN200	8.625	3650	2958	1807	1062	625	360	193
	219.1	3157	2559	1563	919	541	311	167

5.1 PERFORMANCE

Torque Requirements

Series 250-S4 Butterfly Valve

Size		Torque – Inch Pounds/Newton Meters				
		Differential Pressure – psi/bar				
inches DN	inches mm	50/3 in/lb N/m	100/7 in/lb N/m	150/10 in/lb N/m	200/14 in/lb N/m	250/17 in/lb N/m
2 DN50	2.375 60.3	52 6	64 7	69 8	78 9	82 9
2 ½	2.875 73.0	70 8	76 9	81 9	90 10	94 11
3 DN80	3.500 88.9	104 12	117 13	136 15	162 18	179 20
4 DN100	4.500 114.3	125 14	155 18	186 21	227 26	253 29
6 DN150	6.625 168.3	270 31	343 39	428 48	504 57	573 65
8 DN200	8.625 219.1	517 58	691 78	893 101	1128 127	1241 140

Source:

These torque values were derived from test data with valves in water at ambient temperatures with Fluoroelastomer blend seals. For other material and service conditions, apply a suitable service factor.

Torque Factors:

All torque values are for normal conditions (i.e., the valve is operated at least once a quarter, disc corrosion is expected to be minor, the media is clean and nonabrasive, and the chemical effects upon the elastomer are minor).

Typical Fluid Torque Factors Commonly Used in the Industry:

Water: 1.0.

Material Torque Factors:

Fluoroelastomer blend = 1.0

Cycling Factor:

Valve torque will typically increase and actuator output decrease as the valve is cycled. A factor of 1.5 should be applied for when total valve cycles are expected to exceed 5,000.

5.1 PERFORMANCE (CONTINUED)

Actuation Factor:

A factor should be added to account for potential drift in the output of the actuator due to actuator performance, misalignment or external inputs (i.e., air or power supply). For this, a factor of up to 1.25 may be used.

Combining Torque Factors:







When multiple torque factors apply, they are combined by multiplying them. Example: For a Fluoroelastomer blend seal and a 5,000-cycle factor, the combined factor would be $1.0 \times (1.5) = 1.5$.

NOTES

- Under certain high flow conditions, the hydrodynamic torque can exceed the seating torque. Large butterfly valves are not recommended for use in a free discharge condition, such as filling an empty line with fluid at the full-rated pressure.
- Contact Victaulic for other services.

6.0 NOTIFICATIONS

WARNING 



- Read and understand all instructions before attempting to install, remove, adjust, or maintain any Victaulic piping products.
- Depressurize and drain the piping system before attempting to install, remove, adjust, or maintain any Victaulic piping products.
- Wear safety glasses, hardhat, and foot protection.

Failure to follow these instructions could result in death or serious personal injury and property damage.

7.0 REFERENCE MATERIALS

- [I-100: Victaulic Field Installation Handbook](#)
- [I-250: Installation and Maintenance Instructions - Series 250 Butterfly Valve](#)
- [I-ENDCAP: Victaulic End Cap Installation Safety Instructions](#)

User Responsibility for Product Selection and Suitability

Each user bears final responsibility for making a determination as to the suitability of Victaulic products for a particular end-use application, in accordance with industry standards and project specifications, and the applicable building codes and related regulations as well as Victaulic performance, maintenance, safety, and warning instructions. Nothing in this or any other document, nor any verbal recommendation, advice, or opinion from any Victaulic employee, shall be deemed to alter, vary, supersede, or waive any provision of Victaulic Company's standard conditions of sale, installation guide, or this disclaimer.

Intellectual Property Rights

No statement contained herein concerning a possible or suggested use of any material, product, service, or design is intended, or should be construed, to grant any license under any patent or other intellectual property right of Victaulic or any of its subsidiaries or affiliates covering such use or design, or as a recommendation for the use of such material, product, service, or design in the infringement of any patent or other intellectual property right. The terms "Patented" or "Patent Pending" refer to design or utility patents or patent applications for articles and/or methods of use in the United States and/or other countries.

Note

This product shall be manufactured by Victaulic or to Victaulic specifications. All products to be installed in accordance with current Victaulic installation/assembly instructions. Victaulic reserves the right to change product specifications, designs and standard equipment without notice and without incurring obligations.

Installation

Reference should always be made to the Victaulic installation handbook or installation instructions of the product you are installing. Handbooks are included with each shipment of Victaulic products, providing complete installation and assembly data, and are available in PDF format on our website at www.victaulic.com.

Warranty

Refer to the Warranty section of the current Price List or contact Victaulic for details.

Trademarks

Victaulic and all other Victaulic marks are the trademarks or registered trademarks of Victaulic Company, and/or its affiliated entities, in the U.S. and/or other countries.