

AGS Double Disc *Vic-Check* Series W715



AGS™

1.0 PRODUCT DESCRIPTION

Available Sizes

- 14 – 24"/DN350 – DN600

Pressure Class

- 232 psi/1600 kPa/16 Bar

Application

- Designed for drop tight sealing.
- Exclusively for use with pipe and Victaulic products which feature ends formed with the Victaulic AGS groove profile (see section 7.0 for Reference Materials).
- Operating temperature dependent upon gasket and/or seal selection – see Section 3.0.

2.0 CERTIFICATION/LISTINGS



Product designed and manufactured under the Victaulic Quality Management System, as certified by LPCB in accordance with ISO-9001:2008.

3.0 SPECIFICATIONS – MATERIAL

Body: Ductile iron conforming to ASTM A536 with painted black enamel finish

Disc: Stainless Steel – ASTM A351 Grade CF8

Seat: EPDM

EPDM. Temperature range +32°F to +180°F /0°C to +80°C. NOT RECOMMENDED FOR PETROLEUM SERVICES

Spring: Stainless Steel – 300 series

Shafts: Stainless Steel – 300 series

ALWAYS REFER TO ANY NOTIFICATIONS AT THE END OF THIS DOCUMENT REGARDING PRODUCT INSTALLATION, MAINTENANCE OR SUPPORT.

4.0 DIMENSIONS

Series W715

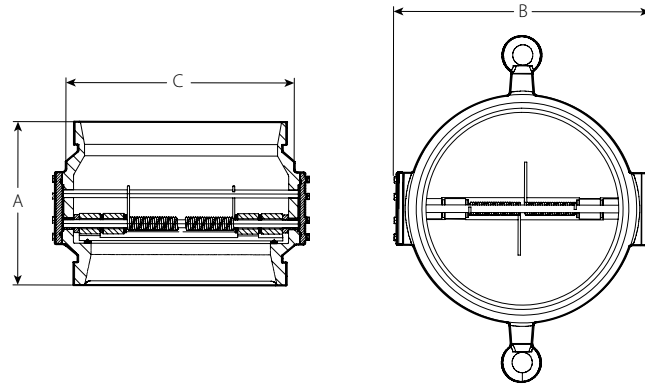

Size		Dimensions			Weight
Nominal inches DN	Actual Outside Diameter inches mm	A End to End inches mm	B inches mm	C inches mm	Approximate (Each) lb kg
14 DN350	14.000	10.75	17.00	15.13	106.9
	355.6	273	432	384	48.5
	14.843	10.75	17.00	15.13	134.5
	377.0	273	432	384	61.0
16 DN400	16.000	12.00	19.88	17.40	149.9
	406.4	305	505	442	68.0
	16.772	12.00	19.88	17.40	180.8
	426.0	305	505	442	82.0
18 DN450	18.000	14.25	21.88	19.38	231.5
	457.2	362	556	492	105.0
	18.898	14.25	21.88	19.38	269.0
	480.0	362	556	492	122.0
20 DN500	20.000	14.50	25.00	21.65	297.6
	508.0	368	635	550	135.0
	20.866	14.50	25.00	21.65	341.7
	530.0	368	635	550	155.0
24 DN600	24.000	15.50	28.88	25.38	454.2
	609.6	394	733	645	206.0
	24.803	15.50	28.88	25.38	498.2
	630.0	394	733	645	226.0

5.0 PERFORMANCE

The seat provides leak-free sealing under conditions as low as five feet of head

Formulas for C_v values

$$\Delta P = \frac{Q^2}{C_v^2}$$

$$Q = C_v \times \sqrt{\Delta P}$$

Where:

Q = Flow (GPM)

ΔP = Pressure Drop (psi)

C_v = Flow Coefficient

Size		Flow	
Nominal inches DN	Actual Outside Diameter inches mm	(Full Open)	
		C _v	K _v
14 DN350	14.000 355.6	6000	5190
	14.843 377.0	6000	5190
16 DN400	16.000 406.4	8300	7180
	16.772 426.0	8300	7180
18 DN450	18.000 457.2	10500	9080
	18.898 480.0	10500	9080
20 DN500	20.000 508.0	13800	11940
	20.866 530.0	13800	11940
24 DN600	24.000 609.6	20500	17730
	24.803 630.0	20500	17730

6.0 NOTIFICATIONS

WARNING



- Read and understand all instructions before attempting to install, remove, adjust, or maintain any Victaulic piping products.
- Depressurize and drain the piping system before attempting to install, remove, adjust, or maintain any Victaulic piping products.
- Wear safety glasses, hardhat, and foot protection.

Failure to follow these instructions could result in death or serious personal injury and property damage.

- **THIS PRODUCT SHALL BE USED ONLY WITH SHOULDERED-END PIPE, AS SPECIFIED WITHIN THIS SUBMITTAL.**

Failure to follow this instruction will cause joint failure, resulting in death or serious personal injury and property damage.

WARNING

- When grooving pipe for use with Series W715 AGS Double-Disc Vic-Check Valves, Victaulic roll grooving tools must be equipped with special Victaulic AGS (RW) roll sets made specifically for use with standard-weight pipe. Series W715 AGS Double-Disc Vic-Check Valves **MUST NOT** be installed on pipe that is prepared to original groove system (OGS) dimensions.

Failure to follow these instructions will cause improper assembly and joint failure, resulting in serious personal injury and property damage.

Caution

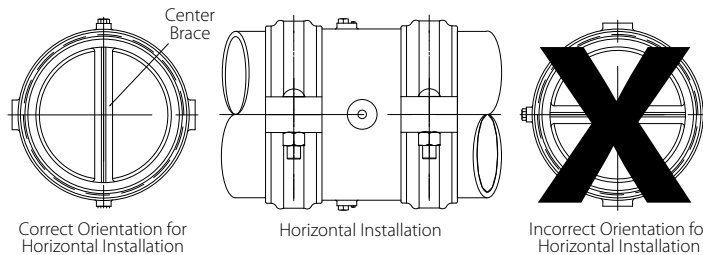

- For horizontal installations, the center brace inside the Series W715 AGS Double-Disc Vic-Check Valve must be in the vertical position, as shown above.

Failure to install the valve in the proper orientation will cause improper operation.

- When connecting a series W715 AGS Double-Disc Vic-Check Valve to a Series W761 Vic-300 AGS Butterfly Valve, a pipe spool is required between the two valves to prevent disc interference.
- When a Series W715 AGS Double-Disc Vic-Check Valve is placed near a Series W761 Vic-300 AGS Butterfly Valve, orient the center brace/disc shaft of the Series W715 at right angles to the butterfly valve stem.

Failure to follow these instructions will cause uneven and unstable flow through the Series W715, resulting in noise and reduced valve life.

7.0 REFERENCE MATERIALS

[25.09: AGS Roll Groove Data](#)

[26.01: Design Data](#)

[I-100: Field Installation Handbook](#)

User Responsibility for Product Selection and Suitability

Each user bears final responsibility for making a determination as to the suitability of Victaulic products for a particular end-use application, in accordance with industry standards and project specifications, and the applicable building codes and related regulations as well as Victaulic performance, maintenance, safety, and warning instructions. Nothing in this or any other document, nor any verbal recommendation, advice, or opinion from any Victaulic employee, shall be deemed to alter, vary, supersede, or waive any provision of Victaulic Company's standard conditions of sale, installation guide, or this disclaimer.

Intellectual Property Rights

No statement contained herein concerning a possible or suggested use of any material, product, service, or design is intended, or should be construed, to grant any license under any patent or other intellectual property right of Victaulic or any of its subsidiaries or affiliates covering such use or design, or as a recommendation for the use of such material, product, service, or design in the infringement of any patent or other intellectual property right. The terms "Patented" or "Patent Pending" refer to design or utility patents or patent applications for articles and/or methods of use in the United States and/or other countries.

Note

This product shall be manufactured by Victaulic or to Victaulic specifications. All products to be installed in accordance with current Victaulic installation/assembly instructions. Victaulic reserves the right to change product specifications, designs and standard equipment without notice and without incurring obligations.

Installation

Reference should always be made to the Victaulic installation handbook or installation instructions of the product you are installing. Handbooks are included with each shipment of Victaulic products, providing complete installation and assembly data, and are available in PDF format on our website at www.victaulic.com.

Warranty

Refer to the Warranty section of the current Price List or contact Victaulic for details.

Trademarks

Victaulic and all other Victaulic marks are the trademarks or registered trademarks of Victaulic Company, and/or its affiliated entities, in the U.S. and/or other countries.