

Victaulic Roll Grooving Tool

Model RG2910



1.0 PRODUCT DESCRIPTION

Grooving Capability:

- 1"/DN25

Application:

- Roll grooving tool designed to cold-form the IGS™ groove profile on Schedule 10 – 40 carbon steel pipe

Performance:

Tool Ratings — Maximum Pipe Size and Wall Thickness Capacity		Pipe Size inches DN
Model	Pipe Material	1 25
RG2910	Carbon steel	Sch. 10 – 40 2.8 – 3.6 mm

2.0 CERTIFICATION/LISTINGS

Manufactured by Victaulic Company

Compliant with the Essential Safety Requirements of 2006/42/EC - EU Machinery Directive

3.0 SPECIFICATIONS

Drive Requirements: This tool is compatible with the below power drive units:

- REMS™ Magnum 2
- Ridgid™ 300
- Ridgid 300 Compact
- Ridgid 535
- Ridgid 1215
- Rothenberger™ 50R

Power Requirements: Dependent on power drive operation

NOTES

- Ridgid™ is a trademark of Ridgid, Inc. Victaulic is not associated with Ridgid, Inc.
- REMS™ is a trademark of REMS, Inc. Victaulic is not associated with REMS, Inc.
- Rothenberger™ is a trademark of Rothenberger™, Inc. Victaulic is not associated with Rothenberger, Inc.

ALWAYS REFER TO ANY NOTIFICATIONS AT THE END OF THIS DOCUMENT REGARDING PRODUCT INSTALLATION, MAINTENANCE OR SUPPORT.

System No.		Location	
Submitted By		Date	

Spec Section		Paragraph	
Approved		Date	

4.0 ACCESSORIES/COMPONENTS

- One (1) RG2910 Roll Grooving Tool
- Three (3) Carriage Adapters
- Two (2) Operating and Maintenance Instructions Manuals
- One (1) Hex Key
- One (1) Groove Confirmation Cable

5.0 DIMENSIONS

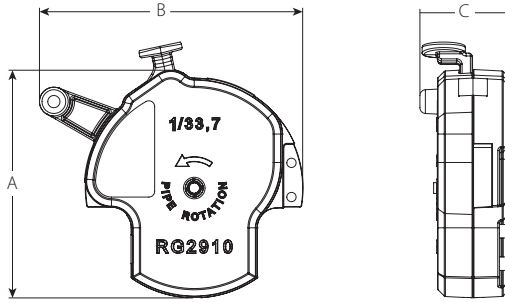

Dimensions			Weight
A Height inches mm	B Width inches mm	C Depth inches mm	Approximate (Each) lb kg
8.00 200	7.50 191	3.00 78	19 8.5

6.0 NOTIFICATIONS

WARNING



- Read and understand all instructions in the RG2910 Operating and Maintenance Manual.
- Wear safety glasses, hard hat, foot protection, and hearing protection when working around the tool.
- Failure to follow these instructions may cause improper product assembly and joint failure, resulting in serious personal injury and property damage.

Failure to follow all instructions and warnings could result in death or serious personal injury and property damage.

7.0 REFERENCE MATERIALS

[24.01: Pipe Preparation Tool Specifications](#)

[25.14: IGS™ Roll Groove System Specifications](#)

[TM-RG2910: Operating and Maintenance Instructions Manual](#)

User Responsibility for Product Selection and Suitability

Each user bears final responsibility for making a determination as to the suitability of Victaulic products for a particular end-use application, in accordance with industry standards and project specifications, as well as Victaulic performance, maintenance, safety, and warning instructions. Nothing in this or any other document, nor any verbal recommendation, advice, or opinion from any Victaulic employee, shall be deemed to alter, vary, supersede, or waive any provision of Victaulic Company's standard conditions of sale, installation guide, or this disclaimer.

Intellectual Property Rights

No statement contained herein concerning a possible or suggested use of any material, product, service, or design is intended, or should be construed, to grant any license under any patent or other intellectual property right of Victaulic or any of its subsidiaries or affiliates covering such use or design, or as a recommendation for the use of such material, product, service, or design in the infringement of any patent or other intellectual property right. The terms "Patented" or "Patent Pending" refer to design or utility patents or patent applications for articles and/or methods of use in the United States and/or other countries.

Note

This product shall be manufactured by Victaulic or to Victaulic specifications. All products to be installed in accordance with current Victaulic installation/assembly instructions. Victaulic reserves the right to change product specifications, designs and standard equipment without notice and without incurring obligations.

Installation

Reference should always be made to the Victaulic installation handbook or installation instructions of the product you are installing. Handbooks are included with each shipment of Victaulic products, providing complete installation and assembly data, and are available in PDF format on our website at www.victaulic.com.

Warranty

Refer to the Warranty section of the current Price List or contact Victaulic for details.

Trademarks

Victaulic and all other Victaulic marks are the trademarks or registered trademarks of Victaulic Company, and/or its affiliated entities, in the U.S. and/or other countries.