

Series 758 FireLock® Actuated System Valve

With Deluge Trim
Grooved X Grooved and Flanged X Grooved

PRODUCT DESCRIPTION



The Victaulic® Series 758 Actuated System Valve with Deluge Trim controls the water supply entry into the deluge system's piping and open sprinklers. The Series 758 Actuated Valve is a low differential, latched clapper valve that separates system water supplies from deluge pipe sprinkler systems. The positive latching mechanism uses the supply's water pressure from upstream (city side) of the main control valve to hold the clapper shut. When the water pressure in the piston is released, the latch retracts from the clapper, and the valve actuates. The low differential, unique latch, and actuator design of the valve allows it to be reset without removing the cover.

Victaulic Series 758 Actuated System Valves feature a high-strength, low-weight, ductile iron body with pneumatic, hydraulic, and electric actuation methods. The straight-through body design provides superior flow and low pressure drop. It offers simple access to all internal parts for easy maintenance. All internal parts are replaceable. The valve is painted inside and out to increase corrosion resistance.

Maintenance and service can be performed from the installed position. The rubber clapper seal is replaced easily without removing the clapper from the valve. The body is tapped for main drain and all available trim configurations.

The valve features significantly reduced trim pieces and a slim design for a reduced footprint, which saves space and decreases weight. The trim includes an alarm test valve, which allows testing of the alarm system without reducing the system's pressure. The valve is available with a separate trim package, or it can be pre-trimmed. The low differential design is not subject to water columns.

The valve allows the water to operate a water motor alarm and/or electric pressure alarms.

The 1½"-6" (40 - 150 mm) valve is rated to 300 psi (2065 kPa) and is tested hydrostatically to 600 psi (4135 kPa). The 8" (200 mm) valve is rated to 225 psi (1550 kPa) and is tested hydrostatically to 450 psi (3100 kPa). Air pressure to water pressure ratio is approximately 1 to 8. Standard grooved dimensions conform to ANSI/AWWA C606. Standard flanged dimensions conform to ANSI B16.5, Class 150.

The Victaulic Series 758 Actuated System Valve is available grooved X grooved (all sizes) or flanged X grooved (4 - 8"/100 - 200 mm).

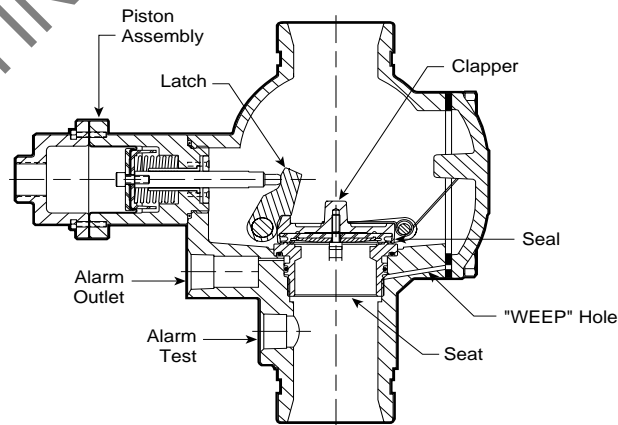

Exaggerated for Clarity

DIMENSIONS

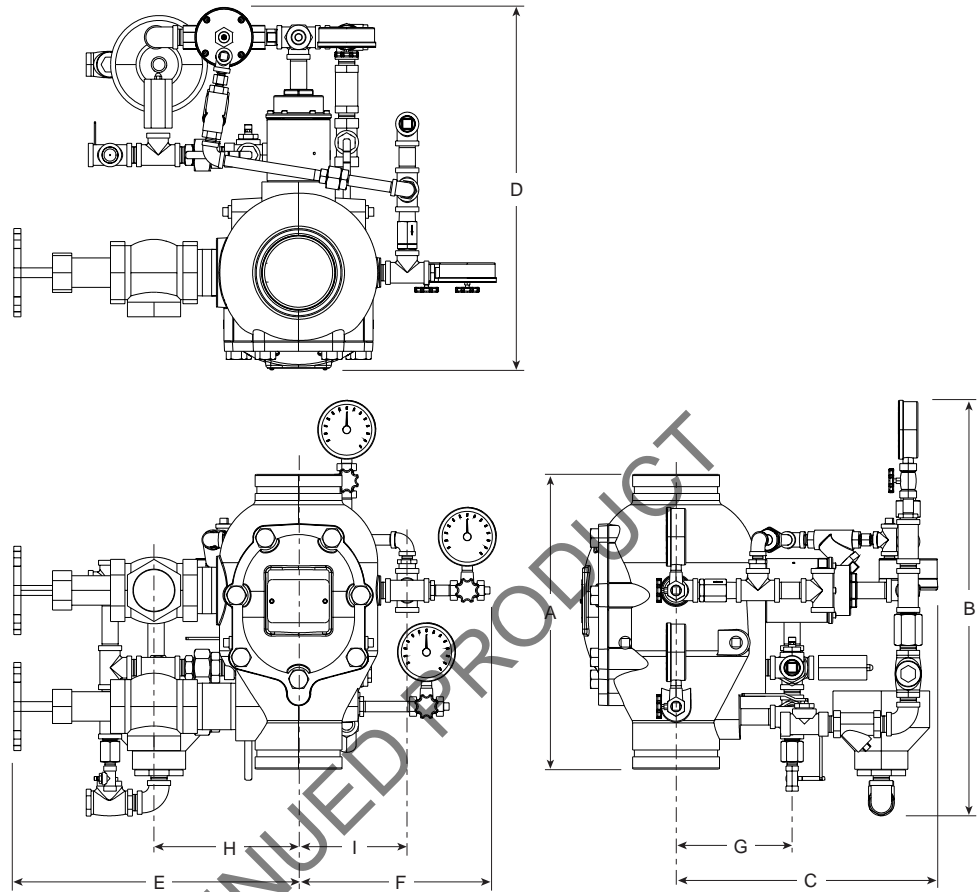

| VALVE SIZE | | Dimensions Inches/mm | | | | | | | | | | Aprx. Weight Each Lbs./kg | | | |
|---------------------------|-------------------------------------|-------------------------|--------------|--------------|--------------|--------------|--------------|--------------|-------------|-------------|---------------|------------------------------|-----------|---------------|---------------|
| Nominal Dia. In./mm | Actual Outside Dia. In./mm | A | B | C | D | E | F | G | H | I | Without Trim | | With Trim | | |
| | | | | | | | | | | | Flanged | Grooved | Flanged | Grooved | |
| GROOVED X GROOVED | | | | | | | | | | | | | | | |
| 1 1/2 40 | 1.900 48,3 | 9.00 228,60 | 21.00 533 | 13.00 330 | 18.00 457 | 13.00 330 | 10.00 254 | 7.00 178 | 4.00 102 | 4.00 102 | - | 16.7 7,6 | - | - | 43.0 19,5 |
| 2 50 | 2.375 60,3 | 9.00 228,60 | 21.00 533 | 13.00 330 | 18.00 457 | 13.00 330 | 10.00 254 | 7.00 178 | 4.00 102 | 4.00 102 | - | 17.0 7,7 | - | - | 43.0 19,5 |
| 2 1/2 65 | 2.875 73,0 | 12.61 320,29 | 21.00 533 | 14.00 356 | 20.00 508 | 15.50 394 | 11.50 292 | 7.50 191 | 5.00 127 | 5.00 127 | - | 41.2 18,7 | - | - | 65.0 29,5 |
| 76,1 mm | 3.000 76,1 | 12.61 320,29 | 21.00 533 | 14.00 356 | 20.00 508 | 15.50 394 | 11.50 292 | 7.50 191 | 5.00 127 | 5.00 127 | - | 41.2 18,7 | - | - | 65.0 29,5 |
| 3 80 | 3.500 88,9 | 12.61 320,29 | 21.00 533 | 14.00 356 | 20.00 508 | 15.50 394 | 11.50 292 | 7.50 191 | 5.00 127 | 5.00 127 | - | 42.1 19,1 | - | - | 65.0 29,5 |
| 4 100 | 4.500 114,3 | 15.03 381,76 | 20.00 508 | 15.00 381 | 21.00 533 | 14.00 356 | 12.00 305 | 8.00 203 | 9.00 229 | 6.00 152 | - | 55.0 24,9 | - | - | 95.0 43,1 |
| 6 150 | 6.625 168,3 | 16.00 406,40 | 21.10 536 | 16.00 406 | 22.00 559 | 14.00 356 | 12.00 305 | 8.50 216 | 7.00 178 | 7.00 178 | - | 73.0 33,1 | - | - | 115.0 52,2 |
| 165,1 mm | 6.500 165,1 | 16.00 406,40 | 21.10 536 | 16.00 406 | 22.00 559 | 14.00 356 | 12.00 305 | 8.50 216 | 7.00 178 | 7.00 178 | - | 73.0 33,1 | - | - | 115.0 52,2 |
| 8 200 | 8.625 219,1 | 17.50 444,50 | 18.00 457 | 16.00 406 | 23.00 584 | 16.00 406 | 12.00 305 | 14.00 356 | 9.50 241 | 7.00 178 | - | 142.0 64,4 | - | - | 182.0 82,6 |
| GROOVED X FLANGED | | | | | | | | | | | | | | | |
| 4 100 | 4.500 114,3 | 15.64 397,26 | 20.00 508 | 15.00 356 | 21.00 533 | 14.00 356 | 12.00 305 | 8.00 203 | 9.00 229 | 6.00 152 | 65.0 29,5 | - | - | 105.0 47,6 | - |
| 6 150 | 6.625 168,3 | 16.94 430,28 | 21.10 536 | 16.00 406 | 22.00 559 | 14.00 356 | 12.00 305 | 8.50 216 | 7.00 178 | 7.00 178 | 83.0 37,6 | - | - | 125.0 56,7 | - |
| 165,1 mm | 6.500 165,1 | 16.94 430,28 | 21.10 536 | 16.00 406 | 22.00 559 | 14.00 356 | 12.00 305 | 8.50 216 | 7.00 178 | 7.00 178 | 83.0 37,6 | - | - | 125.0 56,7 | - |
| 8 200 | 8.625 219,1 | 19.27 489,46 | 18.00 457 | 16.00 406 | 23.00 584 | 16.00 406 | 12.00 305 | 14.00 356 | 9.50 241 | 7.00 178 | 155.0 70,3 | - | - | 195.0 88,5 | - |

PERFORMANCE

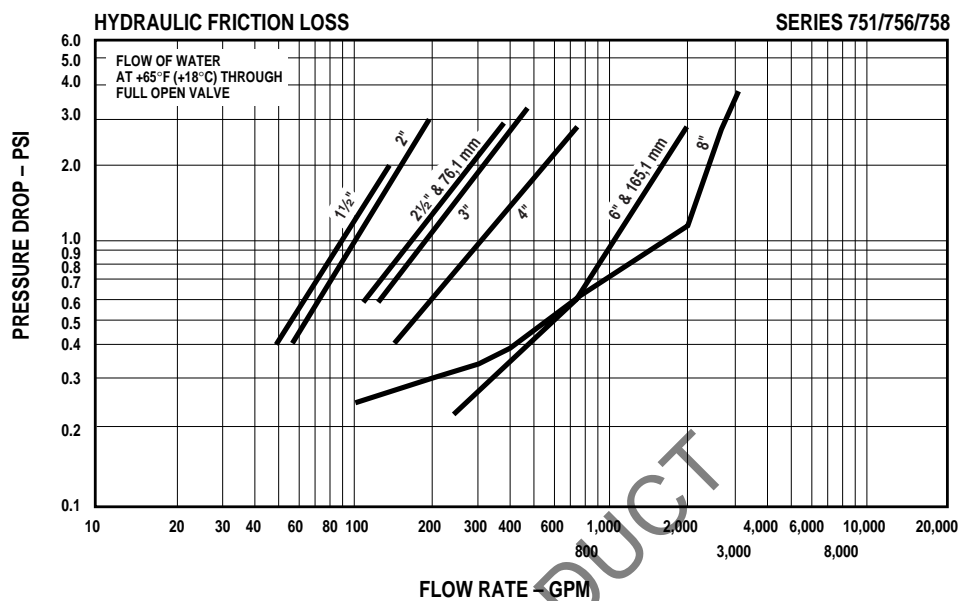

The chart below expresses the frictional resistance of Victaulic Series 758 Actuated System Valves in equivalent feet of straight pipe.

FRICTIONAL RESISTANCE

| Nominal Size Inches/ Actual mm | Equivalent Length of Pipe Feet | Nominal Size Inches/ Actual mm | Equivalent Length of Pipe Feet |
|--------------------------------------|-----------------------------------|--------------------------------------|-----------------------------------|
| 1 1/2 | 3 | 4 | 21 |
| 2 | 9 | 6 | 22 |
| 2 1/2 | 8 | 165,1 mm | 22 |
| 76,1 mm | 8 | 8 | 50 |
| 3 | 17 | | |

MATERIAL SPECIFICATIONS

Body: Ductile iron conforming to ASTM A-395, grade 65-45-15, and ASTM A-536, grade 65-45-12

Clapper: Aluminum bronze UNS-C95500 or UNS-C36000

Latch and Piston: Aluminum bronze UNS-C95500 or UNS-C36000

Clapper Seal: EPDM, ASTM D2000

Seat O-rings: Nitrile

Springs: Stainless steel (300 Series)

Shafts: Stainless 17-4

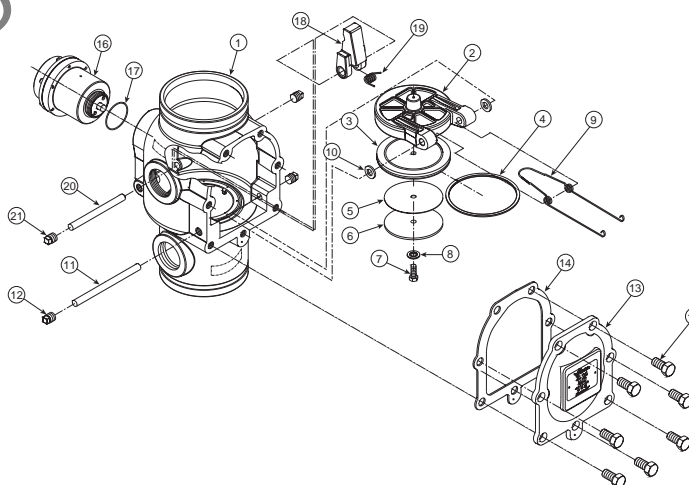

BILL OF MATERIALS

| | | |
|-----------------------|--|--|
| 1 Valve Body | 8 Bolt Seal | 15 Cover Plate Bolts (Qty. 7) |
| 2 Clapper | 9 Clapper Spring | 16 Piston |
| 3 Clapper Seal | 10 Spacers (Qty. 2) | 17 Piston O-ring |
| 4 Seal Ring | 11 Clapper Shaft | 18 Latch |
| 5 Seal Washer | 12 Clapper Shaft Retaining Plug (Qty. 2) | 19 Latch Spring |
| 6 Seal Retaining Ring | 13 Cover Plate | 20 Latch Shaft |
| 7 Seal Assembly Bolt | 14 Cover Plate Gasket | 21 Latch Shaft Retaining Plug (Qty. 2) |

TRIM PACKAGES

Trim packages available:

- 1 Trim for the deluge system installed in a pneumatic release system.
- 2 Trim for the deluge system installed in a hydraulic release system.
- 3 Trim for the deluge system installed in an electric release system.

Trim packages include:

- 1 All required pipe and fittings.
- 2 All standard trim accessories.
- 3 All required gauges.

Optional trim with black pipe for use with foam systems

Optional accessories:

- **Series 746 Accelerator** - The accelerator can be used on pneumatic release systems in order to speed the system's response time. Request 10.45 for submittal.
- **Series 753-A Dry Actuator** - The Series 753-A Dry Actuator maintains the water in the piston, controlled by the system air pressure, in pneumatic actuation systems. Request 10.36 for submittal.
- **Series 753-E Solenoid Valve** - The Series 753-E is designed for use with Series 758 Preaction and Deluge devices that use electric actuation.
- **Series 760 Water Motor Alarm** - The Series 758 deluge trim is designed to activate a mechanical water motor alarm when a sustained flow of water (such as an open sprinkler) causes the deluge clapper to lift from its seat. Request 10.38 for submittal.
- **Alarm pressure switch** - The Series 758 valve is designed to allow the installation of pressure switches to activate electric alarms and control panels when a sustained flow of water (such as an open sprinkler) causes the clapper to lift from its seat.
- **Air Supply System** - The air supply system contains all components for establishing and maintaining air in a pneumatic deluge system. Included in the air supply system is the compressor, low pressure alarms, ball valves, and required trim.
- **Air Compressor**
- **Air Dryer**
- **Air Maintenance Device**
- **Alarm Panels**
- **Solenoid Actuator**

AIR MAINTENANCE TRIM

RECOMMENDED AIR PRESSURES FOR SERIES 756 DRY VALVES WITH SERIES 753-A DRY ACTUATORS AND/OR SERIES 746 DRY ACCELERATORS

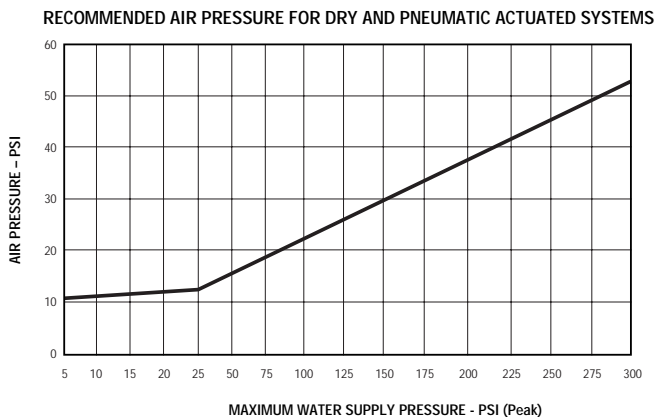

COMPRESSOR REQUIREMENTS

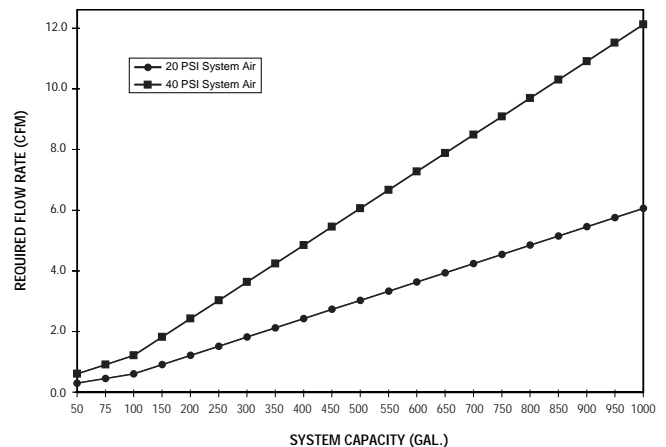

AIR MAINTENANCE TRIM

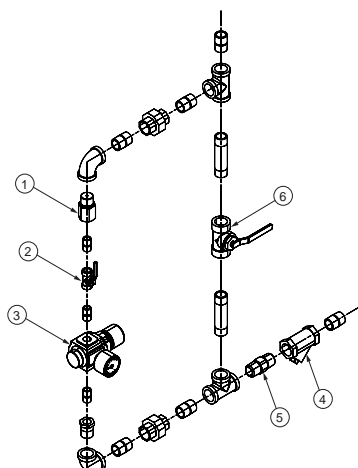

| Item | Description |
|------|--|
| 1 | 1/16-inch Restrictor |
| 2 | Slow Fill Ball Valve |
| 3 | Air Regulator |
| 4 | Strainer (100 Mesh) |
| 5 | Spring-Loaded, Soft-Seated Check Valve |
| 6 | Fast Fill Ball Valve |

NOTES:

- 1 The Victaulic air regulator is a relief-type design. Any pressure in the system that is above the set point of the regulator will be released. Therefore, charging the regulator above the set point could cause premature operation of a valve installed with a Series 746 Dry Accelerator.
- 2 The recommended air pressures, shown in the chart to the left, apply to dry valves that use a Series 753-A Dry Actuator.
- 3 For base or riser-mounted compressors, the recommended air pressures are the "on" or "low" pressure settings for the compressor.
- 4 For tank-mounted compressors, the recommended air pressures are the set point for the air regulator. The "on" pressure of the compressor should be at least 5 psi (34 kPa) above the set point of the regulator.
- 5 These pressures involve an 8-to-1 water-to-air ratio, plus a 10-pound safety factor.

EXAMPLE: For a system with an underground pressure of 80 psi (552 kPa):

Per the chart, the pressure should be set at 20. In addition, this pressure could be calculated by dividing the system's maximum water pressure by 8 and then adding 10 psi (69 kPa).

Proper Air Supplies for Series 756 Dry Valves Used with Series 753-A Dry Actuators Only:

- 1 When a riser or base-mounted air compressor supplies air to a system using a Series 753-A Dry Actuator, it is not necessary to use the air maintenance trim assembly with an air regulator. In this case, the airline of the compressor connects to the trim at the fitting where the air maintenance trim is normally installed.
- 2 Due to the large on/off differential available for pressure switches that control base-mounted compressors, adjust the compressor's pressure switch so that the "ON" contact is at the recommended air supply for the valve.

Proper Air Supplies for Series 756 Dry Valves Used with Series 753-A Dry Actuators and Series 746 Dry Accelerators:

- 1 When a Series 746 Dry Accelerator is used with the Series 753-A Dry Actuator, the air maintenance trim assembly MUST be used with the air regulator.
- 2 In the event that a compressor becomes inoperative, a properly sized tank-mounted air compressor provides the greatest protection for systems that use a Series 746 Dry Accelerator. In this situation, air can be supplied continuously to the sprinkler system for an extended time period.

WET PILOT LINE CHARTS

Heights are based on 1/2" schedule 40 pipe and a 1/2" sprinkler.

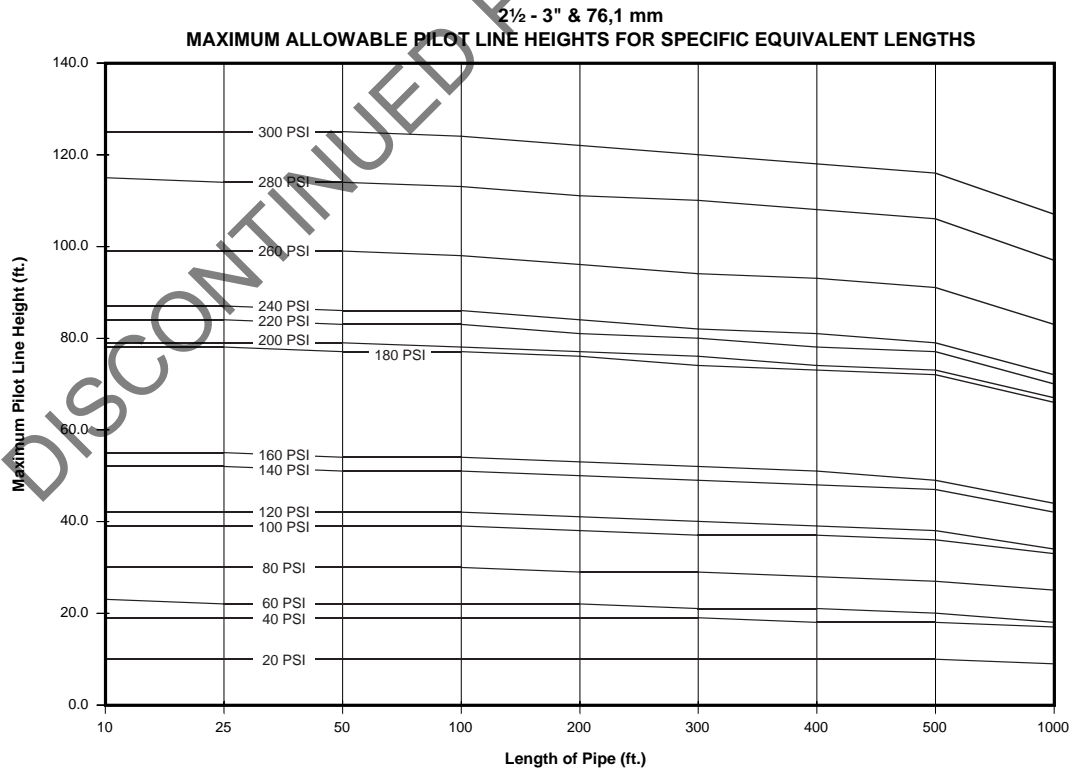
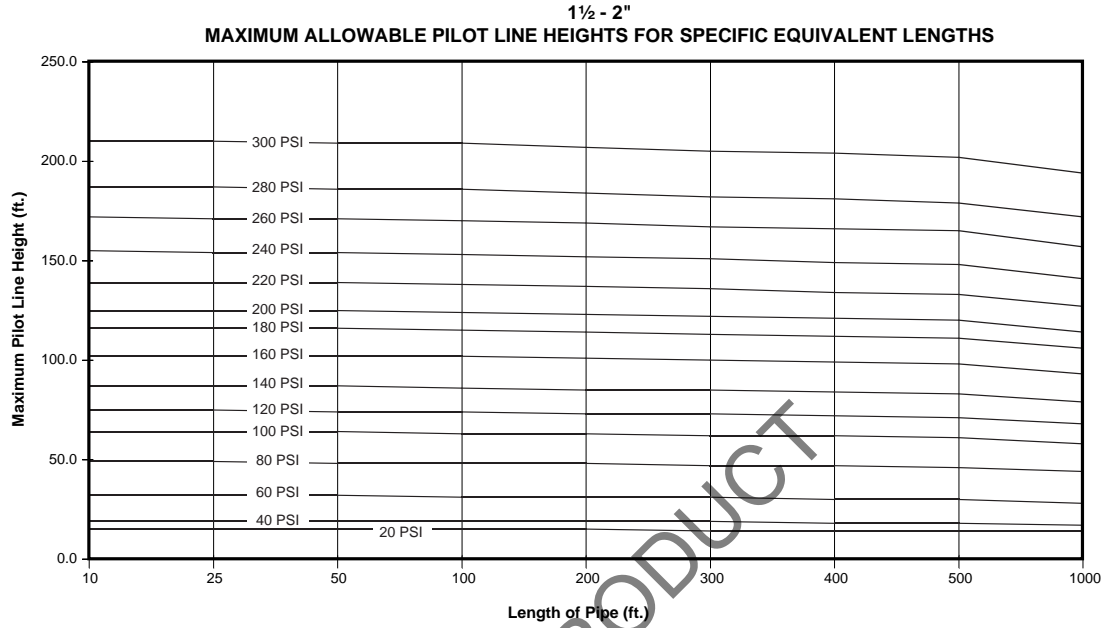

WET PILOT LINE CHARTS

Heights are based on 1/2" schedule 40 pipe and a 1/2" sprinkler.

4"

MAXIMUM ALLOWABLE PILOT LINE HEIGHTS FOR SPECIFIC EQUIVALENT LENGTHS

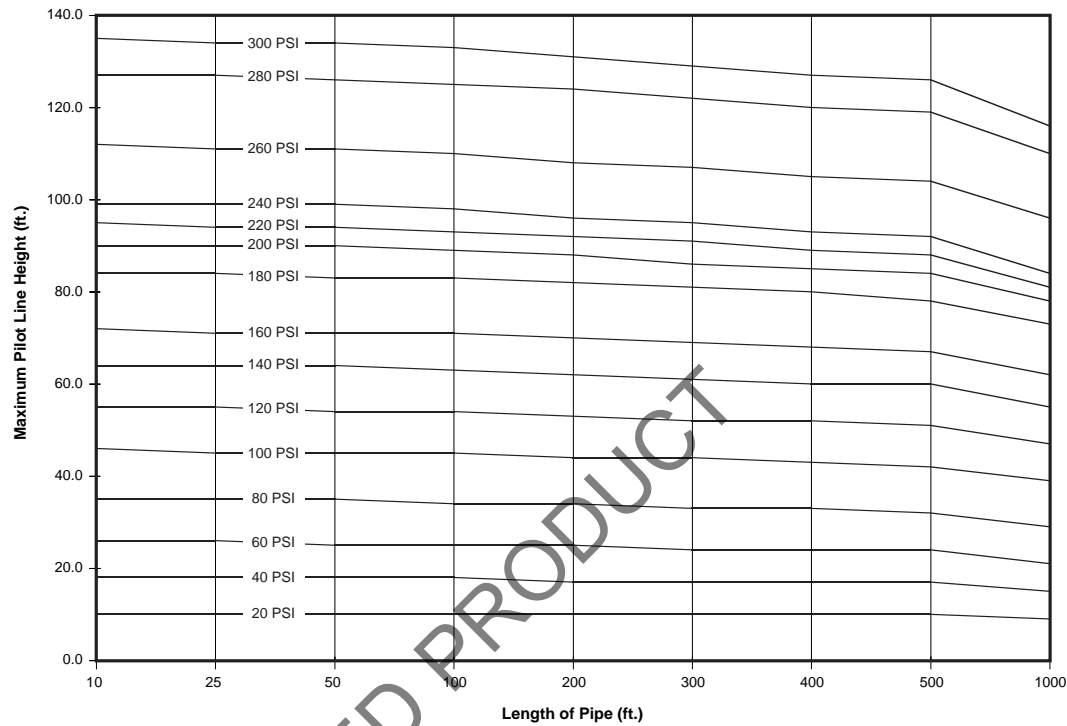

6" & 165,1 mm

MAXIMUM ALLOWABLE PILOT LINE HEIGHTS FOR SPECIFIC EQUIVALENT LENGTHS

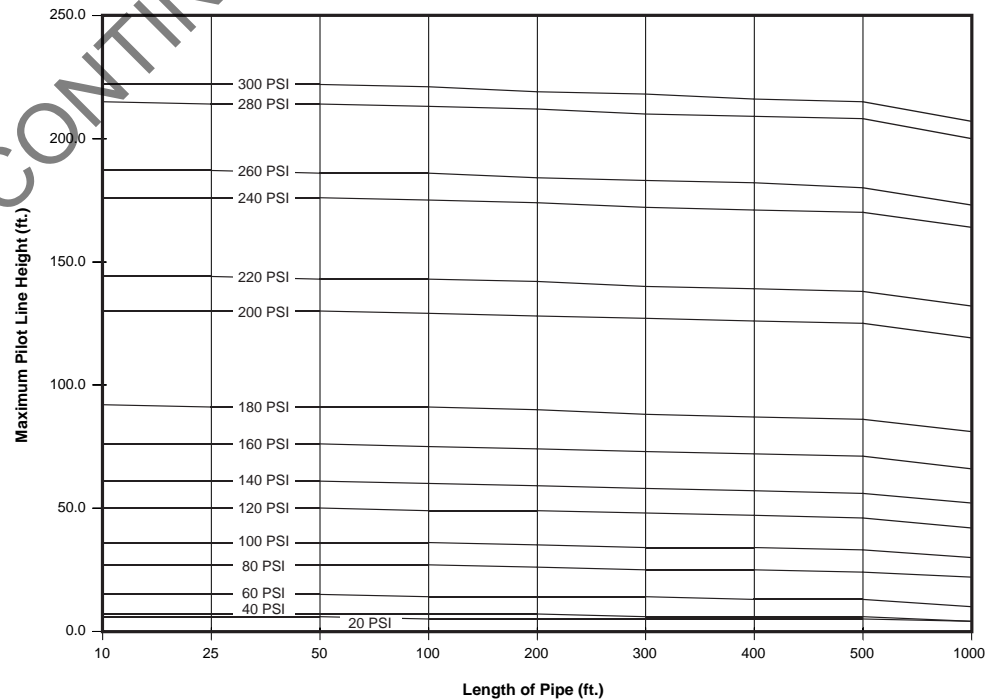

WET PILOT LINE CHARTS

Heights are based on 1/2" schedule 40 pipe and a 1/2" sprinkler.

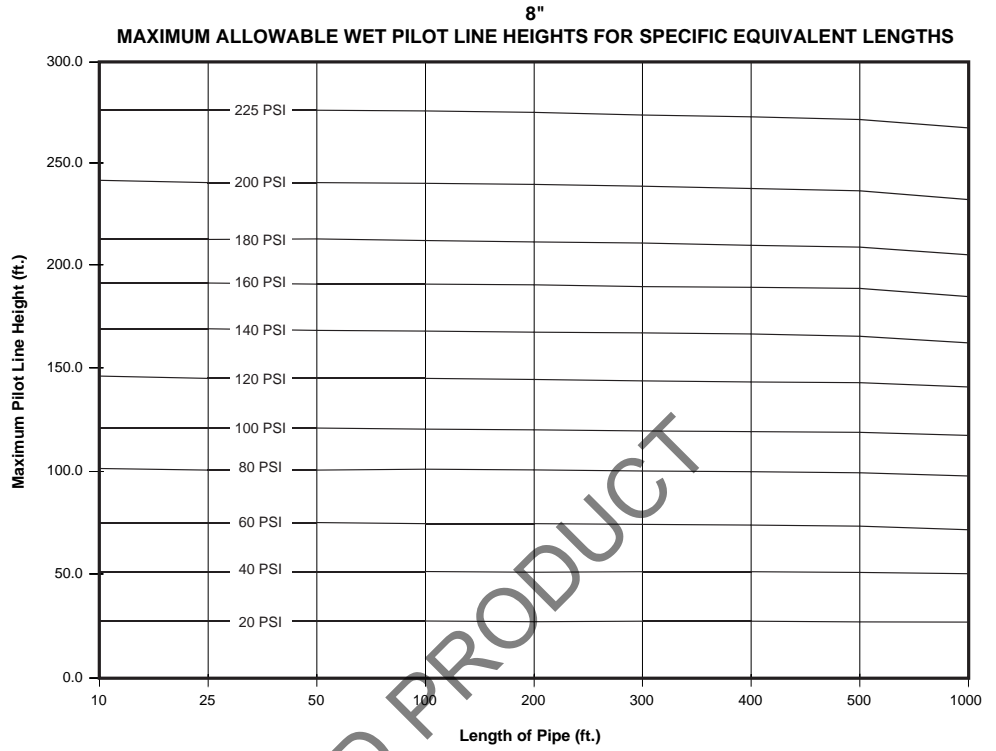

DISCONTINUED PRODUCT

TRIM

**Series 758 Automated Valve
with Pneumatic Release (Dry Pilot) Deluge Trim
(Pressure Switch, Dry Actuator, Accelerator/Anti-Flood Device, and Air Maintenance Trim OPTIONAL)**

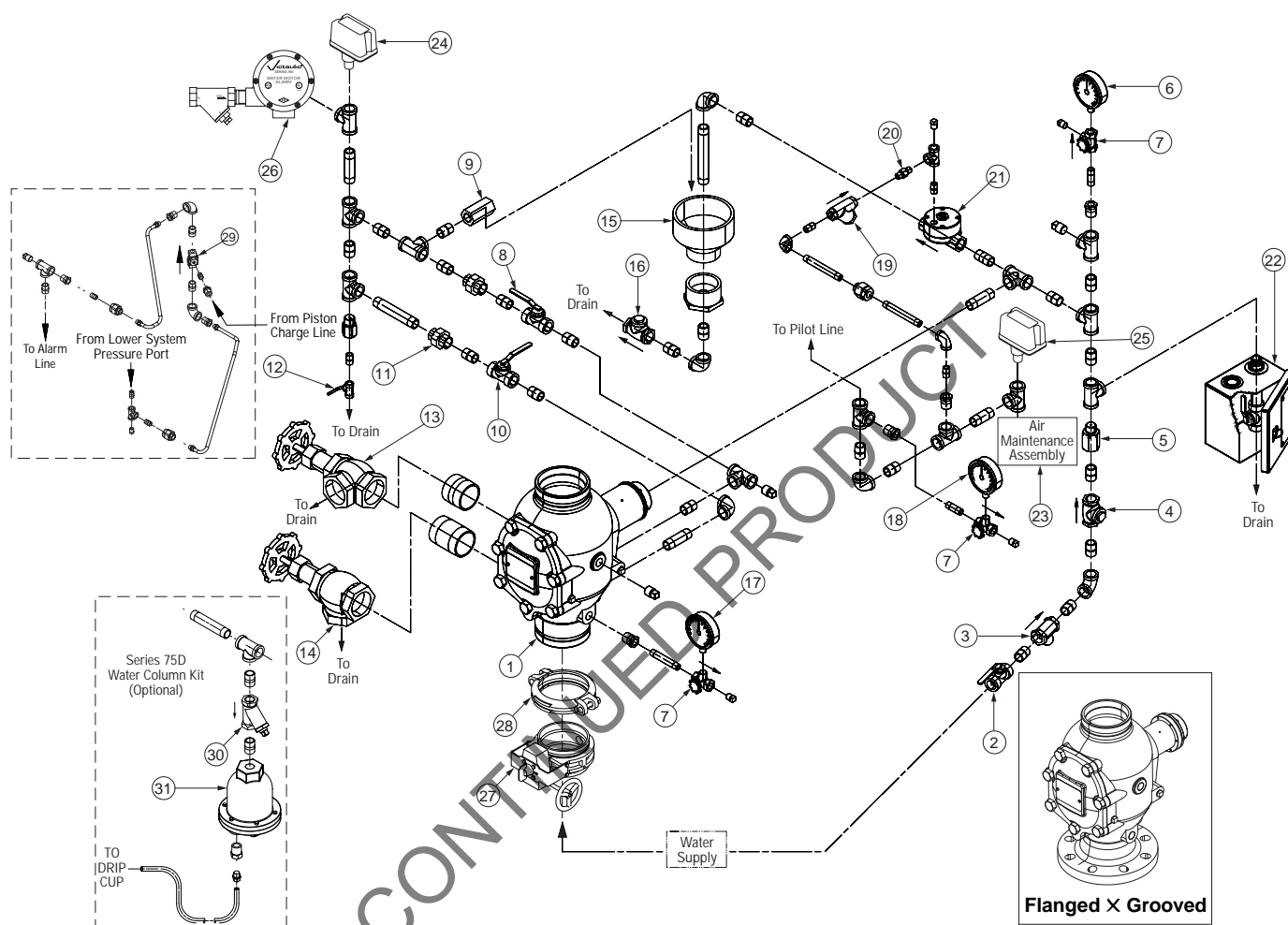

BILL OF MATERIALS

- | | |
|---|--|
| 1 Series 758 FireLock Actuated Check Valve with dry pilot deluge trim | 16 Drain Check Valve |
| 2 Piston Charge Line Ball Valve (NO) | 17 Water Supply Pressure Gauge (0-300 psi) |
| 3 Piston Charge Line Strainer (100 Mesh) | 18 Pilot Line Gauge Valve (0-80 psi with retard) |
| 4 Piston Charge Line Check Valve | 19 Air Line Strainer (100 Mesh) |
| 5 Piston Charge Line Restrictor (1/16") | 20 Air Line Restrictor (1/16") |
| 6 Piston Charge Line Pressure Gauge (0-300 psi) | 21 Series 753A Dry Actuator |
| 7 Gauge Valve | 22 Series 755 Manual Pull Station |
| 8 Alarm Line Ball Valve (NO) | 23 Series 757 Air Maintenance Device (Optional) |
| 9 Series 729 Drip Check Valve | 24 EPS-10 Alarm Pressure Switch (Optional) |
| 10 Alarm Test Line Ball Valve (NC) | 25 EPS-40 Supv. Switch (Optional) |
| 11 Alarm Line Drain Restrictor (1/16") | 26 Series 760 Water Motor Alarm (Optional) |
| 12 Alarm Line Drain Ball Valve (NC) | 27 Series 705W Control Valve with Tap (Optional) |
| 13 Main System Drain Valve | 28 Style 005 FireLock® Rigid Coupling (Optional) |
| 14 Main Drain Valve - Flow Test | 29 Series 75B Supplemental Alarm Device (Optional) |
| 15 Drip Cup | 30 Strainer (100 Mesh) |
| | 31 Series 75D Water Column Kit |

TRIM

Series 758 Automated Valve with Hydraulic Release (Wet Pilot) Deluge Trim (Pressure Switch OPTIONAL)

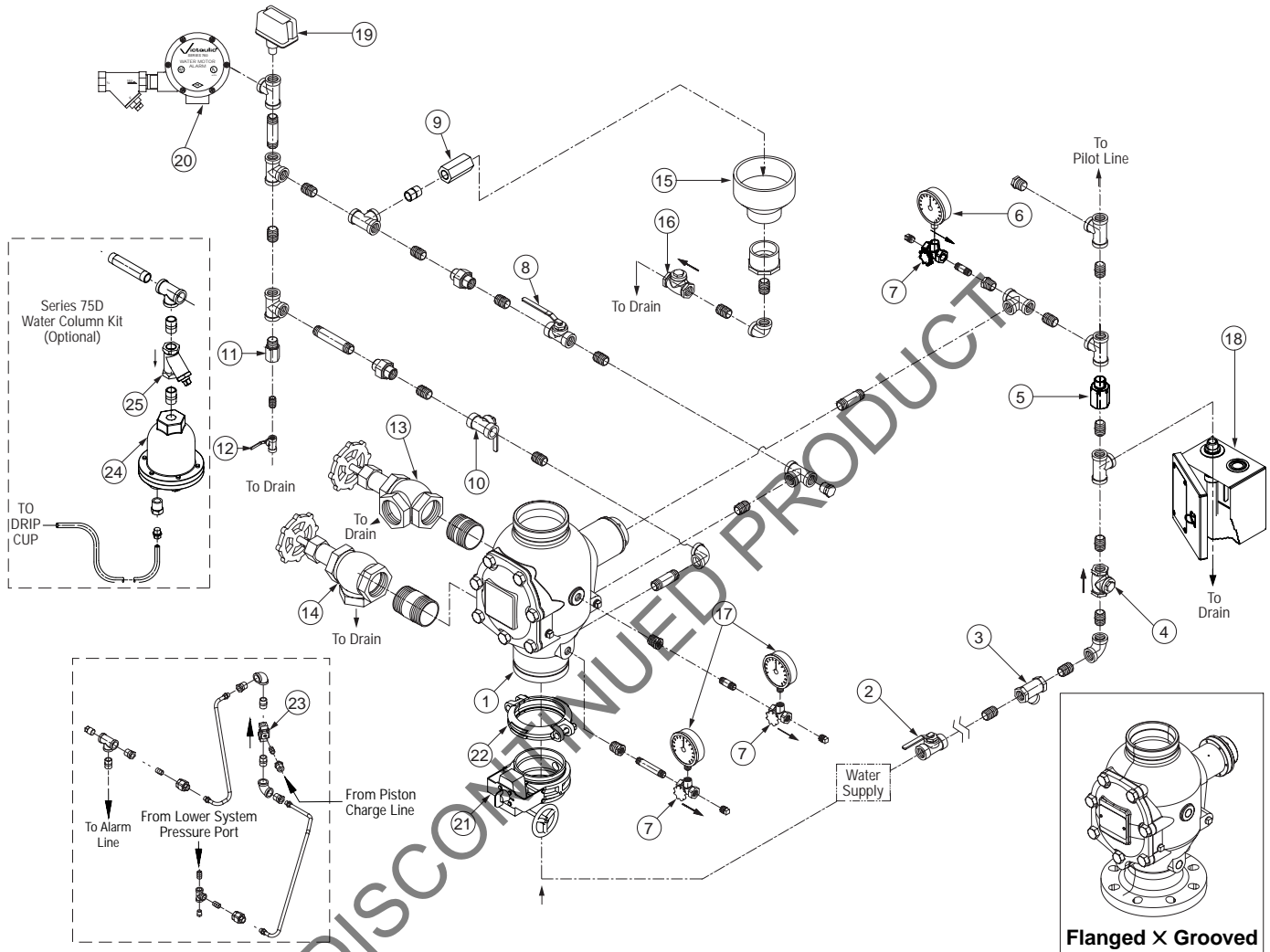

BILL OF MATERIALS

- | | |
|---|--|
| 1 Series 758 FireLock Actuated Check Valve with wet pilot deluge trim | 13 Main System Drain Valve |
| 2 Piston Charge Line Ball Valve (NO) | 14 Main Drain Valve - Flow Test |
| 3 Piston Charge Line Strainer (100 Mesh) | 15 Drip Cup |
| 4 Piston Charge Line Check Valve | 16 Drain Check Valve |
| 5 Piston Charge Line Restrictor (1/16") | 17 Water Supply Pressure Gauge (0-300 psi) |
| 6 Piston Charge Line Pressure Gauge (0-300 psi) | 18 Series 755 Manual Pull Station |
| 7 Gauge Valve | 19 EPS-10 Alarm Pressure Switch (Optional) |
| 8 Alarm Line Ball Valve (NO) | 20 Series 760 Water Motor Alarm (Optional) |
| 9 Series 729 Drip Check Valve | 21 Series 705W Butterfly Valve (Optional) |
| 10 Alarm Test Line Ball Valve (NC) | 22 Style 005 FireLock® Coupling (Optional) |
| 11 Alarm Line Drain Restrictor (1/16") | 23 Series 75B Supplemental Alarm Device (Optional) |
| 12 Alarm Line Drain Ball Valve (NC) | 24 Series 75D Water Column Kit |
| | 25 Strainer (100 Mesh) |

TRIM

**Series 758 Automated Valve
with Electric Release Deluge Trim
(Pressure Switch and Solenoid Actuator OPTIONAL)**

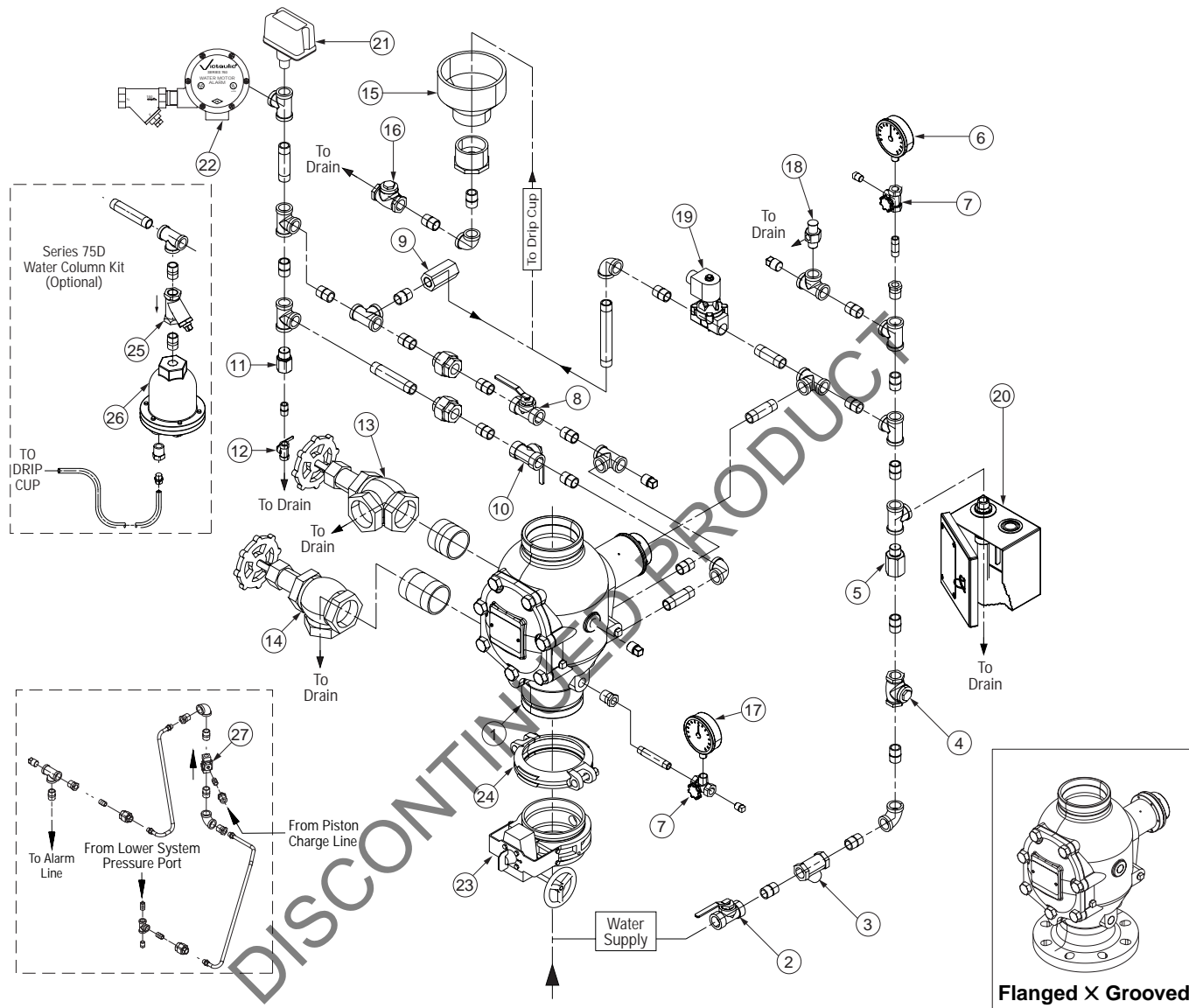

BILL OF MATERIALS

- | | |
|--|--|
| 1 Series 758 FireLock Actuated Check Valve with electric deluge trim | 14 Main Drain Valve - Flow Test |
| 2 Piston Charge Line Ball Valve (NO) | 15 Drip Cup |
| 3 Piston Charge Line Strainer (100 Mesh) | 16 Drain Check Valve |
| 4 Piston Charge Line Check Valve | 17 Water Supply Pressure Gauge (0-300 psi) |
| 5 Piston Charge Line Restrictor (1/16") | 18 Series 749 AutoDrain |
| 6 Piston Charge Line Pressure Gauge (0-300 psi) | 19 Electric Solenoid Valve |
| 7 Gauge Valve | 20 Series 755 Manual Pull Station |
| 8 Alarm Line Ball Valve (NO) | 21 EPS-10 Alarm Pressure Switch (Optional) |
| 9 Series 729 Drip Check Valve | 22 Series 760 Water Motor Alarm |
| 10 Alarm Test Line Ball Valve (NC) | 23 Series 705W Butterfly Valve (Optional) |
| 11 Alarm Line Drain Restrictor (1/16") | 24 Style 005 FireLock® Rigid Coupling (Optional) |
| 12 Alarm Line Drain Ball Valve (NC) | 25 Strainer (100 Mesh) |
| 13 Main System Drain Valve | 26 Series 75D Water Column Kit |
| | 27 Series 75B Supplemental Alarm Device (Optional) |

OPERATION

The Victaulic Deluge System utilizes the Series 758 Actuated Valve to control the water supply's entry into the deluge system's piping and open sprinklers. The Series 758 Actuated Valve is constructed with a clapper, which has a replaceable rubber face. The clapper makes contact with the valve seat ring, which has access holes to the intermediate chamber of the valve. The clapper is contacted by the latch, which is contacted by the piston rod. In the closed position, water supply pressure from upstream of the water supply control valve is maintained in the valve piston, which holds the clapper in the closed position. The water is maintained in the piston by one of the system release mechanisms (pneumatic, hydraulic or electric). Upon detection of an actuating event of the deluge system, such as an actuated pilot sprinkler or heat detection, the water supply pressure in the piston is released. This causes the piston rod to retract, and it permits the clapper to pivot freely, thus allowing water into the deluge system. Water will flow from all open sprinklers in the piping. Also, water enters the intermediate chamber of the valve through the holes in the seat ring. The water flows from the intermediate chamber to the alarm line, which activates the system's alarms. These alarms continue to sound until the flow of water is stopped.

Important Note: If air pressure in a pneumatic system is lost, a low air alarm (optional) will activate. If air pressure is not restored, the valve will actuate. If a pilot sprinkler in either a pneumatic or hydraulic system is damaged, the valve will actuate and water will flow from all open sprinklers in the deluge system. Water motor alarms and alarm pressure switches will activate.

Manual Operation

Any time the manual release handle is pulled, water will be released from the piston, and the valve will actuate, thus allowing water into the deluge system. Water motor alarms and alarm pressure switches will activate.

DISCONTINUED PRODUCT

⚠ WARNING



- This product must be installed by an experienced, trained installer, in accordance with the instructions provided with each valve. These instructions contain important information.

Failure to follow these instructions may result in serious personal injury, property damage, or valve leakage.

If you need additional copies of this product literature or the valve installation instructions, or if you have any questions about the safe installation and use of this device, contact Victaulic Company, P.O. Box 31, Easton, PA 18044-0031 USA, Telephone: 001-610-559-3300.

This product shall be manufactured by Victaulic Company. All products to be installed in accordance with current Victaulic installation/assembly instructions. Victaulic reserves the right to change product specifications, designs and standard equipment without notice and without incurring obligations.