

Victaulic® Series UM Universal Manifold Assembly



1.0 PRODUCT DESCRIPTION

Available Sizes

- 1 ¼ – 8"/DN32 – DN200

Maximum Working Pressure

- Up to 300 psi/2068 kPa/21 Bar

Application

- Fire protection system control module includes test and drain valve, waterflow detector, pressure gauge, flexible drain connection and adjustable pressure relief valve (175 – 310 psi/1206 – 2137 kPa adjustable set pressure).

Configurations

- Optional control valve: Series 705 Butterfly Valve or Series 728 Ball Valve

Included Components

- Series UTD (Universal Test Drain) with integrated Series ARV (Adjustable Relief Valve)
- Quick Drain Hose
- Vane Type Flow Switch
- 1 ¼ – 2"/DN32 – DN50 UM use saddle type 2" VSR flow switch
- 2 ½" – 8"/DN80 – DN200 UM use saddle type VSR flow switch for the corresponding size
- 1 ¼ – 8"/DN32 – DN200 System-side pressure gauge 400 psi/2750 kPa/27.5 bar

Available End Connections

- Victaulic Original Groove System (OGS) standard groove

2.0 CERTIFICATION/LISTINGS

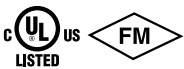

3.0 SPECIFICATIONS – MATERIAL

Valve body: Cast ductile iron conforming to ASTM A536, Grade 65-45-12.

Waterflow Detector: Vane type waterflow detector with sealed retard, and mechanical delay adjustment. Cover includes tamper resistant security screws and tool.

ALWAYS REFER TO ANY NOTIFICATIONS AT THE END OF THIS DOCUMENT REGARDING PRODUCT INSTALLATION, MAINTENANCE OR SUPPORT.

4.0 DIMENSIONS

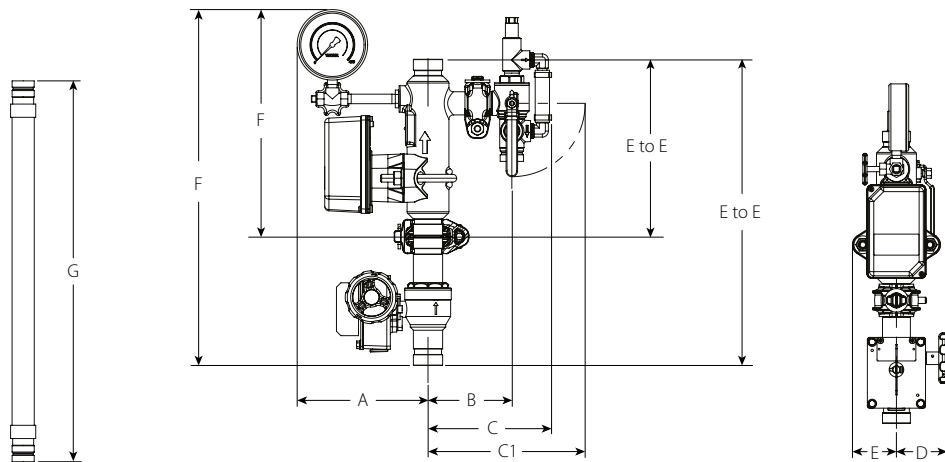

Size		Dimensions													Weight Approx. (Each)	
Nominal	Actual Outside Diameter	E to E with control valve	E to E without control valve	A	B	C	C1	D	E	F with control valve	F without control valve	G	Series UTD Valve Size (Nominal)	Series UTD Test Orifice	with control valve	without control valve
inches DN	inches mm	inches mm	inches mm	inches mm	inches mm	inches mm	inches mm	inches mm	inches mm	inches mm	inches mm	inches mm	inches DN	K-Factor S.I.	lb kg	lb kg
1 ¼ DN32	1.660 42.4	17.38 441	10.00 254	7.38 187	4.75 121	7.00 178	8.88 225	3.00 76	2.63 67	20.25 514	12.88 327	24.00 610	1.00 25	2.8 4.0	22 9.98	13 5.90
1 ½ DN40	1.900 48.3	17.38 441	10.00 254	7.38 187	4.75 121	7.00 178	8.88 225	3.00 76	2.63 67	20.25 514	12.88 327	24.00 610	1.00 25	2.8 4.0	22 9.98	13 5.90

NOTE

- When Series UTD Valve Size (Nominal) is 1"/25 mm, flexible drain hose connection utilizes FireLock IGS™ groove profile.

4.0 DIMENSIONS (CONTINUED)

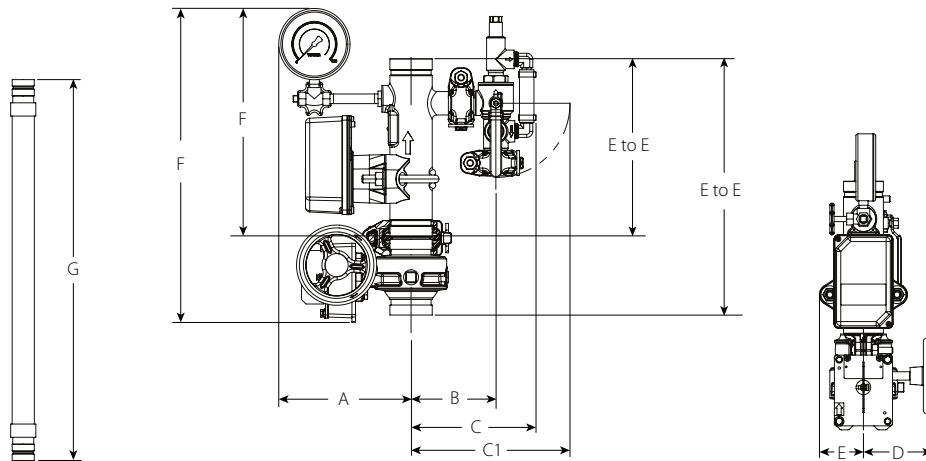

Size		Dimensions													Weight Approx. (Each)	
Nominal inches DN	Actual Outside Diameter inches mm	E to E with control valve inches mm	E to E without control valve inches mm	A inches mm	B inches mm	C inches mm	C1 inches mm	D inches mm	E inches mm	F with control valve inches mm	F without control valve inches mm	G inches mm	Series UTD Valve Size (Nominal) inches DN	Series UTD Test Orifice K-Factor S.I.	with control valve lb kg	without control valve lb kg
2 DN50	2.375 60.3	14.38 365	10.00 254	7.38 187	4.75 121	7.00 178	8.88 225	4.13 105	2.63 67	17.63 448	12.88 327	24.00 610	1.00 25	4.2 6.1	24 10.89	13 5.90
2½	2.875 73.0	13.88 352	10.00 254	7.63 194	5.88 149	8.38 213	10.75 273	4.13 105	2.63 67	17.50 445	12.88 327	24.00 610	1.25 32	4.2 6.1	29 13.15	17 7.71
DN65	3.000 76.1	13.88 352	10.00 254	7.63 194	5.88 149	8.38 213	10.75 273	4.13 105	2.63 67	17.50 445	12.88 327	24.00 610	1.25 32	4.2 6.1	29 13.15	17 7.71
3 DN80	3.500 88.9	14.88 378	11.00 279	8.00 203	6.13 156	8.63 219	11.00 279	4.13 105	2.88 73	18.50 470	13.88 352	24.00 610	1.25 32	4.2 6.1	33 14.97	20 9.07

NOTE

- When Series UTD Valve Size (Nominal) is 1/25 mm, flexible drain hose connection utilizes FireLock IGS™ groove profile.

4.0 DIMENSIONS (CONTINUED)

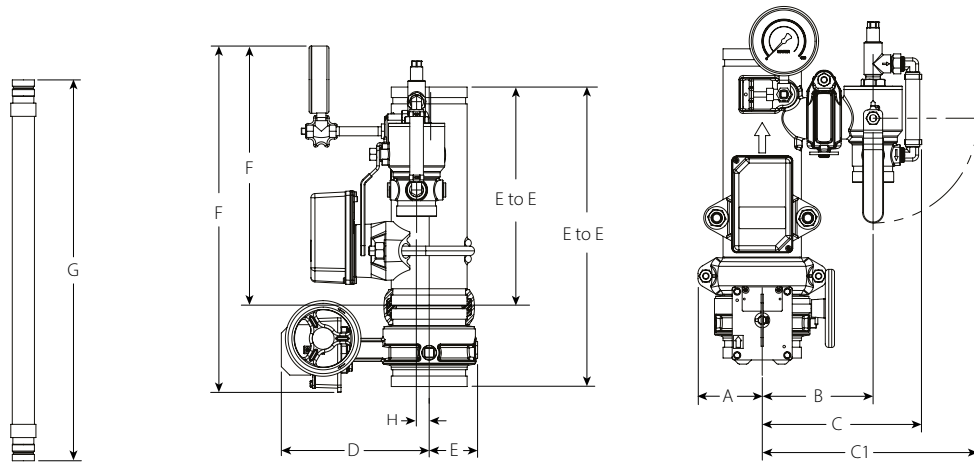

Size		Dimensions														Weight Approx. (Each)	
Nominal inches DN	Actual Outside Dia. inches mm	E to E with control valve inches mm	E to E without control valve inches mm	A inches mm	B inches mm	C inches mm	C1 inches mm	D inches mm	E inches mm	F with control valve inches mm	F without control valve inches mm	G inches mm	H inches mm	Series UTD Valve Size (Nominal) inches DN	Series UTD Test Orifice K-Factor S.I.	with control valve lb kg	without control valve lb kg
4 DN100	4.500	17.88	13.00	3.75	6.38	9.25	12.38	8.75	2.88	20.63	15.50	36.00	0.75	2.00	5.6	44	17
	114.3	454	330	95	162	235	314	222	73	524	394	914	19	51	8.1	19.96	7.71
6 DN150	6.500	19.00	13.00	5.13	7.38	10.25	13.38	11.38	4.25	21.50	15.50	36.00	1.50	2.00	5.6	66	34
	165.1	483	330	130	187	260	340	289	108	546	394	914	38	51	8.1	29.94	15.42

4.0 DIMENSIONS (CONTINUED)

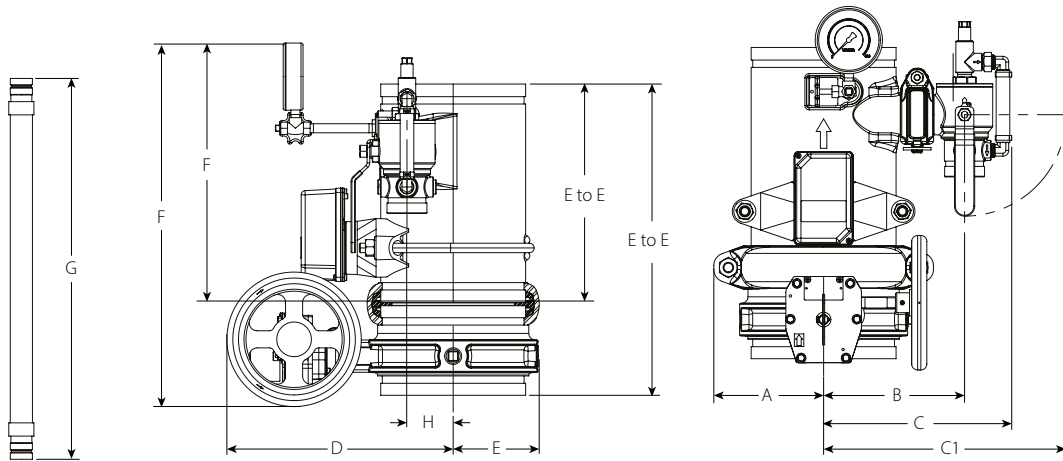

Size		Dimensions														Weight Approx. (Each)	
Nominal	Actual Outside Dia.	E to E with control valve	E to E without control valve	A	B	C	C1	D	E	F with control valve	F without control valve	G	H	Series UTD Valve Size (Nominal)	Series UTD Test Orifice	with control valve	without control valve
inches DN	inches mm	inches mm	inches mm	inches mm	inches mm	inches mm	inches mm	inches mm	inches mm	inches mm	inches mm	inches mm	inches mm	inches DN	K-Factor S.I.	lb kg	lb kg
8 DN200	8.625 219.1	18.50 470	13.00 330	6.50 165	8.38 213	11.25 286	14.38 365	13.50 343	5.13 130	21.63 549	15.50 394	36.00 914	2.75 70	2.00 51	5.6 8.1	91 41.28	54 24.49

5.0 PERFORMANCE

Size		Equivalent Length of Sch. 40 Pipe ¹		Flow Characteristics		Performance
Nominal inches DN	Actual Outside Diameter inches mm	with control valve	without control valve	Cv/Kv Values with control valve	Cv/Kv Values without control valve	Maximum Working Pressure psi kPa
		feet meters	feet meters	Full Open	Full Open	
1 ¼ DN32	1.660	5.75	5.25	47.65	49.33	300 2068
	42.4	1.8	1.6	41	43	
1 ½ DN40	1.900	6	5.875	70.66	72.53	300 2068
	48.3	1.8	1.8	61	63	
2 DN50	2.375	12.25	6.625	95.39	130.61	300 2068
	60.3	3.7	2.0	83	113	
2 ½	2.875	9.875	5.25	149.98	218.87	300 2068
	73.0	3.0	1.6	130	189	
DN65	3.000	9.875	5.25	149.98	218.87	300 2068
	76.1	3.0	1.6	130	189	
3 DN80	3.500	9	4.125	298	433.2	300 2068
	88.9	2.7	1.3	258	375	
4 DN100	4.500	8.5	3	594.94	964.95	300 2068
	114.3	2.6	0.9	515	835	
6	6.500	12	4.5	1472.2	2256.53	300 2068
	165.1	3.7	1.4	1273	1952	
DN150	6.625	12	4.5	1472.2	2256.53	300 2068
	168.3	3.7	1.4	1273	1952	
8 DN200	8.625	17.5	4.125	2500.92	5035.24	300 2068
	219.1	5.3	1.3	2163	4355	

¹ Equivalent length of Sch. 40 pipe calculated using the hazen-williams formula with a roughness constant of c=120.

5.0 PERFORMANCE

Series UM Friction Loss with Control Valve (including water flow switch)

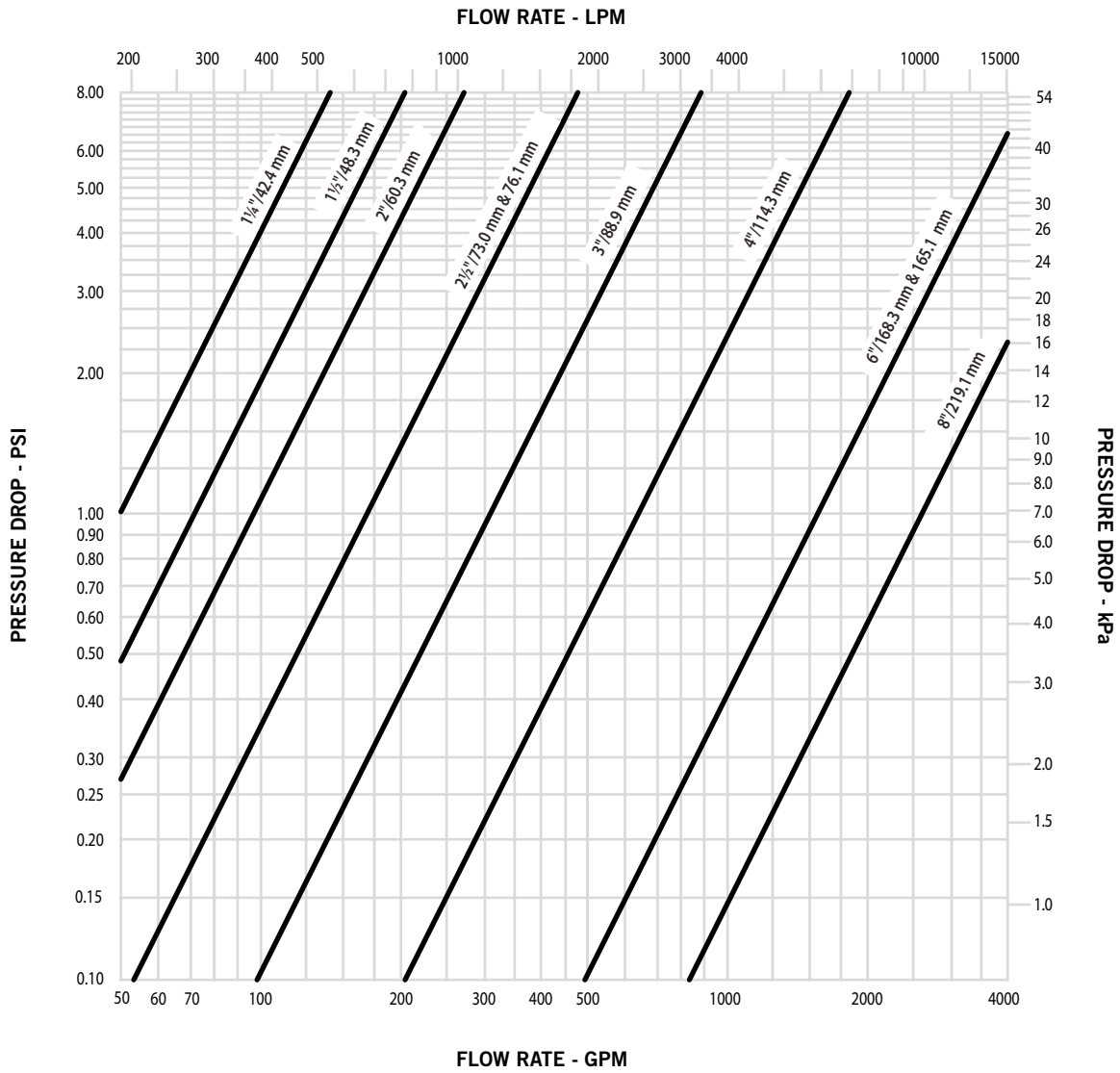

5.0 PERFORMANCE (CONTINUED)

Series UM Friction Loss without Control Valve (including water flow switch)

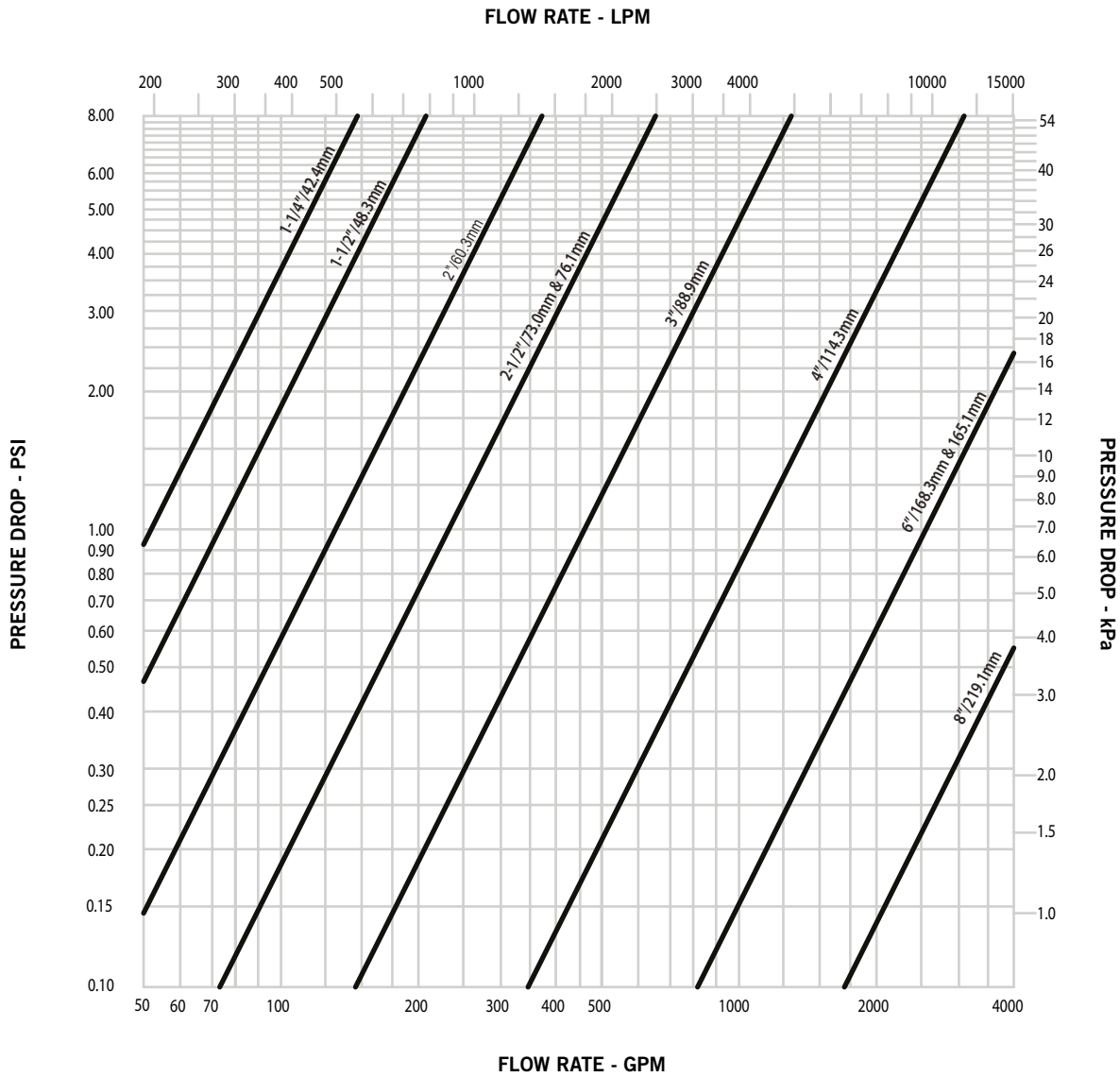

6.0 NOTIFICATIONS

⚠ WARNING



- Read and understand all instructions before attempting to install any Victaulic products.
- Always verify that the piping system has been completely depressurized and drained immediately prior to installation, removal, adjustment, or maintenance of any Victaulic products.
- Confirm that any equipment, branch lines, or sections of piping that may have been isolated for/during testing or due to valve closures/positioning are identified, depressurized, and drained intermediately prior to installation, removal, adjustment, or maintenance of any Victaulic products.
- Wear safety glasses, hardhat, and foot protection.

Failure to follow these instructions could result in death or serious personal injury and property damage.

- These products shall be used only in fire protection systems that are designed and installed in accordance with current, applicable National Fire Protection Association (NFPA 13, 13D, 13R, etc.) standards, or equivalent standards, and in accordance with applicable building and fire codes. These standards and codes contain important information regarding protection of systems from freezing temperatures, corrosion, mechanical damage, etc.
- The installer shall understand the use of this product and why it was specified for the particular application.
- The installer shall understand common industry safety standards and potential consequences of improper product installation.

Failure to follow installation requirements and local and national codes and standards could compromise system integrity or cause system failure, resulting in death or serious personal injury and property damage.

7.0 REFERENCE MATERIALS

- [10.17: Series 728 FireLock™ Ball Valve](#)
- [10.54: FireLock™ Innovative Groove System IIGS™](#)
- [10.64: FireLock™ Installation-Ready™ Rigid Couplings Style 009N and Style 109](#)
- [10.80: Series 765 FireLock™ High Pressure Butterfly Valve](#)
- [10.81: Series 705 FireLock™ Butterfly Valve](#)
- [30.73: Series UTD Universal Test and Drain](#)
- [30.74: Series ARV Adjustable Relief Valve](#)
- [30.75: Series FTV Flow Test Valve](#)
- [I-UM: Series UM Universal Manifold Assembly Installation Manual](#)

User Responsibility for Product Selection and Suitability

Each user bears final responsibility for making a determination as to the suitability of Victaulic products for a particular end-use application, in accordance with industry standards and project specifications, as well as Victaulic performance, maintenance, safety, and warning instructions. Nothing in this or any other document, nor any verbal recommendation, advice, or opinion from any Victaulic employee, shall be deemed to alter, vary, supersede, or waive any provision of Victaulic Company's standard conditions of sale, installation guide, or this disclaimer.

Intellectual Property Rights

No statement contained herein concerning a possible or suggested use of any material, product, service, or design is intended, or should be construed, to grant any license under any patent or other intellectual property right of Victaulic or any of its subsidiaries or affiliates covering such use or design, or as a recommendation for the use of such material, product, service, or design in the infringement of any patent or other intellectual property right. The terms "Patented" or "Patent Pending" refer to design or utility patents or patent applications for articles and/or methods of use in the United States and/or other countries.

Note

This product shall be manufactured by Victaulic or to Victaulic specifications. All products to be installed in accordance with current Victaulic installation/assembly instructions. Victaulic reserves the right to change product specifications, designs and standard equipment without notice and without incurring obligations.

Installation

Reference should always be made to the Victaulic installation handbook or installation instructions of the product you are installing. Handbooks are included with each shipment of Victaulic products, providing complete installation and assembly data, and are available in PDF format on our website at www.victaulic.com.

Warranty

Refer to the Warranty section of the current Price List or contact Victaulic for details.

Trademarks

Victaulic and all other Victaulic marks are the trademarks or registered trademarks of Victaulic Company, and/or its affiliated entities, in the U.S. and/or other countries.