

## Style 230 Non-Restrained Flexible Coupling

Victaulic Bolted Split-Sleeve Products (VBSP) Style 230 carbon steel couplings (formerly Depend-O-Lok ExE) provide a non-restrained, flexible pipe joint that satisfies the requirements set forth by the AWWA C227 Standard for Bolted, Split-Sleeve Restrained and Non-Restrained Couplings for Plain-End Pipe.

This style of coupling is typically used in buried or exposed pipe applications for flexible field joint connections where either joint restraint due to thrust is not a requirement or can be accommodated using an external joint harness system such as AWWA M11 restraint harnesses. External restraints must be installed to ensure the coupling does not exceed published values for allowable movement. Typical applications include water and wastewater pipelines, inlet and drainage piping and other piping applications that require a non-restrained flexible connection. The coupling provides ease of installation and comes standard with an epoxy coating for protection against corrosion. The use of a heat-shrink sleeve or tape system can be used with minimal effort due to the low profile configuration.

The dual-arched mechanical coupling body houses o-ring gaskets that provide the radial seal around the circumference of the pipe, while a sealing plate provides for the axial seal across the coupling body and pipe joint. The Style 230 coupling housing is designed to accommodate hoop stress to meet system pressure requirements while maintaining a leak-proof joint seal. The Style 230 couplings also perform at negative pipe pressures up to full vacuum. The o-ring gasket is not pressure responsive and therefore does not require internal pipe pressure to assist with the seal. The arched cross-sectional shape of the coupling provides for a high section modulus to resist forces encountered during negative pressure (submerged) or vacuum service.

Style 230 couplings are available in standard nominal sizes from 8 – 144"/200 – 3600 mm with larger sizes available based on design and application requirements. The Style 230 non-restrained coupling can accommodate operating pressures up to 400 psi/2750 kPa depending on the actual pipe diameter. For pressures and sizes not shown in the dimension and performance tables contact Victaulic for information on our engineered products by visiting the Victaulic web site.

Style 230/230S couplings provide a flexible pipe connection and are not designed or intended to transfer significant shear, bending or axial loads across the pipe joint. Therefore a single coupling will not allow for differential settlement to occur at the joint. However a minimum of two flexible couplings designed to allow dynamic (in-service) deflection and installed in combination can be used to accommodate differential settlement at a pipe joint or between a pipeline and a structure. Style 230 couplings provide 1/2"/15mm of axial movement and are not designed for use as an expansion coupling. Victaulic recommends Style 233/233S couplings for this purpose as they are specifically designed to allow for dynamic deflection and provide thrust restraint at the joint. Refer to submittal publications 60.07 and 60.08 for product details and 26.20 for guidelines regarding the use of these couplings in differential settlement application.

All flexible mechanical couplings should be properly supported to minimize or eliminate undesirable loads at the joint. Pipe support requirements are defined within the Victaulic Application Guidelines document. Please see submittal 26.20.

For proper closure tool selection see column marked Tool Type on page 6-8.



8 – 144"/200 – 3600mm

**JOB OWNER**

System No. \_\_\_\_\_

Location \_\_\_\_\_

**CONTRACTOR**

Submitted By \_\_\_\_\_

Date \_\_\_\_\_

**ENGINEER**

Spec Sect \_\_\_\_\_ Para \_\_\_\_\_

Approved \_\_\_\_\_

Date \_\_\_\_\_

## Style 230 Non-Restrained Flexible Coupling

### PRODUCT GUIDE

Product Style Number Guide			
Submittal Number	Style Number	Coupling/Body Material	Application
60.01	230	Carbon Steel	Non-Restrained Coupling
60.02	230S	Stainless Steel	Non-Restrained Coupling
60.03	231	Carbon Steel	Expansion Coupling
60.04	231S	Stainless Steel	Expansion Coupling
60.05	232	Carbon Steel	Restrained Coupling
60.06	232S	Stainless Steel	Restrained Coupling
60.07	233	Carbon Steel	Restrained Coupling For Dynamic Joint Deflection
60.08	233S	Stainless Steel	Restrained Coupling For Dynamic Joint Deflection
60.09	234	Carbon Steel	Restrained Single-Gasket Coupling
60.10	234S	Stainless Steel	Restrained Single-Gasket Coupling

### SEGMENTED COUPLINGS

The Style 230 dimensional tables list the minimum number of coupling housing segments for a particular pipe size. For special applications, non-restrained couplings are available in two (or more) segments to allow for installation of the coupling over an existing pipe joint or to facilitate ease of handling for larger size couplings. The o-ring gaskets (except Silicone) can be furnished "split" to allow for field bonding when an existing pipe joint configuration does not allow for installation of a complete o-ring onto the pipe end.

### BODY TYPE

#### Cross-Sections

NOTE: Body type is not optional and will be determined by system requirements.

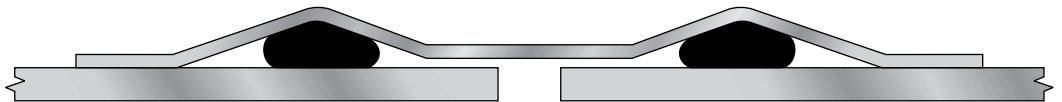

**Type 1** coupling is the basic split-sleeve coupling that provides for a flexible, non-restrained pipe joint and is generally used for smaller diameter, low pressure applications.

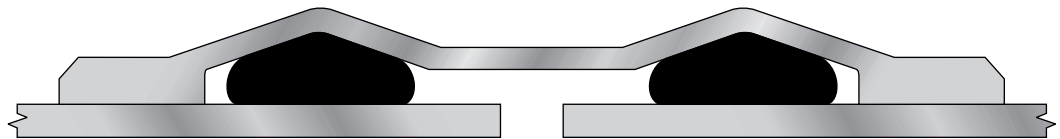

**Type 2** coupling is a shouldered coupling. This coupling is designed to accommodate higher pressures for certain pipe diameters. The shoulders welded to the edge of the coupling body provide additional cross-sectional stiffness and typically allow for more angular deflection at the joint than a Type 1 coupling.

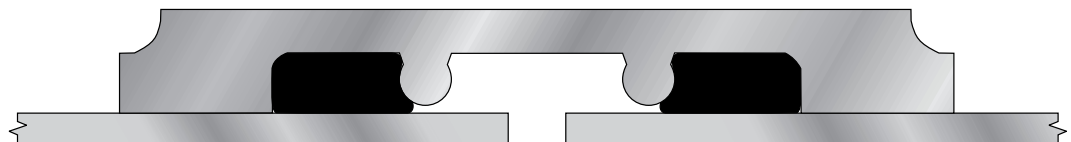

**Type 3** coupling is a flat-body variation of the Type 2 with a reinforced, offset closure and thick body design for high pressure applications.

## Style 230 Non-Restrained Flexible Coupling For Carbon Steel Pipe

### COUPLING COMPONENTS

**1. Body** – Dual arch cross-section split sleeve used on Type 1 and 2. A thick, flat cross section is used for Type 3.

**2. Shoulders (Type 2 and 3 only)** – Provide additional stiffness, allow for larger o-ring gaskets to accommodate angular deflection at the pipe joint.

**3. Closure Plates** – Low profile bolt pads for installation and tightening of coupling; gap between plates of installed coupling allows for field flexibility.

**4. Sealing Plate** – Provides axial seal across the coupling body and pipe joint.

**5. O-ring Gaskets** – Provide circumferential seal.

**6. Fasteners**

Studs – High Strength Threaded Rod

Nuts – Heavy Hex Nuts

Washers – SAE small pattern flat washers

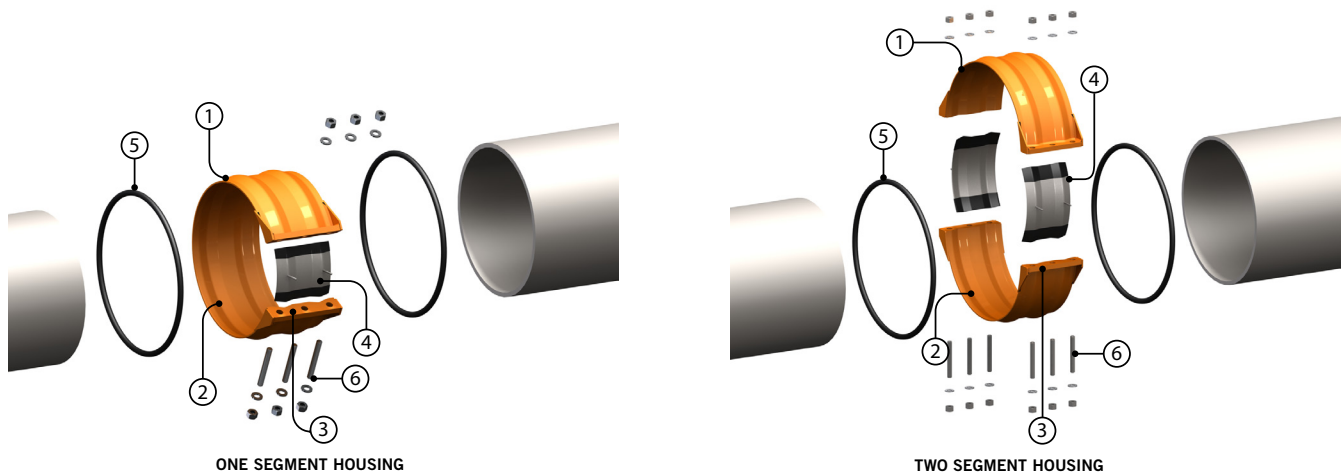

## Style 230 Non-Restrained Flexible Coupling

### MATERIAL SPECIFICATIONS

#### Body

Carbon Steel conforming to ASTM A36 or ASTM A1011 (for gauge thicknesses)

#### Shoulders (Type 2 and 3)

Carbon Steel conforming to ASTM A36

#### Closure Plates

Carbon Steel conforming to ASTM A36

#### Sealing Plate

Stainless Steel conforming to ASTM A240 316L

#### O-ring Gaskets

Standard (Specify choice on order):

- **EPDM** -30°F to +230°F/-34°C to +110°C  
Cold and hot water within allowable temperature range; dilute acids; excellent resistance to the deteriorative effects of ozone, oxygen, heat and most chemicals not involving hydrocarbons. NOT RECOMMENDED FOR PETROLEUM SERVICES.
- **Silicone** -30°F to +350°F/-34°C to +177°C  
Dry, hot air applications; excellent resistance to many chemicals. NOT RECOMMENDED FOR HOT WATER OR STEAM APPLICATIONS.
- **Isoprene** -40°F to +160°F/-40°C to +71°C  
Water; salt water; sewage; good resistance to oxygen and dilute acids  
  
Services listed are general service recommendations only. Refer to a chemical elastomer guide for specific applications and suitability of gasket material for services that are not listed.

Optional gasket (specify choice on order):

- **Nitrile** -20°F to +180°F/-28°C to +82°C  
Water; petroleum products, vegetable and mineral oils; air with oil vapors within allowable temperature range; good resistance to hydrocarbons; acids and bases.
- **Fluoroelastomer** +20°F to +300°F/-7°C to +149°C  
Outstanding resistance to heat and most chemicals.
- **Neoprene** -30°F to +180°F/-34°C to +82°C  
Water and wastewater; good resistance to ozone, effects of UV and some oils.

#### Fasteners

**Studs** - Carbon Steel conforming to ASTM A193 Grade B7 zinc plated.

Optional: Stainless Steel conforming to ASTM A193 Grade B8M 316 Class 2

**Nuts** - Heavy hex nuts

Carbon Steel conforming to ASTM A194 Grade 2H zinc plated

Optional: Stainless Steel conforming to ASTM A194 Grade 8M 316

**Washers** - Carbon Steel SAE small pattern flat washers conforming to ASTM F436 SAE pattern zinc plated

Optional: Stainless Steel Type 316 SAE pattern.

## Style 230 Non-Restrained Flexible Coupling

### LININGS AND COATINGS

Standard (specify choice on order):

- **Liquid Epoxy:**

Liquid epoxy is applied per AWWA C210, 16 mils minimum DFT and is NSF61 approved. Epoxy can be applied as a primer for field applied top coat where UV protection due to sunlight exposure is required. This coating offers excellent corrosion protection for buried applications.

- **Fusion Bonded Epoxy:**

Fusion bonded epoxy is applied with an electrostatic spray system using a long cure epoxy powder that offers excellent chemical resistance and corrosion protection. Fusion bonded epoxy is applied per AWWA C213, 12 mils minimum DFT and is NSF61 approved.

Optional (specify choice on order):

- **Phenolic Alkyd Primer:**

Phenolic Alkyd primer is a lead-free and chromate-free, fast-drying, corrosion-resistant primer that accepts a variety of high-performance topcoats, but is not recommended for immersion service by itself. This primer system is typically applied at 2 to 3 mils DFT.

- **Other Coating Systems (Available Upon Request):**

A water based enamel coating is available. This paint offers an aesthetic coating for minimal protection, short-term installations or where corrosion protection is not a consideration. Fusion bonded nylon for chemical and abrasion resistance, as well as other coatings such as organic zinc primers and hot dipped galvanizing may also be available.

### PIPE END DIMENSIONAL TOLERANCE AND OVALITY

For specific pipe diameter tolerances, pipe ovality (roundness) requirements and minimum/maximum pipe diameter allowance, refer to the tables included in the Installation Manuals (below) and 26.20 Application Guidelines.

I-230.S1 - Styles 230/230S Non-Restrained Coupling (Types 1 & 2, One Segment)

I-230.S2 - Styles 230/230S Non-Restrained Coupling (Types 1 & 2, Two Segments)

I-230.T3S2 - Style 230 Non-Restrained Coupling (Type 3, Two Segments)



# Style 230 Non-Restrained Flexible Coupling

**DIMENSIONS**

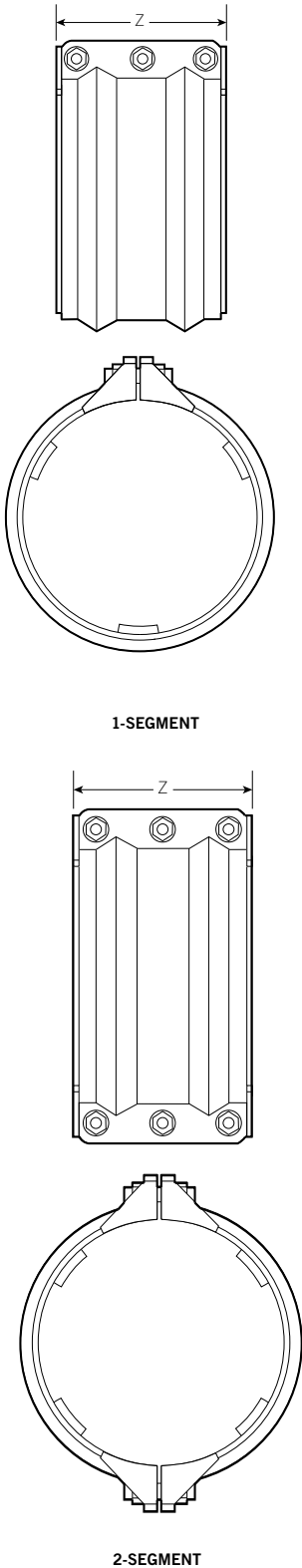

(1)	(2)	(3)	Coupling Dimensions		(4)	(5)	(6)		
Nominal Pipe Size In./mm	Actual Pipe O.D. Range In./mm	Maximum Working Pressure psi/kPa	Body Thickness In.	Width (Z) In./mm	Min. No. of Coupling Segments	No. of Fasteners - Fastener Dimensions Dia. x Length In. x In.	Approximate Weight Each Lbs/Kg.	Body Type	Tool Type
54 1350	51.00 - 56.88 1295.4 - 1444.8	100 690	¼	12.50 317.5	1	4 - 7/8 x 8	261.0 118.4	2	C
		200 1375	⅜	12.50 317.5	2	8 - 7/8 x 8	459.0 208.2	2	C
		300 2065	½	14.50 368.3	2	8 - 1 x 8	691.0 313.4	2	C
		350 2410	⅝	14.50 368.3	2	8 - 1 x 8	834.0 378.3	2	C
		400 2750	¾	16.50 419.1	2	10 - 1¼ x 10	1245.0 564.7	3	D
60 1500	57.00 - 62.88 1447.8 - 1597.2	100 690	¼	12.50 317.5	2	8 - 7/8 x 8	321.0 145.6	2	C
		200 1375	⅜	12.50 317.5	2	8 - 7/8 x 8	502.0 227.7	2	C
		250 1725	½	14.50 368.3	2	8 - 1 x 8	756.0 342.9	2	C
		300 2065	⅝	14.50 368.3	2	8 - 1 x 8	912.0 413.7	2	C
		400 2750	¾	16.50 419.1	2	10 - 1¼ x 10	1358.0 616.0	3	D
66 1650	63.00 - 68.88 1600.2 - 1749.6	175 1200	⅜	12.50 317.5	2	8 - 7/8 x 8	536.0 243.1	2	C
		250 1725	½	14.50 368.3	2	8 - 1 x 8	805.0 365.1	2	C
		300 2065	⅝	14.50 368.3	2	8 - 1 x 8	990.0 449.1	2	C
		350 2410	¾	16.50 419.1	2	10 - 1¼ x 10	1445.0 655.4	3	D
		400 2750	1	16.50 419.1	2	10 - 1 ¼ x 10	1767.0 801.5	3	D
72 1800	69.00 - 74.88 1752.6 - 1902.0	175 1200	⅜	12.50 317.5	2	8 - 7/8 x 8	579.0 262.6	2	C
		200 1375	½	14.50 368.3	2	8 - 1 x 8	870.0 394.6	2	C
		250 1725	⅝	14.50 368.3	2	8 - 1 x 8	1069.0 484.9	2	C
		300 2065	¾	16.50 419.1	2	10 - 1¼ x 10	1564.0 709.4	3	D
		400 2750	1	16.50 419.1	2	10 - 1 ¼ x 10	1917.0 869.5	3	D
78 1950	75.00 - 80.88 1905 - 2054.4	150 1035	⅜	12.50 317.5	2	8 - 7/8 x 8	613.0 278.1	2	C
		200 1375	½	14.50 368.3	2	8 - 1 x 8	934.0 423.7	2	C
		250 1725	⅝	14.50 368.3	2	8 - 1 x 8	1146.0 519.8	2	C
		300 2065	¾	16.50 419.1	2	10 - 1¼ x 10	1651.0 748.9	3	D
		400 2750	1	16.50 419.1	2	10 - 1 ¼ x 10	2024.0 918.1	3	D

- (1) Couplings must be used on pipe with a minimum wall thickness that meets the requirements of AWWA C200 for carbon steel pipe.
  - (2) Actual pipe O.D. required at time of order. For actual pipe O.D. round down to the nearest 1/8" to determine proper coupling size required.
  - (3) For allowable test or transient pressure, the maximum working pressure may be increased to 1½ times the values shown.
  - (4) 1-segment couplings may be available as 2-segment couplings to allow for in-place pipe installations. Contact Victaulic for details.
  - (5) Coupling weights are based on nominal pipe diameter and include all accessories. Weight may vary based on actual size of pipe.
  - (6) Closure Tool Recommendations:
    - A= CTM-01 Small Manual Closure Tool
    - B= CTM-02 Large Manual Closure Tool
    - C= CTH-01 10-Ton Hydraulic Closure Tool
    - D= CTH-02 25-Ton Hydraulic Closure Tool
- \*For more details on closure tools refer to page 12.  
 Note: The data in this table only applies when carbon steel couplings are being used on carbon steel pipe.

# Style 230 Non-Restrained Flexible Coupling

**DIMENSIONS**

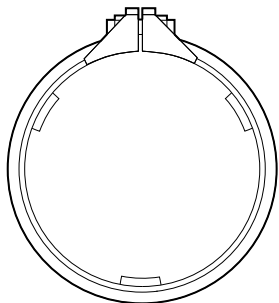
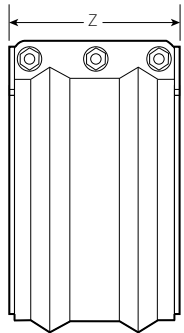

1-SEGMENT

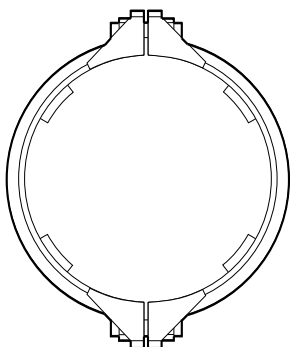
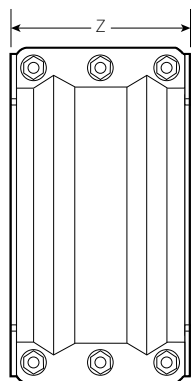

2-SEGMENT

(1)	(2)	(3)	Coupling Dimensions		(4)	(5)	(6)	(7)	(8)
			Body Thickness In.	Width (Z) In./mm					
84 2100	81.00 - 86.88 2057.4 - 2206.8	150 1035	3/8	12.50 317.5	2	8 - 7/8 x 8	656.0 297.6	2	C
		200 1375	1/2	14.50 368.3	2	8 - 1 x 8	984.0 446.3	2	C
		250 1725	5/8	14.50 368.3	2	8 - 1 x 8	1205.0 546.6	2	C
		300 2065	3/4	16.50 419.1	2	10 - 1 1/4 x 10	1763.0 799.7	3	D
		350 2410	1	16.50 419.1	2	10 - 1 1/4 x 10	2165.0 982.0	3	D
90 2250	87.00 - 92.88 2209.8 - 2359.2	100 690	3/8	12.50 317.5	2	8 - 7/8 x 8	690.0 313.0	2	C
		150 1035	1/2	14.50 368.3	2	8 - 1 x 8	1032.0 468.1	2	C
		200 1375	5/8	14.50 368.3	2	8 - 1 x 8	1282.0 581.5	2	C
		250 1725	3/4	16.50 419.1	2	10 - 1 1/4 x 10	1857.0 842.3	3	D
		350 2410	1	16.50 419.1	2	10 - 1 1/4 x 10	2280.0 1034.2	3	D
96 2400	93.00 - 101.88 2362.2 - 2587.8	100 690	3/8	12.50 317.5	2	8 - 7/8 x 8	744.0 337.5	2	C
		150 1035	1/2	14.50 368.3	2	8 - 1 x 8	1112.0 504.4	2	C
		200 1375	3/4	16.50 419.1	2	10 - 1 1/4 x 10	1943.0 881.3	3	D
		300 2065	1	16.50 419.1	2	10 - 1 1/4 x 10	2386.0 1082.3	3	D
108 2700	102.00 - 113.88 2590.8 - 2892.6	100 690	3/8	12.50 317.5	2	8 - 7/8 x 8	810.0 367.4	2	C
		150 1035	1/2	14.50 368.3	2	8 - 1 x 8	1226.0 556.1	2	C
		200 1375	3/4	16.50 419.1	2	10 - 1 1/4 x 10	2118.0 960.7	3	D
		300 2065	1	16.50 419.1	2	10 - 1 1/4 x 10	2601.0 1179.8	3	D
120 3000	114.00 - 125.88 2895.6 - 3197.4	75 515	3/8	12.50 317.5	2	8 - 7/8 x 8	887.0 402.3	2	C
		125 860	1/2	14.50 368.3	2	8 - 1 x 8	1339.0 607.4	2	C
		200 1375	3/4	16.50 419.1	2	10 - 1 1/4 x 10	2323.0 1053.7	3	D
		250 1725	1	16.50 419.1	2	10 - 1 1/4 x 10	2857.0 1295.9	3	D
144 3600	126.00 - 150.00 3200.4 - 3810.0	75 515	3/8	12.50 317.5	2	8 - 7/8 x 8	1022.0 463.6	2	C
		100 690	1/2	14.50 368.3	2	8 - 1 x 8	1551.0 703.5	2	C
		150 1035	3/4	16.50 419.1	2	10 - 1 1/4 x 10	2672.0 1212.0	3	D
		200 1375	1	16.50 419.1	2	10 - 1 1/4 x 10	3286.0 1490.5	3	D

- (1) Couplings must be used on pipe with a minimum wall thickness that meets the requirements of AWWA C200 for carbon steel pipe.
- (2) Actual pipe O.D. required at time of order. For actual pipe O.D. round down to the nearest 1/8" to determine proper coupling size required.
- (3) For allowable test or transient pressure, the maximum working pressure may be increased to 1 1/2 times the values shown.
- (4) 1-segment couplings may be available as 2-segment couplings to allow for in-place pipe installations. Contact Victaulic for details.
- (5) Coupling weights are based on nominal pipe diameter and include all accessories. Weight may vary based on actual size of pipe.
- (6) Closure Tool Recommendations:\*

- A= CTM-01 Small Manual Closure Tool
- B= CTM-02 Large Manual Closure Tool
- C= CTH-01 10-Ton Hydraulic Closure Tool
- D= CTH-02 25-Ton Hydraulic Closure Tool

\*For more details on closure tools refer to page 12.

Note: The data in this table only applies when carbon steel couplings are being used on carbon steel pipe.



## Style 230 Non-Restrained Flexible Coupling

### PERFORMANCE

Nominal Pipe Size In./mm	(1)			Body Type	(2) Pipe End Separation Min - Max In./mm	(3) Max. Allow. Static Deflection Degrees
	Maximum Working Pressure psi/kPa Carbon Steel	Maximum Working Pressure psi/kPa Stainless Steel	Maximum Working Pressure psi/kPa Ductile Iron			
8 200	200 1375	200 1375	200 1375	1	0 - 1.50 0 - 38.1	4° 0'
10 250	200 1375	200 1375	200 1375	1	0 - 1.50 0 - 38.1	4° 0'
12 300	200 1375	200 1375	200 1375	1	0 - 1.50 0 - 38.1	4° 0'
14 350	200 1375	200 1375	200 1375	1	0 - 1.50 0 - 38.1	4° 0'
16 400	200 1375	200 1375	200 1375	1	0 - 1.50 0 - 38.1	3° 30'
	300 2065	300 2065	300 2065	2	0 - 1.50 0 - 38.1	3° 30'
18 450	200 1375	200 1375	200 1375	1	0 - 1.50 0 - 38.1	3° 30'
	300 2065	300 2065	300 2065	2	0 - 1.50 0 - 38.1	3° 30'
20 500	200 1375	200 1375	200 1375	1	0 - 1.50 0 - 38.1	3° 30'
	300 2065	300 2065	300 2065	2	0 - 1.50 0 - 38.1	3° 30'
24 600	100 690	100 690	100 690	1	0 - 1.50 0 - 38.1	3° 0'
	200 1375	200 1375	200 1375	2	0 - 1.50 0 - 38.1	3° 0'
	300 2065	300 2065	300 2065	2	0 - 3.00 0 - 76.2	3° 30'
30 750	100 690	100 690	100 690	1	0 - 1.50 0 - 38.1	2° 30'
	200 1375	200 1375	200 1375	2	0 - 3.00 0 - 76.2	3° 0'
	300 2065	300 2065	300 2065	2	0 - 3.00 0 - 76.2	3° 0'
36 900	75 515	75 515	75 515	1	0 - 1.50 0 - 38.1	2° 15'
	200 1375	200 1375	200 1375	2	0 - 3.00 0 - 76.2	3° 0'
	300 2065	300 2065	300 2065	2	0 - 3.00 0 - 76.2	3° 0'
42 1050	50 345	50 345	50 345	1	0 - 1.50 0 - 38.1	2° 0'
	150 1035	150 1035	150 1035	2	0 - 3.00 0 - 76.2	2° 30'
	250 1725	250 1725	250 1725	2	0 - 3.00 0 - 76.2	2° 30'
	300 2065	300 2065	300 2065	2	0 - 3.00 0 - 76.2	2° 30'
48 1200	50 345	50 345	50 345	1	0 - 1.50 0 - 38.1	1° 45'
	150 1035	150 1035	150 1035	2	0 - 3.00 0 - 76.2	2° 30'
	250 1725	250 1725	250 1725	2	0 - 3.00 0 - 76.2	2° 30'
	300 2065	300 2065	300 2065	2	0 - 3.00 0 - 76.2	2° 30'

(1) For allowable test or transient pressure, the maximum working pressure may be increased to 1½ times the values shown.

(2) Style 230 couplings provide ½"/15 mm of axial movement within the published pipe end separation range and are not designed for use as an expansion coupling.

(3) Published deflection values are intended for installation only. Allowable in-service or dynamic deflection is limited by the maximum allowable axial movement at the joint. Contact Victaulic for details.

# Style 230 Non-Restrained Flexible Coupling

## PERFORMANCE

Nominal Pipe Size In./mm	(1)			Body Type	(2) Pipe End Separation Min - Max In./mm	(3) Max. Allow. Static Deflection Degrees
	Maximum Working Pressure psi/kPa Carbon Steel	Maximum Working Pressure psi/kPa Stainless Steel	Maximum Working Pressure psi/kPa Ductile Iron			
54 1350	100 690	100 690	100 690	2	0 - 3.00 0 - 76.2	2° 0'
	200 1375	200 1375	200 1375	2	0 - 3.00 0 - 76.2	2° 0'
	300 2065	300 2065	300 2065	2	0 - 3.00 0 - 76.2	2° 0'
	350 2410	350 2410	350 2410	2	0 - 3.00 0 - 76.2	2° 0'
	400 2750	400 2750	400 2750	3	0 - 2.00 0 - 50.8	1° 0'
60 1500	100 690	100 690	100 690	2	0 - 3.00 0 - 76.2	1° 45'
	200 1375	200 1375	200 1375	2	0 - 3.00 0 - 76.2	1° 45'
	250 1725	250 1725	250 1725	2	0 - 3.00 0 - 76.2	1° 45'
	300 2065	300 2065	300 2065	2	0 - 3.00 0 - 76.2	1° 45'
	400 2750	400 2750	400 2750	3	0 - 2.00 0 - 50.8	1° 0'
66 1650	175 1200	175 1200	175 1200	2	0 - 3.00 0 - 76.2	1° 30'
	250 1725	250 1725	250 1725	2	0 - 3.00 0 - 76.2	1° 30'
	300 2065	300 2065	300 2065	2	0 - 3.00 0 - 76.2	1° 30'
	350 2410	350 2410	350 2410	3	0 - 2.00 0 - 50.8	0° 45'
	400 2750	400 2750	400 2750	3	0 - 2.00 0 - 50.8	0° 45'
72 1800	175 1200	175 1200	175 1200	2	0 - 3.00 0 - 76.2	1° 30'
	200 1375	200 1375	200 1375	2	0 - 3.00 0 - 76.2	1° 30'
	250 1725	250 1725	250 1725	2	0 - 3.00 0 - 76.2	1° 30'
	300 2065	300 2065	300 2065	3	0 - 2.00 0 - 50.8	0° 45'
	400 2750	400 2750	400 2750	3	0 - 2.00 0 - 50.8	0° 45'
78 1950	150 1035	150 1035	150 1035	2	0 - 3.00 0 - 76.2	1° 0'
	200 1375	200 1375	200 1375	2	0 - 3.00 0 - 76.2	1° 0'
	250 1725	250 1725	250 1725	2	0 - 3.00 0 - 76.2	1° 0'
	300 2065	300 2065	300 2065	3	0 - 2.00 0 - 50.8	0° 30'
	400 2750	400 2750	400 2750	3	0 - 2.00 0 - 50.8	0° 30'

- (1) For allowable test or transient pressure, the maximum working pressure may be increased to 1½ times the values shown.
- (2) Style 230 couplings provide ½"/15 mm of axial movement within the published pipe end separation range and are not designed for use as an expansion coupling.
- (3) Published deflection values are intended for installation only. Allowable in-service or dynamic deflection is limited by the maximum allowable axial movement at the joint. Contact Victaulic for details.

## Style 230 Non-Restrained Flexible Coupling

### PERFORMANCE

Nominal Pipe Size In./mm	(1)			Body Type	(2) Pipe End Separation Min - Max In./mm	(3) Max. Allow. Static Deflection Degrees
	Maximum Working Pressure psi/kPa Carbon Steel	Maximum Working Pressure psi/kPa Stainless Steel	Maximum Working Pressure psi/kPa Ductile Iron			
84 2100	150 1035	150 1035	150 1035	2	0 - 3.00 0 - 76.2	1° 0'
	200 1375	200 1375	200 1375	2	0 - 3.00 0 - 76.2	1° 0'
	250 1725	250 1725	250 1725	2	0 - 3.00 0 - 76.2	1° 0'
	300 2065	300 2065	300 2065	3	0 - 2.00 0 - 50.8	0° 30'
	350 2410	350 2410	350 2410	3	0 - 2.00 0 - 50.8	0° 30'
90 2250	100 690	100 690	100 690	2	0 - 3.00 0 - 76.2	1° 0'
	150 1035	150 1035	150 1035	2	0 - 3.00 0 - 76.2	1° 0'
	200 1375	200 1375	200 1375	2	0 - 3.00 0 - 76.2	1° 0'
	250 1725	250 1725	250 1725	3	0 - 2.00 0 - 50.8	0° 30'
	350 2410	350 2410	350 2410	3	0 - 2.00 0 - 50.8	0° 30'
96 2400	100 690	100 690	100 690	2	0 - 3.00 0 - 76.2	1° 0'
	150 1035	150 1035	150 1035	2	0 - 3.00 0 - 76.2	1° 0'
	200 1375	200 1375	200 1375	3	0 - 2.00 0 - 50.8	0° 30'
	300 2065	300 2065	300 2065	3	0 - 2.00 0 - 50.8	0° 30'
108 2700	100 690	100 690	100 690	2	0 - 3.00 0 - 76.2	1° 0'
	150 1035	150 1035	150 1035	2	0 - 3.00 0 - 76.2	1° 0'
	200 1375	200 1375	200 1375	3	0 - 2.00 0 - 50.8	0° 30'
	300 2065	300 2065	300 2065	3	0 - 2.00 0 - 50.8	0° 30'
120 3000	75 515	75 515	75 515	2	0 - 3.00 0 - 76.2	1° 0'
	125 860	125 860	125 860	2	0 - 3.00 0 - 76.2	1° 0'
	200 1375	200 1375	200 1375	3	0 - 2.00 0 - 50.8	0° 30'
	250 1725	250 1725	250 1725	3	0 - 2.00 0 - 50.8	0° 30'
144 3600	75 515	75 515	75 515	2	0 - 3.00 0 - 76.2	1° 0'
	100 690	100 690	100 690	2	0 - 3.00 0 - 76.2	1° 0'
	150 1035	150 1035	150 1035	3	0 - 2.00 0 - 50.8	0° 30'
	200 1375	200 1375	200 1375	3	0 - 2.00 0 - 50.8	0° 30'

(1) For allowable test or transient pressure, the maximum working pressure may be increased to 1½ times the values shown.

(2) Style 230 couplings provide ½"/15 mm of axial movement within the published pipe end separation range and are not designed for use as an expansion coupling.

(3) Published deflection values are intended for installation only. Allowable in-service or dynamic deflection is limited by the maximum allowable axial movement at the joint. Contact Victaulic for details.

## Style 230 Non-Restrained Flexible Coupling

### CLOSURE TOOLS



MANUAL TOOL



HYDRAULIC TOOL

#### Manual Tools

- CTM-01: for use on 5" and 8" body widths
- CTM-02: for use on 10" body widths  
for use on 12" body widths with thickness of  $\frac{3}{16}$ " or less

#### Hydraulic Tools

- CTH-01\*: for use on 12" body widths with thickness of  $\frac{1}{4}$ " or greater  
for use on 14", 16" and 18" body widths
- CTH-02: for use on all type 3 couplings

- Hydraulic tool package comes standard with:

- one (1) tool head
- one (1) hydraulic cylinder
- one (1) hydraulic hose
- one (1) hand pump

\* A CTH-01 hydraulic closure tool can be used in applications where the CTM-02 manual closure tool is recommended.

Note: The closure tools listed above are designed specifically for Victaulic Style 230, 231, 232 and 233 couplings. If ordering custom product, contact Victaulic for appropriate tool selection.

# Style 230 Non-Restrained Flexible Coupling

**PRODUCT CONFIGURATOR**

**C 0230 0144 50 S 2 D E P S 00**

Class	Style	Actual Pipe O.D.*		Body Type	Segments	PSI/kPa Rating	Rubber Compound	Paint	Hardware	Options
		Inches <sup>^</sup>	Fraction							
C	0230	0007 through 0150	00 - 0 13 - 1/8 25 - 1/4 38 - 3/8 50 - 1/2 63 - 5/8 75 - 3/4 88 - 7/8	S - Carbon	1 - One 2 - Two	B - 50/345 C - 75/515 D - 100/690 E - 125/860 F - 150/1035 G - 175/1200 H - 200/1375 J - 250/1725 K - 300/2065 L - 350/2410 M - 400/2750	E - EPDM I - Isoprene L - Silicone T - Nitrile V - Neoprene O - Fluoro-elastomer	F - Fusion bonded epoxy P - Orange enamel T - Shop primer B - Liquid epoxy N - Fusion bonded nylon G - Galvanized 0 - None	S - Carbon X - Stainless	00 - None 01 - Pipe Stops

<sup>^</sup> Couplings are available in a range of nominal sizes from 8 - 144". For systems above 144" contact Victaulic for details.  
 \* For actual pipe O.D. round down to the nearest 1/8" to determine proper coupling size required.

**ENGINEERED PRODUCTS OPTIONS**

For non-standard products the Victaulic Engineered Products group can assist with specialty joints designed to meet the specific size, pressure and temperature requirements of your system. The Engineered Products group will also provide pricing and availability for options such as pipe stops and insulating sleeves.

**WARRANTY**

Refer to the Warranty section of the current Price List or contact Victaulic for details.

**NOTE**

This product shall be manufactured by Victaulic or to Victaulic specifications. All products to be installed in accordance with current Victaulic installation/assembly instructions. Victaulic reserves the right to change product specifications, designs and standard equipment without notice and without incurring obligations.

**TESTING**

Victaulic Style 230 couplings are designed to allow for a 50 percent increase over the published maximum working pressure for test and/or transient pressures. Due to the huge volume of air that can be involved in jobsite air testing and the nature of air or gas that is pressurized, jobsite air testing should be limited to 25 psi/175 kPa or less.

For complete contact information, visit [www.victaulic.com](http://www.victaulic.com)

60.01 3362 REV K UPDATED 06/2022

VICTAULIC IS A REGISTERED TRADEMARK OF VICTAULIC COMPANY. © 2013 VICTAULIC COMPANY. ALL RIGHTS RESERVED.

