

Style 233 Restrained Flexible Coupling For Dynamic Joint Deflection

Victaulic Bolted Split-Sleeve Products (VBSP) Style 233 carbon steel restrained couplings (formerly Depend-O-Lok FxF Modified) provide a fully restrained, flexible pipe joint that satisfies the requirements set forth by the AWWA C227 Standard for Bolted, Split-Sleeve Restrained and Non-Restrained Couplings for Plain-End Pipe.

This style of coupling is typically used in buried or exposed pipe applications for field joint connections where joint flexibility and thrust restraint is required. Style 233 couplings are designed to allow for dynamic (in-service) joint deflection and are most commonly used in pairs outside of a structure to accommodate differential settlement between the structure and the pipeline. The Style 233 couplings can also allow for up to 1/25 mm of axial pipe movement at the joint due to thermal pipe movement. Typical applications include water and wastewater treatment pipelines, force main and water transmission piping, and buried piping connections outside of valve vaults or other structures (when couplings are used in pairs at a minimum). The couplings provide ease of installation and come standard with an epoxy coating for protection against corrosion. The use of a heat-shrink sleeve or tape system can be used with minimal effort due to the low profile configuration.

The dual-arched mechanical coupling body houses the o-ring gaskets that provide a radial seal around the circumference of the pipe, while a sealing plate provides for the axial seal across the coupling body and pipe joint. The Style 233 coupling incorporates a restraint ring welded to each pipe end (furnished with the coupling), allowing the coupling housing to straddle the restraint rings and confining the rings under the coupling body in order to prevent joint separation. The coupling housing and restraint ring welds are designed to accommodate hoop stress and end loads to meet system pressure requirements. Style 233 restrained couplings also perform at negative pipe pressures up to full vacuum. The o-ring gasket is not pressure responsive and therefore does not require internal pipe pressure to assist with the seal. The arched cross-sectional design provides stiffness to resist forces encountered during negative pressure (submerged) or vacuum service.

Style 233 couplings are available in standard nominal sizes from 8 – 144"/200 – 3600 mm, with other sizes available based on design and application requirements. The Style 233 restrained coupling can accommodate operating pressures up to 300 psi/2065 kPa (with higher pressure available) depending on the actual pipe diameter and wall thickness. For pressures and sizes not shown in the dimension and performance tables contact Victaulic for information on our engineered products by visiting our web site.

All flexible mechanical couplings should be properly supported to minimize or eliminate undesirable loads at the joint. Pipe support requirements are defined within the Victaulic Application Guidelines document. Please see publication 26.20.

For proper closure tool selection see column marked Tool Type on pages 6-8.



8 – 144"/200 – 3600mm

JOB/OWNER

System No. _____

Location _____

CONTRACTOR

Submitted By _____

Date _____

ENGINEER

Spec Sect _____ Para _____

Approved _____

Date _____

www.victaulic.com

VICTAULIC IS A REGISTERED TRADEMARK OF VICTAULIC COMPANY. © 2022 VICTAULIC COMPANY. ALL RIGHTS RESERVED.

REV_L



Style 233 Restrained Flexible Coupling For Dynamic Joint Deflection

PRODUCT GUIDE

Product Style Guide			
Submittal Number	Style Number	Coupling/Body Material	Application
60.01	230	Carbon Steel	Non-Restrained Coupling
60.02	230S	Stainless Steel	Non-Restrained Coupling
60.03	231	Carbon Steel	Expansion Coupling
60.04	231S	Stainless Steel	Expansion Coupling
60.05	232	Carbon Steel	Restrained Coupling
60.06	232S	Stainless Steel	Restrained Coupling
60.07	233	Carbon Steel	Restrained Coupling For Dynamic Joint Deflection
60.08	233S	Stainless Steel	Restrained Coupling For Dynamic Joint Deflection
60.09	234	Carbon Steel	Restrained Single-Gasket Coupling
60.10	234S	Stainless Steel	Restrained Single-Gasket Coupling

SEGMENTED COUPLINGS

The Style 233 dimension tables list the minimum number of coupling housing segments for a particular pipe size. For special applications, restrained couplings are available in two (or more) segments to allow for installation of the coupling over an existing pipe joint or to facilitate ease of handling for larger size couplings. The o-ring gaskets (except Silicone) can be furnished “split” to allow for field bonding when an existing pipe joint configuration does not allow for installation of a complete o-ring onto the pipe end.

Style 233 Restrained Flexible Coupling For Dynamic Joint Deflection

BODY TYPE

Cross-Section

NOTE: Body type is not optional and will be determined by system requirements.

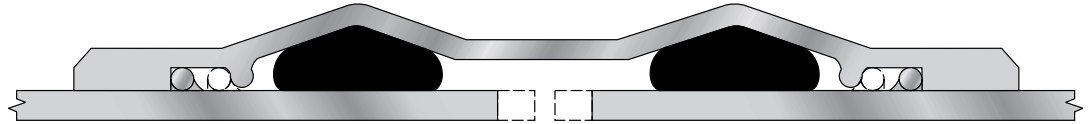

Type 2 coupling is a shouldered coupling. This is a heavy duty coupling to accommodate higher pressures for certain pipe diameters. The shoulders welded to the edge of the coupling body provide a vertical bearing surface for the restraint rings and provide additional cross-sectional stiffness. The limit rings on the inside of the coupling body ensure that any axial movement or dynamic joint deflection is distributed across the coupling between both sides of the joint.

COUPLING COMPONENTS

1. **Body** – Dual arch cross-section.
2. **Shoulders** – Provide additional stiffness, allow for larger o-ring gasket and provide vertical bearing surface for restraint rings.
3. **Closure Plates** – Low profile bolt pads for installation and tightening of coupling; gap between plates of installed coupling allows for field flexibility.
4. **Sealing Plate** – Provides axial seal across the coupling body and pipe joint.
5. **O-ring Gaskets** – Provide circumferential seal.
6. **Fasteners**
 - Studs – High Strength Threaded Rod
 - Nuts – Heavy Hex Nuts
 - Washers – SAE small pattern flat washers
7. **Restraint Rings** – Attached to pipe ends to create a restrained joint.

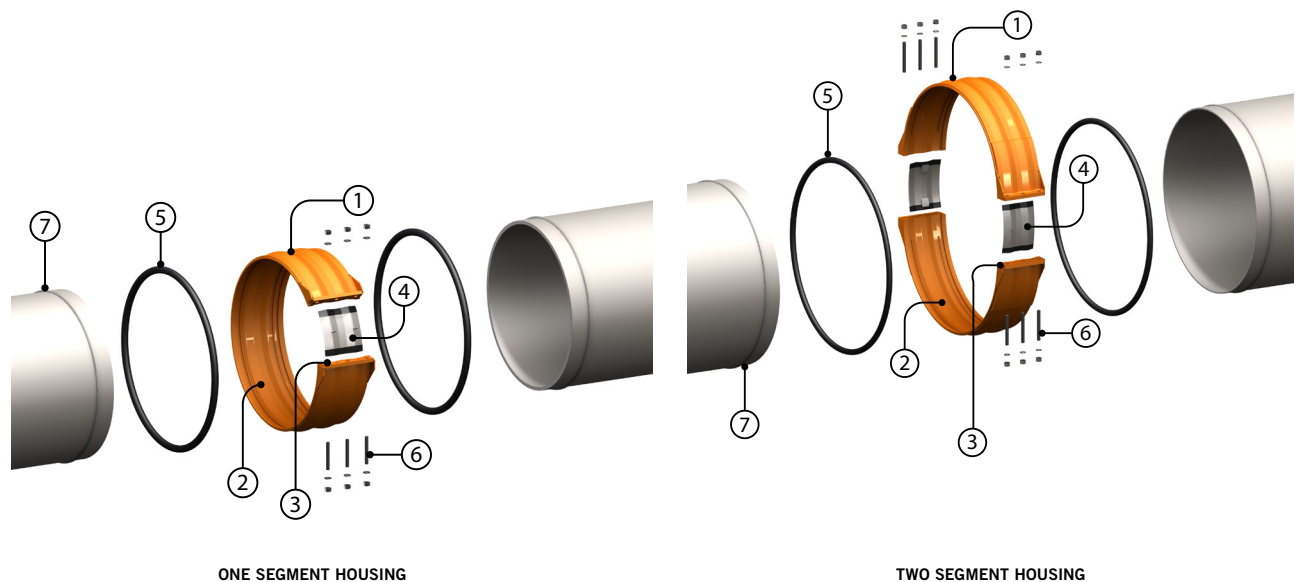

Style 233 Restrained Flexible Coupling For Dynamic Joint Deflection

MATERIAL SPECIFICATIONS

Body

Carbon Steel conforming to ASTM A36 or ASTM A1011 (for gauge thicknesses)

Shoulders

Carbon Steel conforming to ASTM A36

Closure Plates

Carbon Steel conforming to ASTM A36

Sealing Plate

Stainless Steel conforming to ASTM A240 316L

O-ring Gaskets

Standard (Specify choice on order):

- **EPDM** -30°F to +230°F/-34°C to +110°C
Cold and hot water within allowable temperature range; dilute acids; excellent resistance to the deteriorative effects of ozone, oxygen, heat and most chemicals not involving hydrocarbons. NOT RECOMMENDED FOR PETROLEUM SERVICES.
- **Silicone** -30°F to +350°F/-34°C to +177°C
Dry, hot air applications; excellent resistance to many chemicals. NOT RECOMMENDED FOR HOT WATER OR STEAM APPLICATIONS.
- **Isoprene** -40°F to +160°F/-40°C to +71°C
Water; salt water; sewage; good resistance to oxygen and dilute acids

Services listed are general service recommendations only. Refer to a chemical elastomer guide for specific applications and suitability of gasket material for services that are not listed.

Optional gasket (specify choice on order):

- **Nitrile** -20°F to +180°F/-28°C to +82°C
Water; petroleum products, vegetable and mineral oils; air with oil vapors within allowable temperature range; good resistance to hydrocarbons; acids and bases.
- **Fluoroelastomer** +20°F to +300°F/-7°C to +149°C
Outstanding resistance to heat and most chemicals.
- **Neoprene** -30°F to +180°F/-34°C to +82°C
Water and wastewater; good resistance to ozone, effects of UV and some oils.

Restraint Rings

Carbon Steel conforming to ASTM A108 Grade 1018

Fasteners

Studs - Carbon Steel conforming to ASTM A193 Grade B7 zinc plated.

Optional: Stainless Steel conforming to ASTM A193 Grade B8M 316 Class 2

Nuts - Heavy hex nuts

Carbon Steel conforming to ASTM A194 Grade 2H zinc plated

Optional: Stainless Steel conforming to ASTM A194 Grade 8M 316

Washers - Carbon Steel SAE small pattern flat washers conforming to ASTM F436 SAE pattern zinc plated

Optional: Stainless Steel Type 316 SAE pattern.

Style 233 Restrained Flexible Coupling For Dynamic Joint Deflection

LININGS AND COATINGS

Standard (specify choice on order):

- Liquid Epoxy:**
 Liquid epoxy is applied per AWWA C210, 16 mils minimum DFT and is NSF61 approved. Epoxy can be applied as a primer for field applied top coat where UV protection due to sunlight exposure is required. This coating offers excellent corrosion protection for buried applications. A supplemental corrosion protection system such as heat shrink sleeve or tape coat system is recommended for buried applications.
- Fusion Bonded Epoxy:**
 Fusion bonded epoxy is applied with an electrostatic spray system using a long cure epoxy powder that offers excellent chemical resistance and corrosion protection. Fusion bonded epoxy is applied per AWWA C213, 12 mils minimum DFT and is NSF61 approved.

Optional (specify choice on order):

- Phenolic Alkyd Primer:**
 Phenolic Alkyd primer is a lead-free and chromate-free, fast-drying, corrosion-resistant primer that accepts a variety of high-performance topcoats, but is not recommended for immersion service by itself. This primer system is typically applied at 2 to 3 mils DFT.
- Other Coating Systems (Available Upon Request):**
 A water based enamel coating is available. This paint offers an aesthetic coating for minimal protection, short-term installations or where corrosion protection is not a consideration. Fusion bonded nylon for chemical and abrasion resistance, as well as other coatings such as organic zinc primers and hot dipped galvanizing may also be available.

PIPE END DIMENSIONAL TOLERANCE AND OVALITY

For specific pipe diameter tolerances, pipe ovality (roundness) requirements and minimum/maximum pipe diameter allowance, refer to the tables included in the Installation Manuals (below) and 26.20 Application Guidelines.

I-233.S1 - Styles 233/233S Restrained Flexible Coupling For Dynamic Joint Deflection (Type 2, One-Segment)

I-233.S2 - Styles 233/233S Restrained Flexible Coupling For Dynamic Joint Deflection (Type 2, Two-Segments)

Style 233 Restrained Flexible Coupling For Dynamic Joint Deflection

DIMENSIONS

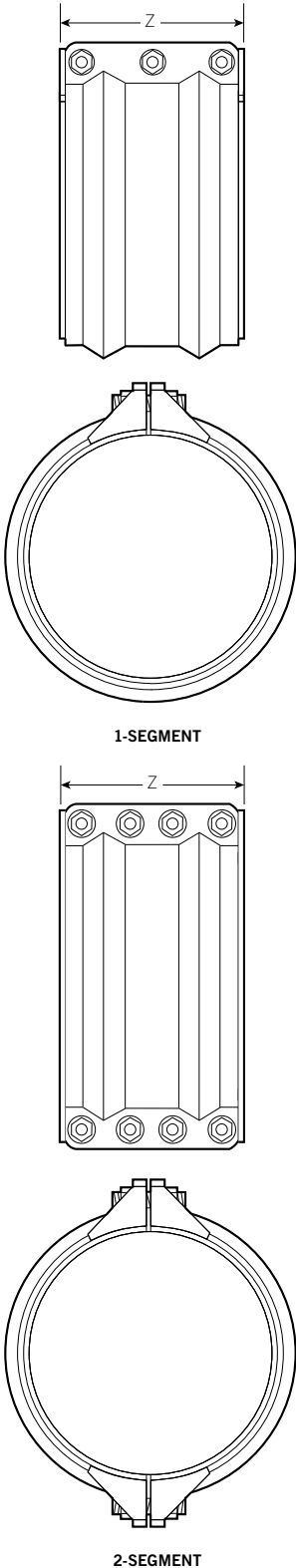

(1)	(2)	(3)	Coupling Dimensions		(4)	(5)	(6)	Body Type	Tool Type
			Body Thickness In.	Width (Z) In./mm					
8 200	7.00 - 8.88 177.8 - 225.6	300 2065	11 ga.	12.50 317.5	1	3 - 3/4 x 6 38 17	2	B,C	
10 250	9.00 - 10.88 228.6 - 276.4	300 2065	10 ga.	12.50 317.5	1	3 - 3/4 x 6 45 20	2	B,C	
12 300	11.00 - 12.88 279.4 - 327.2	200 1375	10 ga.	12.50 317.5	1	3 - 3/4 x 6 51 23	2	B,C	
		300 2065	3/16	12.50 317.5	1	3 - 3/4 x 6 53 24	2	B,C	
14 350	13.00 - 14.88 330.2 - 378.0	200 1375	10 ga.	12.50 317.5	1	3 - 3/4 x 6 56 25	2	B,C	
		300 2065	3/16	12.50 317.5	1	3 - 3/4 x 6 60 27	2	B,C	
16 400	15.00 - 16.88 381.0 - 428.8	200 1375	3/16	12.50 317.5	1	3 - 3/4 x 6 69 31	2	B,C	
		300 2065	1/4	12.50 317.5	1	3 - 3/4 x 6 91 41	2	C	
18 450	17.00 - 18.88 431.8 - 479.6	200 1375	3/16	12.50 317.5	1	3 - 3/4 x 6 76 34	2	B,C	
		300 2065	1/4	12.50 317.5	1	3 - 3/4 x 6 99 45	2	C	
20 500	19.00 - 21.88 482.6 - 555.8	200 1375	3/16	12.50 317.5	1	3 - 3/4 x 6 82 37	2	B,C	
		300 2065	1/4	12.50 317.5	1	3 - 3/4 x 6 109 49	2	C	
24 600	22.00 - 26.88 558.8 - 682.8	150 1035	3/16	12.50 317.5	1	3 - 3/4 x 6 97 44	2	B,C	
		250 1725	1/4	12.50 317.5	1	3 - 3/4 x 6 130 59	2	C	
		300 2065	3/8	12.50 317.5	2	6 - 7/8 x 8 250 113	2	C	
30 750	27.00 - 32.88 685.8 - 835.2	100 690	3/16	12.50 317.5	1	3 - 3/4 x 6 118 54	2	B,C	
		200 1375	1/4	12.50 317.5	1	3 - 3/4 x 6 158 72	2	C	
		300 2065	3/8	12.50 317.5	2	6 - 7/8 x 8 297 135	2	C	
36 900	33.00 - 38.88 838.2 - 987.6	150 1035	1/4	12.50 317.5	1	3 - 3/4 x 6 187 85	2	C	
		250 1725	3/8	12.50 317.5	2	6 - 7/8 x 8 343 156	2	C	
		300 2065	1/2	14.75 374.7	2	8 - 1 x 8 543 246	2	C	
42 1050	39.00 - 44.88 990.6 - 1140.0	150 1035	1/4	12.50 317.5	1	3 - 3/4 x 6 215 98	2	C	
		200 1375	3/8	12.50 317.5	2	6 - 7/8 x 8 390 177	2	C	
		300 2065	1/2	14.75 374.7	2	8 - 1 x 8 617 280	2	C	

(1) Couplings must be used on pipe with a minimum wall thickness that meets the requirements of AWWA C200 for carbon steel pipe.
 (2) Actual pipe O.D. required at time of order. For actual pipe O.D. round down to the nearest 1/8" to determine proper coupling size required.
 (3) For allowable test or transient pressure, the maximum working pressure may be increased to 1 1/2 times the values shown.
 (4) 1-segment couplings may be available as 2-segment couplings to allow for in-place pipe installations. Contact Victaulic for details.
 (5) Coupling weights are based on nominal pipe diameter and include all accessories. Weight may vary based on actual size of pipe.
 (6) Closure Tool Recommendations:
 B= CTM-02 Large Manual Closure Tool
 C= CTH-01 10-Ton Hydraulic Closure Tool
 *For more details on closure tools refer to page 15.
 Note: The data in this table only applies when carbon steel couplings are being used on carbon steel pipe.

Style 233 Restrained Flexible Coupling For Dynamic Joint Deflection

DIMENSIONS

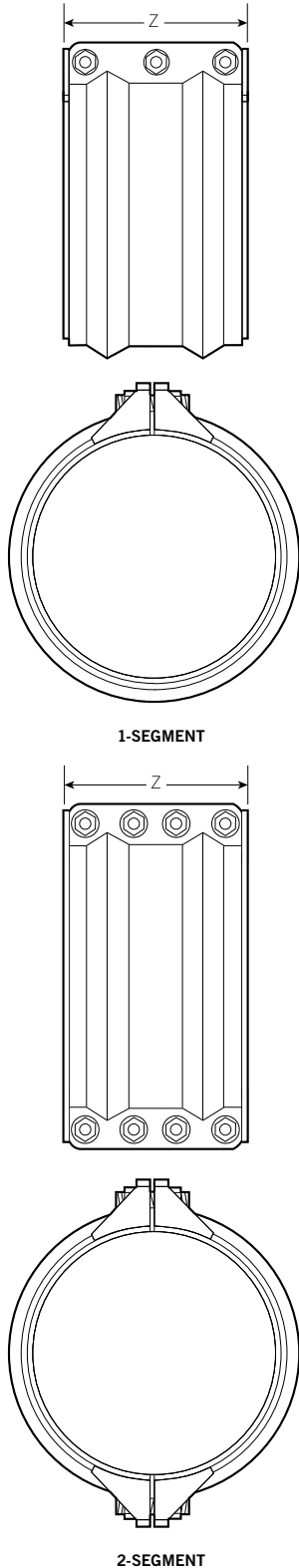

(1) Nominal Pipe Size In./mm	(2) Actual Pipe O.D. Range In./mm	(3) Maximum Working Pressure psi/kPa	Coupling Dimensions		(4) Min. No. of Coupling Segments	No. of Fasteners - Fastener Dimensions Dia. x Length In. x In.	(5) Approximate Weight Each Lbs/Kg.	Body Type	(6) Tool Type
			Body Thickness In.	Width (Z) In./mm					
48 1200	45.00 - 50.88 1143.0 - 1292.4	100 690	¼	12.50 317.5	1	3 - ¾ x 6	242 110	2	C
		150 1035	⅜	12.50 317.5	2	6 - ⅞ x 8	435 197	2	C
		250 1725	½	14.75 374.7	2	8 - 1 x 8	690 313	2	C
		300 2065	⅝	15.00 381.0	2	8 - 1 x 8	859 390	2	C
54 1350	51.00 - 56.88 1295.4 - 1444.8	150 1035	⅜	12.50 317.5	2	6 - ⅞ x 8	472 214	2	C
		200 1375	½	14.75 374.7	2	8 - 1 x 8	763 346	2	C
		250 1725	⅝	15.00 381.0	2	8 - 1 x 8	951 431	2	C
60 1500	57.00 - 62.88 1447.8 - 1597.2	150 1035	⅜	12.50 317.5	2	6 - ⅞ x 8	518 235	2	C
		200 1375	½	14.75 374.7	2	8 - 1 x 8	837 380	2	C
		250 1725	⅝	15.00 381.0	2	8 - 1 x 8	1042 473	2	C
66 1650	63.00 - 68.88 1600.2 - 1749.6	100 690	⅜	12.50 317.5	2	6 - ⅞ x 8	554 251	2	C
		150 1035	½	14.75 374.7	2	8 - 1 x 8	893 405	2	C
		200 1375	⅝	15.00 381.0	2	8 - 1 x 8	1133 514	2	C
72 1800	69.00 - 74.88 1752.6 - 1902.0	100 690	⅜	12.50 317.5	2	6 - ⅞ x 8	601 273	2	C
		150 1035	½	14.75 374.7	2	8 - 1 x 8	967 439	2	C
		200 1375	⅝	15.00 381.0	2	8 - 1 x 8	1224 555	2	C
78 1950	75.00 - 80.88 1905.0 - 2054.4	100 690	⅜	12.50 317.5	2	6 - ⅞ x 8	637 289	2	C
		150 1035	½	14.75 374.7	2	8 - 1 x 8	1039 471	2	C
		175 1200	⅝	15.00 381.0	2	8 - 1 x 8	1315 596	2	C
84 2100	81.00 - 86.88 2057.0 - 2207.0	100 690	⅜	12.50 317.5	2	6 - ⅞ x 8	684 310	2	C
		150 1035	½	14.75 374.7	2	8 - 1 x 8	1097 498	2	C
		175 1200	⅝	15.00 381.0	2	8 - 1 x 8	1387 629	2	C
90 2250	87.00 - 92.88 2209.8 - 2359.2	100 690	⅜	12.50 317.5	2	6 - ⅞ x 8	719 326	2	C
		125 860	½	14.75 374.7	2	8 - 1 x 8	1154 523	2	C
		150 1035	⅝	15.00 381.0	2	8 - 1 x 8	1478 670	2	C

- (1) Couplings must be used on pipe with a minimum wall thickness that meets the requirements of AWWA C200 for carbon steel pipe.
 - (2) Actual pipe O.D. required at time of order. For actual pipe O.D. round down to the nearest ⅛" to determine proper coupling size required.
 - (3) For allowable test or transient pressure, the maximum working pressure may be increased to 1½ times the values shown.
 - (4) 1-segment couplings may be available as 2-segment couplings to allow for in-place pipe installations. Contact Victaulic for details.
 - (5) Coupling weights are based on nominal pipe diameter and include all accessories. Weight may vary based on actual size of pipe.
 - (6) Closure Tool Recommendations: *
 B= CTM-Q2 Large Manual Closure Tool
 C= CTH-01 10-Ton Hydraulic Closure Tool
- *For more details on closure tools refer to page 15.
 Note: The data in this table only applies when carbon steel couplings are being used on carbon steel pipe.

Style 233 Restrained Flexible Coupling For Dynamic Joint Deflection

DIMENSIONS

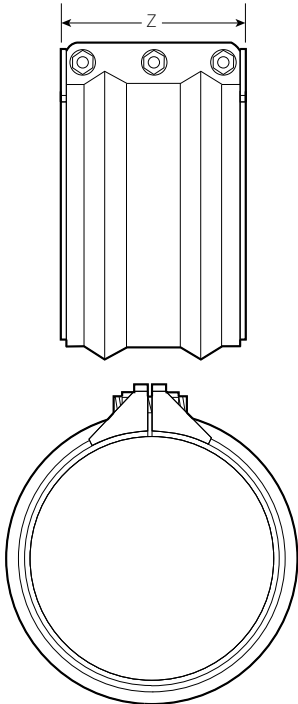

1-SEGMENT

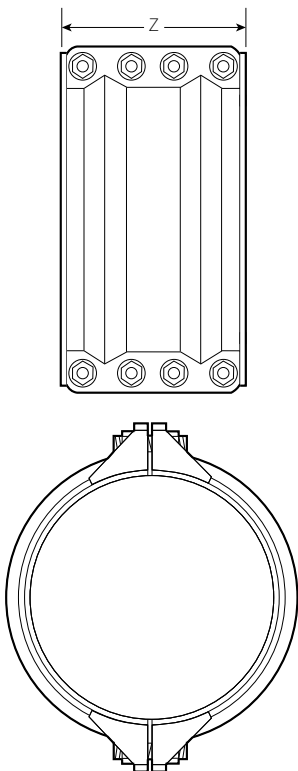

2-SEGMENT

(1) Nominal Pipe Size In./mm	(2) Actual Pipe O.D. Range In./mm	(3) Maximum Working Pressure psi/kPa	Coupling Dimensions		(4) Min. No. of Coupling Segments	No. of Fasteners - Fastener Dimensions Dia. x Length In. x In.	(5) Approximate Weight Each Lbs/Kg.	Body Type	(6) Tool Type
			Body Thickness In.	Width (Z) In./mm					
96 2400	93.00 - 101.88 2362.2 - 2587.8	100 690	3/8	12.50 317.5	2	6 - 7/8 x 8	775 352	2	C
		125 860	1/2	14.75 374.7	2	8 - 1 x 8	1241 563	2	C
		150 1035	5/8	15.00 381.0	2	8 - 1 x 8	1587 720	2	C
108 2700	102.00 - 113.88 2590.8 - 2892.6	75 515	3/8	12.50 317.5	2	6 - 7/8 x 8	846 384	2	C
		100 690	1/2	14.75 374.7	2	8 - 1 x 8	1371 622	2	C
		125 860	5/8	15.00 381.0	2	8 - 1 x 8	1750 1130.8	2	C
120 3000	114.00 - 125.88 2895.6 - 3197.4	75 515	3/8	12.50 317.5	2	6 - 7/8 x 8	929 421	2	C
		100 690	1/2	14.75 374.7	2	8 - 1 x 8	1502 681	2	C
		125 860	5/8	15.00 381.0	2	8 - 1 x 8	1912 867	2	C
144 3600	126.00 - 150.00 3200.4 - 3810.0	50 345	3/8	12.50 317.5	2	6 - 7/8 x 8	1073 487	2	C
		75 515	1/2	14.75 374.7	2	8 - 1 x 8	1746 792	2	C
		100 690	5/8	15.00 381.0	2	8 - 1 x 8	2238 1015	2	C

- (1) Couplings must be used on pipe with a minimum wall thickness that meets the requirements of AWWA C200 for carbon steel pipe.
 - (2) Actual pipe O.D. required at time of order. For actual pipe O.D. round down to the nearest 1/8" to determine proper coupling size required.
 - (3) For allowable test or transient pressure, the maximum working pressure may be increased to 1 1/2 times the values shown.
 - (4) 1-segment couplings may be available as 2-segment couplings to allow for in-place pipe installations. Contact Victaulic for details.
 - (5) Coupling weights are based on nominal pipe diameter and include all accessories. Weight may vary based on actual size of pipe.
 - (6) Closure Tool Recommendations:
 - B= CTM-02 Large Manual Closure Tool
 - C= CTH-01 10-Ton Hydraulic Closure Tool
- *For more details on closure tools refer to page 15.
 Note: The data in this table only applies when carbon steel couplings are being used on carbon steel pipe.

Style 233 Restrained Flexible Coupling For Dynamic Joint Deflection

PERFORMANCE

Nominal Pipe Size In./mm	(1)			Body Type	(2) (3) Pipe End Separation Min - Max In./mm	(3) (4) Max. Allow. Deflection Degrees	(5) Max. Permissible End Load lbf/N
	Maximum Working Pressure psi/kPa Carbon Steel	Maximum Working Pressure psi/kPa Stainless Steel	Maximum Working Pressure psi/kPa Ductile Iron				
8 200	300 2065	300 2065	300 2065	2	0.50 - 1.50 12.7 - 38.1	4° 0'	15079 67075
10 250	300 2065	300 2065	300 2065	2	0.50 - 1.50 12.7 - 38.1	3° 30'	23561 104805
12 300	200 1375	200 1375	200 1375	2	0.50 - 1.50 12.7 - 38.1	3° 15'	22619 100614
	300 2065	300 2065	250 1725	2	0.50 - 1.50 12.7 - 38.1	3° 15'	33929 150924
14 350	200 1375	200 1375	200 1375	2	0.50 - 1.50 12.7 - 38.1	3° 0'	30787 136947
	300 2065	300 2065	250 1725	2	0.50 - 1.50 12.7 - 38.1	3° 0'	46181 205423
16 400	200 1375	200 1375	200 1375	2	0.50 - 1.50 12.7 - 38.1	3° 0'	40212 178872
	300 2065	300 2065	300 2065	2	0.50 - 1.50 12.7 - 38.1	3° 0'	60318 268308
18 450	200 1375	200 1375	175 1200	2	0.50 - 1.50 12.7 - 38.1	3° 0'	50893 226383
	300 2065	300 2065	250 1725	2	0.50 - 1.50 12.7 - 38.1	3° 0'	76340 339577
20 500	200 1375	200 1375	150 1035	2	0.50 - 1.50 12.7 - 38.1	2° 30'	62831 279486
	300 2065	300 2065	250 1725	2	0.50 - 1.50 12.7 - 38.1	2° 30'	94247 419232
24 600	150 1035	150 1035	125 860	2	0.50 - 1.50 12.7 - 38.1	2° 0'	67858 301847
	250 1725	250 1725	200 1375	2	0.50 - 1.50 12.7 - 38.1	2° 0'	113097 503081
	300 2065	250 1725	200 1375	2	0.50 - 1.50 12.7 - 38.1	2° 0'	135716 603695
30 750	100 690	100 690	100 690	2	0.50 - 1.50 12.7 - 38.1	1° 45'	70685 314423
	200 1375	200 1375	150 1035	2	0.50 - 1.50 12.7 - 38.1	1° 45'	141371 628850
	300 2065	200 2065	150 1035	2	0.50 - 1.50 12.7 - 38.1	1° 45'	212057 943277
36 900	150 1035	150 1035	125 860	2	0.50 - 1.50 12.7 - 38.1	1° 30'	152681 679159
	250 1725	175 1200	125 860	2	0.50 - 1.50 12.7 - 38.1	1° 30'	254469 1131935
	300 2065	200 1375	175 1200	2	1.00 - 2.00 25.4 - 50.8	1° 30'	305362 1358318
42 1050	150 1035	150 1035	125 860	2	0.50 - 1.50 12.7 - 38.1	1° 15'	207816 924412
	200 1375	150 1035	125 860	2	0.50 - 1.50 12.7 - 38.1	1° 15'	277088 1232549
	300 2065	200 1375	150 1035	3	1.00 - 2.00 25.4 - 50.8	1° 15'	415632 1848823
48 1200	100 690	100 690	100 690	2	0.50 - 1.50 12.7 - 38.1	1° 7'	180955 804928
	150 1035	150 1035	100 690	2	0.50 - 1.50 12.7 - 38.1	1° 7'	271433 1207394
	250 1725	176 1200	125 860	2	1.00 - 2.00 25.4 - 50.8	1° 7'	452389 2012327
	300 2065	200 1375	175 1200	2	1.00 - 2.00 25.4 - 50.8	1° 7'	542867 2414793

- (1) For allowable test or transient pressure, the maximum working pressure may be increased to 1½ times the values shown.
- (2) Maximum allowable axial pipe movement at the joint is the difference between the maximum and minimum pipe end separation. At maximum pipe end separation, axial movement can only occur via pipe expansion into the joint and vice versa.
- (3) Pipe end movement and deflection are non-concurrent.
- (4) Published deflection values are intended and available for both static (installed) and dynamic (in-service) joint deflection. The coupling closure should be located 90 degrees from the direction of joint deflection.
- (5) The maximum permissible end loads listed in the table are calculated using the nominal pipe OD. The actual maximum permissible end load will be less or greater than the published figures depending on the actual pipe OD.

Style 233 Restrained Flexible Coupling For Dynamic Joint Deflection

PERFORMANCE

Nominal Pipe Size In./mm	(1)			Body Type	(2) (3)	(3) (4)	(5)
	Maximum Working Pressure psi/kPa Carbon Steel	Maximum Working Pressure psi/kPa Stainless Steel	Maximum Working Pressure psi/kPa Ductile Iron		Pipe End Separation Min - Max In./mm	Max. Allow. Deflection Degrees	Max. Permissible End Load lbf/N
54 1350	150 1035	100 690	75 515	2	0.50 - 1.50 12.7 - 38.1	1° 0'	343533 1528111
	200 1375	150 1035	125 1035	2	1.00 - 2.00 25.4 - 50.8	1° 0'	458044 2037481
	250 1725	200 1375	150 1375	2	1.00 - 2.00 25.4 - 50.8	1° 0'	572555 2546852
60 1500	150 1035	100 690	75 515	2	0.50 - 1.50 12.7 - 38.1	0° 54'	424115 1886558
	200 1375	125 860	100 690	2	1.00 - 2.00 25.4 - 50.8	0° 54'	565486 2515407
	250 1725	175 1200	125 860	2	1.00 - 2.00 25.4 - 50.8	0° 54'	706858 3144261
66 1650	100 690	100 690	75 515	2	0.50 - 1.50 12.7 - 38.1	0° 49'	342119 1521821
	150 1035	125 860	100 690	2	1.00 - 2.00 25.4 - 50.8	0° 49'	513179 2282734
	200 1375	150 1035	125 860	2	1.00 - 2.00 25.4 - 50.8	0° 49'	684238 3043643
72 1800	100 690	75 515	75 515	2	0.50 - 1.50 12.7 - 38.1	0° 45'	407150 1811094
	150 1035	125 860	100 690	2	1.00 - 2.00 25.4 - 50.8	0° 45'	610725 2716640
	200 1375	150 1375	125 860	2	1.00 - 2.00 25.4 - 50.8	0° 45'	814300 3622187
78 1950	100 690	75 515	50 345	2	0.50 - 1.50 12.7 - 38.1	0° 42'	477836 2125521
	150 1035	100 690	75 515	2	1.00 - 2.00 25.4 - 50.8	0° 42'	716754 3188281
	175 1200	125 860	100 690	3	1.00 - 2.00 25.4 - 50.8	0° 42'	836213 3719661
84 2100	100 690	75 515	50 345	2	0.50 - 1.50 12.7 - 38.1	0° 39'	554176 2465098
	150 1035	100 690	75 515	2	1.00 - 2.00 25.4 - 50.8	0° 39'	831265 3697651
	175 1200	125 860	100 690	2	1.00 - 2.00 25.4 - 50.8	0° 39'	969809 4313926
90 2250	100 690	75 515	50 345	2	0.50 - 1.50 12.7 - 38.1	0° 36'	636172 2829834
	125 860	100 690	75 515	2	1.00 - 2.00 25.4 - 50.8	0° 36'	795215 3537293
	150 1035	125 860	100 690	2	1.00 - 2.00 25.4 - 50.8	0° 36'	954258 4244751

- (1) For allowable test or transient pressure, the maximum working pressure may be increased to 1½ times the values shown.
- (2) Maximum allowable axial pipe movement at the joint is the difference between the maximum and minimum pipe end separation. At maximum pipe end separation, axial movement can only occur via pipe expansion into the joint and vice versa.
- (3) Pipe end movement and deflection are non-concurrent.
- (4) Published deflection values are intended and available for both static (installed) and dynamic (in-service) joint deflection. The coupling closure should be located 90 degrees from the direction of joint deflection.
- (5) The maximum permissible end loads listed in the table are calculated using the nominal pipe OD. The actual maximum permissible end load will be less or greater than the published figures depending on the actual pipe OD.

Style 233 Restrained Flexible Coupling For Dynamic Joint Deflection

PERFORMANCE

Nominal Pipe Size In./mm	(1)			Body Type	(2) (3) Pipe End Separation Min - Max In./mm	(3) (4) Max. Allow. Deflection Degrees	(5) Max. Permissible End Load lbf/N
	Maximum Working Pressure psi/kPa Carbon Steel	Maximum Working Pressure psi/kPa Stainless Steel	Maximum Working Pressure psi/kPa Ductile Iron				
96 2400	100 690	50 345	50 345	2	0.50 - 1.50 12.7 - 38.1	0° 33'	723822 3219721
	125 860	75 515	50 345	2	1.00 - 2.00 25.4 - 50.8	0° 33'	904778 4024653
	150 1035	100 1035	75 515	2	1.00 - 2.00 25.4 - 50.8	0° 33'	1085734 4829586
108 2700	75 515	50 345	25 170	2	0.50 - 1.50 12.7 - 38.1	0° 30'	687066 3056222
	100 690	75 515	50 345	2	1.00 - 2.00 25.4 - 50.8	0° 30'	916088 4074963
	125 860	100 690	75 515	2	1.00 - 2.00 25.4 - 50.8	0° 30'	1145110 5093703
120 3000	75 515	50 345	25 170	2	0.50 - 1.50 12.7 - 38.1	0° 27'	848230 3773115
	100 690	50 345	50 345	2	1.00 - 2.00 25.4 - 50.8	0° 27'	1130973 5030819
	125 860	75 515	50 345	3	1.00 - 2.00 25.4 - 50.8	0° 27'	1413716 6288523
144 3600	50 345	25 170	25 170	2	0.50 - 1.50 12.7 - 38.1	0° 22'	814300 3622187
	75 515	50 515	50 345	2	1.00 - 2.00 25.4 - 50.8	0° 22'	1221451 5433285
	100 690	75 690	50 345	2	1.00 - 2.00 25.4 - 50.8	0° 22'	1628601 7244379

- (1) For allowable test or transient pressure, the maximum working pressure may be increased to 1½ times the values shown.
- (2) Maximum allowable axial pipe movement at the joint is the difference between the maximum and minimum pipe end separation. At maximum pipe end separation, axial movement can only occur via pipe expansion into the joint and vice versa.
- (3) Pipe end movement and deflection are non-concurrent.
- (4) Published deflection values are intended and available for both static (installed) and dynamic (in-service) joint deflection. The coupling closure should be located 90 degrees from the direction of joint deflection.
- (5) The maximum permissible end loads listed in the table are calculated using the nominal pipe OD. The actual maximum permissible end load will be less or greater than the published figures depending on the actual pipe OD.

Style 233 Restrained Flexible Coupling For Dynamic Joint Deflection

RESTRAINT RINGS

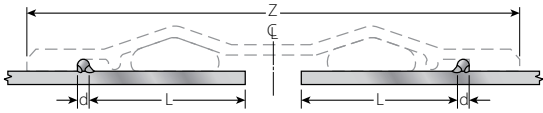

Type 2 - Restraint Ring Location

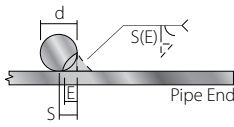

Restrained Ring Single Flare Bevel Groove Weld Detail

Back Weld - Must not extend past the back edge of the restraint ring

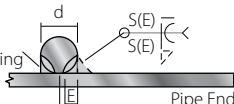

Restrained Ring Double Flare Bevel Groove Weld Detail

Nominal Pipe Size In./mm	(1) Maximum Working Pressure psi/kPa	(2) Body Type	Width (Z) In./mm	Restrained Ring		
				Diameter (d) In.	Location (L) In./mm	Weld Size (E) In.
8 200	300 2065	2	12.50 317.5	1/4	4.00 101.6	3/32
10 250	300 2065	2	12.50 317.5	1/4	4.00 101.6	3/32
12 300	200 1375	2	12.50 317.5	1/4	4.00 101.6	3/32
	300 2065	2	12.50 317.5	1/4	4.00 101.6	3/32
14 350	200 1375	2	12.50 317.5	1/4	4.00 101.6	3/32
	300 2065	2	12.50 317.5	1/4	4.00 101.6	3/32
16 400	200 1375	2	12.50 317.5	1/4	4.00 101.6	3/32
	300 2065	3	12.50 317.5	3/8	3.88 98.4	1/8
18 450	200 1375	2	12.50 317.5	1/4	4.00 101.6	3/32
	300 2065	2	12.50 317.5	3/8	3.88 98.4	1/8
20 500	200 1375	2	12.50 317.5	1/4	4.00 101.6	3/32
	300 2065	2	12.50 317.5	3/8	3.88 98.4	1/8
24 600	150 1035	2	12.50 317.5	1/4	4.00 101.6	3/32
	250 1725	2	12.50 317.5	3/8	3.88 98.4	1/8
	300 2065	2	12.50 317.5	3/8	3.88 98.4	1/8
30 750	100 690	2	12.50 317.5	1/4	4.00 101.6	3/32
	200 1375	2	12.50 317.5	3/8	3.88 98.4	1/8
	300 2065	2	12.50 317.5	3/8	3.88 98.4	1/8
36 900	150 1035	2	12.50 317.5	3/8	3.88 98.4	1/8
	250 1725	2	12.50 317.5	3/8	3.88 98.4	1/8
	300 2065	2	14.75 374.7	1/2	4.38 111.1	5/32
42 1050	150 1035	2	12.50 317.5	3/8	3.88 98.4	1/8
	200 1375	2	12.50 317.5	3/8	3.88 98.4	1/8
	300 2065	2	14.75 374.7	1/2	4.38 111.1	5/32

- (1) For allowable test or transient pressure, the maximum working pressure may be increased to 1½ times the values shown.
- (2) For applications other than air or gas, where a liquid or other medium is flowing through pipe, restraint ring weld requirements are as follows:
Type 2 couplings require a full circumferential double flare bevel groove weld based on the weld sizes shown in the table. For low pressure air or gas applications, where the weight of the medium flowing through the pipe is not a consideration, a single flare bevel groove weld and/or less than a full circumference of weld may be allowed to attach the restraint rings. Contact Victaulic for specific details. Each restraint ring shipment includes restraint ring placement and welding data that is specific to application or project requirements.
- (3) Restraint rings must be welded perpendicular to the pipe axis with a tolerance of $\pm 1/16$ in.
- (4) Flare bevel groove weld size in table is the minimum requirement. Depth of preparation $S = (d) \div 2$;
Weld size $E \approx S * 0.625$ per AWS D1.1. For a double flare bevel groove weld, the weld on the back side of the restraint ring must not extend beyond the outermost edge of the ring. The coupling shoulder must have unrestricted contact with the ring and the pipe O.D.

Note: The data in this table only applies when carbon steel couplings are being used on carbon steel pipe.

Style 233 Restrained Flexible Coupling For Dynamic Joint Deflection

RESTRAINT RINGS

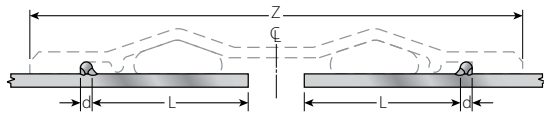

Type 2 - Restraint Ring Location

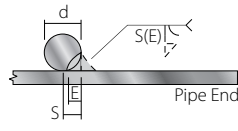

Restraint Ring Single Flare Bevel Groove Weld Detail

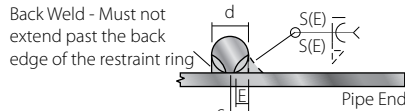

Restraint Ring Double Flare Bevel Groove Weld Detail

Nominal Pipe Size In./mm	(1) Maximum Working Pressure psi/kPa	(2) Body Type	Width (Z) In./mm	Restraint Ring		
				Diameter (d) In.	Location (L) In./mm	Weld Size (E) In.
48 1200	100 690	2	12.50 317.5	3/8	3.88 98.4	1/8
	150 1035	2	12.50 317.5	3/8	3.88 98.4	1/8
	250 1725	2	14.75 374.7	1/2	4.38 111.1	5/32
	300 2065	2	15.00 381.0	5/8	4.38 111.1	7/32
54 1350	150 1035	2	12.50 317.5	3/8	3.88 98.4	1/8
	200 1375	2	14.75 374.7	1/2	4.38 111.1	5/32
	250 1725	2	15.00 381.0	5/8	4.38 111.1	7/32
60 1500	150 1035	2	12.50 317.5	3/8	3.88 98.4	1/8
	200 1375	2	14.75 374.7	1/2	4.38 111.1	5/32
	250 1725	2	15.00 381.0	5/8	4.38 111.1	7/32
66 1650	100 690	2	12.50 317.5	3/8	3.88 98.4	1/8
	150 1035	2	14.75 374.7	1/2	4.38 111.1	5/32
	200 1375	2	15.00 381.0	5/8	4.38 111.1	7/32
72 1800	100 690	2	12.50 317.5	3/8	3.88 98.4	1/8
	150 1035	2	14.75 374.7	1/2	4.38 111.1	5/32
	200 1375	2	15.00 381.0	5/8	4.38 111.1	7/32
78 1950	100 690	2	12.50 317.5	3/8	3.88 98.4	1/8
	150 1035	2	14.75 374.7	1/2	4.38 111.1	5/32
	175 1200	2	15.00 381.0	5/8	4.38 111.1	7/32
84 2100	100 690	2	12.50 317.5	3/8	3.88 98.4	1/8
	150 1035	2	14.75 374.7	1/2	4.38 111.1	5/32
	175 1200	2	15.00 381.0	5/8	4.38 111.1	7/32
90 2250	100 690	2	12.50 317.5	3/8	3.88 98.4	1/8
	125 860	2	14.75 374.7	1/2	4.38 111.1	5/32
	150 1035	2	15.00 381.0	5/8	4.38 111.1	7/32

- (1) For allowable test or transient pressure, the maximum working pressure may be increased to 1½ times the values shown.
- (2) For applications other than air or gas, where a liquid or other medium is flowing through pipe, restraint ring weld requirements are as follows:
 Type 2 couplings require a full circumferential double flare bevel groove weld based on the weld sizes shown in the table. For low pressure air or gas applications, where the weight of the medium flowing through the pipe is not a consideration, a single flare bevel groove weld and/or less than a full circumference of weld may be allowed to attach the restraint rings. Contact Victaulic for specific details. Each restraint ring shipment includes restraint ring placement and welding data that is specific to application or project requirements.
- (3) Restraint rings must be welded perpendicular to the pipe axis with a tolerance of $L \pm \frac{1}{16} \times 1.6$ mm.
- (4) Flare bevel groove weld size in table is the minimum requirement. Depth of preparation $S = (d) \div 2$;
 Weld size $E \approx S * 0.625$ per AWS D1.1. For a double flare bevel groove weld, the weld on the back side of the restraint ring must not extend beyond the outermost edge of the ring. The coupling shoulder must have unrestricted contact with the ring and the pipe O.D.

Note: The data in this table only applies when carbon steel couplings are being used on carbon steel pipe.

Style 233 Restrained Flexible Coupling For Dynamic Joint Deflection

RESTRAINT RINGS

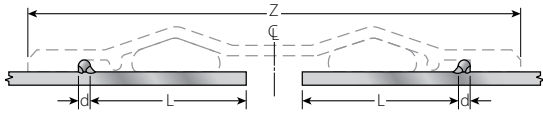

Type 2 - Restraint Ring Location

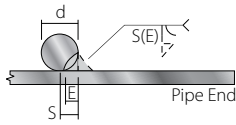

Restraint Ring Single Flare Bevel Groove Weld Detail

Back Weld - Must not extend past the back edge of the restraint ring

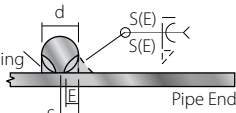

Restraint Ring Double Flare Bevel Groove Weld Detail

Nominal Pipe Size In./mm	(1) Maximum Working Pressure psi/kPa	(2) Body Type	Width (Z) In./mm	Restraint Ring		
				Diameter (d) In.	(3) Location (L) In./mm	(4) Weld Size (E) In.
96 2400	100 690	2	12.50 317.5	3/8	3.88 98.4	1/8
	125 860	2	14.75 374.7	1/2	4.38 111.1	5/32
	150 1035	2	15.00 381.0	5/8	4.38 111.1	7/32
108 2700	75 515	2	12.50 317.5	3/8	3.88 98.4	1/8
	100 690	2	14.75 374.7	1/2	4.38 111.1	5/32
	125 860	2	15.00 381.0	5/8	4.38 111.1	7/32
120 3000	75 515	2	12.50 317.5	3/8	3.88 98.4	1/8
	100 690	2	14.75 374.7	1/2	4.38 111.1	5/32
	125 860	2	15.00 381.0	5/8	4.38 111.1	7/32
144 3600	50 345	2	12.50 317.5	3/8	3.88 98.4	1/8
	75 515	2	14.75 374.7	1/2	4.38 111.1	5/32
	100 690	2	15.00 381.0	5/8	4.38 111.1	7/32

- (1) For allowable test or transient pressure, the maximum working pressure may be increased to 1½ times the values shown.
- (2) For applications other than air or gas, where a liquid or other medium is flowing through pipe, restraint ring weld requirements are as follows:
Type 2 couplings require a full circumferential double flare bevel groove weld based on the weld sizes shown in the table. For low pressure air or gas applications, where the weight of the medium flowing through the pipe is not a consideration, a single flare bevel groove weld and/or less than a full circumference of weld may be allowed to attach the restraint rings. Contact Victaulic for specific details. Each restraint ring shipment includes restraint ring placement and welding data that is specific to application or project requirements.
- (3) Restraint rings must be welded perpendicular to the pipe axis with a tolerance of $\pm 1/16 \pm 1.6$ mm.
- (4) Flare bevel groove weld size in table is the minimum requirement. Depth of preparation $S = (d) \div 2$;
Weld size $E \approx S * 0.625$ per AWS D1.1. For a double flare bevel groove weld, the weld on the back side of the restraint ring must not extend beyond the outermost edge of the ring. The coupling shoulder must have unrestricted contact with the ring and the pipe O.D.

Note: The data in this table only applies when carbon steel couplings are being used on carbon steel pipe.

Style 233 Restrained Flexible Coupling For Dynamic Joint Deflection

CLOSURE TOOLS



MANUAL TOOL



HYDRAULIC TOOL

Manual Tools

- CTM-01: for use on 5" and 8" body widths
- CTM-02: for use on 10" body widths
for use on 12" body widths with thickness of $\frac{3}{16}$ " or less

Hydraulic Tools

- CTH-01*: for use on 12" body widths with thickness of $\frac{1}{4}$ " or greater
for use on 14", 16" and 18" body widths
- CTH-02: for use on all type 3 couplings

- Hydraulic tool package comes standard with:

- one (1) tool head
- one (1) hydraulic cylinder
- one (1) hydraulic hose
- one (1) hand pump

* A CTH-01 hydraulic closure tool can be used in applications where the CTM-02 manual closure tool is recommended.

Note: The closure tools listed above are designed specifically for Victaulic Style 230, 231, 232 and 233 couplings. If ordering custom product, contact Victaulic for appropriate tool selection.

Style 233 Restrained Flexible Coupling For Dynamic Joint Deflection

PRODUCT CONFIGURATOR

C 0233 0144 50 S 2 D E P S SO

Class	Style	Actual Pipe O.D.*		Body Type	Segments	PSI/kPa Rating	Rubber Compound	Paint	Hardware	Ring and Pipe Material
		Inches [^]	Fraction							
C	0233	0007 through 0150	00 - 0 13 - 1/8 25 - 1/4 38 - 3/8 50 - 1/2 63 - 5/8 75 - 3/4 88 - 7/8	S - Carbon	1 - One 2 - Two	A - 25/170 B - 50/345 C - 75/515 D - 100/690 E - 125/860 F - 150/1035 G - 175/1200 H - 200/1375 J - 250/1725 K - 300/2056	E - EPDM I - Isoprene L - Silicone T - Nitrile V - Neoprene O - Fluoro-elastomer	F - Fusion bonded epoxy P - Orange enamel T - Shop primer B - Liquid epoxy N - Fusion bonded nylon G - Galvanized 0 - None	S - Carbon X - Stainless	SO - Carbon Steel Ring on Carbon Steel Pipe DO - Carbon Steel Ring on Ductile Iron Pipe XO - Stainless Steel Ring on Stainless Steel Pipe

[^] Couplings are available in a range of nominal sizes from 8 - 144".
* For actual pipe O.D. round down to the nearest 1/8" to determine proper coupling size required.

ENGINEERED PRODUCTS OPTIONS

For non-standard products the Victaulic Engineered Products group can assist with specialty joints designed to meet the specific size, pressure and temperature requirements of your system.

WARRANTY

Refer to the Warranty section of the current Price List or contact Victaulic for details.

NOTE

This product shall be manufactured by Victaulic or to Victaulic specifications. All products to be installed in accordance with current Victaulic installation/assembly instructions. Victaulic reserves the right to change product specifications, designs and standard equipment without notice and without incurring obligations.

TESTING

Victaulic Style 233 couplings are designed to allow for a 50 percent increase over the published maximum working pressure for test and/or transient pressures. Due to the huge volume of air that can be involved in jobsite air testing and the nature of air or gas that is pressurized, jobsite air testing should be limited to 25 psi/175 kPa or less.

Victaulic offers a dished head assembly prepared with a restraint ring for the Style 233 coupling for field testing a section of pipeline or to end a pipeline and allow for future expansion. Contact Victaulic for details.

For complete contact information, visit www.victaulic.com

60.07 5826 REV L UPDATED 06/2022

VICTAULIC IS A REGISTERED TRADEMARK OF VICTAULIC COMPANY. © 2022 VICTAULIC COMPANY. ALL RIGHTS RESERVED.

