

Style 240S Bellows Expansion Joint For Stainless Steel Pipe

The Victaulic Bolted Split-Sleeve Products (VBSP) style 240S stainless steel bellows expansion joint (formerly Depend-O-Lok OmniFlex) is designed to provide for thermal expansion and contraction, vibration reduction and lateral offset at pipeline joints. Bellows type expansion joints can accommodate three different types of movements; axial, lateral and angular. These movements can be concurrent. However, values for non concurrent movement cannot exceed values for a single concurrent movement. This can be achieved and needs to be specified at time of order. Each joint is built from 304, 316 or 321 stainless steel to accommodate specific application needs.



3 - 96/80 - 2400MM

In applications where flow induced vibrations, turbulent flow or erosion due to the material carried in the line is a concern, the Style 240S bellows expansion joint can be manufactured with an internal liner. Liners can drastically reduce noise and are also recommended for high velocity flows or pipelines operating at high temperatures.

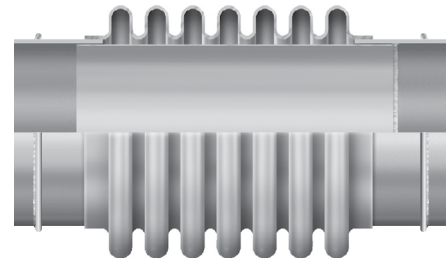

WITH INTERNAL LINER

JOB/OWNER

System No. _____

Location _____

CONTRACTOR

Submitted By _____

Date _____

ENGINEER

Spec Sect _____ Para _____

Approved _____

Date _____

Style 240S Bellows Expansion Joint For Stainless Steel Pipe

CONFIGURATIONS

The Victaulic Style 240S bellows expansion joint is available in a variety of end configurations to meet system needs. Common end configurations include the following:

- Plain end
- Beveled end
- AGS grooved
- With restraint ring (for use with style 234S couplings)
- Floating flanged
- Fixed flanged



This style of joint requires proper joint support to protect the bellows element from hypercompression and hyperextension. Limit rods may be provided with the joint for this purpose. Harness rods and lugs may also be used in conjunction with style 240S bellows expansion joint to accommodate full bulkhead thrust generated by internal pressure. In addition, optional bellow covers are available to protect the joint during installation and normal operation. Pipe support requirements are defined within the Application Data document. Please see publication 26.20.

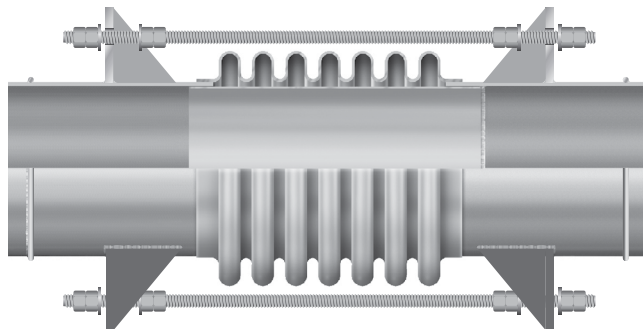

Please contact the Victaulic Engineered Products group ProjectCoordination@victaulic.com to assist with specialty joints designed to meet the specific size, pressure, temperature and movement requirements of your system.

Style 240S Bellows Expansion Joint Quote Check Sheet

Send US, Asia, and Europe inquiries to: ProjectCoordination@victaulic.com or fax to: 610-923-3010
 To speak with a Customer Service representative in the US, please call 1-800-PICK-VIC
 In Canada, please e-mail vcoc_spr@victaulic.com or fax (905) 884-9774

The following information is required to ensure a proper quote. For application information, please see www.victaulic.com or call Victaulic® at (800) 841-6624.

TO OBTAIN A QUOTE, PLEASE PROVIDE THE INFORMATION REQUESTED BELOW.

CUSTOMER CONTACT INFORMATION:

NAME:	DATE:
COMPANY:	PHONE:
ADDRESS:	FAX:
CITY:	E-MAIL:
STATE:	REQUESTED SHIPPING DATE:
ZIP:	
QUOTE NEEDED BY (DATE):	

PROJECT INFORMATION:

PROJECT NAME:	BID DATE:
CITY & STATE:	
ENGINEERING FIRM:	CONTACT NAME:
CITY & STATE:	PHONE:
<input type="checkbox"/> PROJECT SPECIFICATION INCLUDED	

PIPE INFORMATION:

PIPE SIZE	NOMINAL PIPE SIZE:	ACTUAL PIPE OD:
PIPE MATERIAL	<input type="checkbox"/> Carbon Steel	<input type="checkbox"/> Stainless Steel
	<input type="checkbox"/> Other:	<input type="checkbox"/> Ductile Iron

Style 240S Bellows Expansion Joint Quote Check Sheet

SERVICE INFORMATION:

OPERATING TEMPERATURE RANGE	MIN. °F/°C:	MAX. °F/°C:
PRESSURE	WORKING PSI:	TEST / TRANSIENT PSI:
SERVICE	<input type="checkbox"/> AIR <input type="checkbox"/> WATER	<input type="checkbox"/> OTHER / SPECIFY:
AXIAL MOVEMENT:		
COMPRESSION	IN/MM	
EXTENSION	IN/MM	
TOTAL AXIAL MOVEMENT	IN/MM	AXIAL SPRING RATE:
LATERAL MOVEMENT	IN/MM	LATERAL SPRING RATE:
ANGULAR MOVEMENT	°	ANGULAR SPRING RATE:
DESIGN FOR VIBRATION	<input type="checkbox"/>	
CYCLE LIFE (2,000 CYCLES MIN.)		

MATERIALS:

BELLOWS CAPSULES – STAINLESS	<input type="checkbox"/> 321 SERIES	<input type="checkbox"/> 316 SERIES	<input type="checkbox"/> 304 SERIES
------------------------------	-------------------------------------	-------------------------------------	-------------------------------------

END CONNECTIONS:

	PIPE A	PIPE B (same as Pipe A if blank)
PLAIN END	<input type="checkbox"/> Specify Mat'l	<input type="checkbox"/> Specify Mat'l
BEVELED FOR WELDING	<input type="checkbox"/> Specify Mat'l	<input type="checkbox"/> Specify Mat'l
RESTRAINED COUPLING	<input type="checkbox"/> Specify Coupling	<input type="checkbox"/> Specify Coupling
AGS GROOVED COUPLING	<input type="checkbox"/> Specify Coupling	<input type="checkbox"/> Specify Coupling
FLANGE – FIXED (WELDED)	<input type="checkbox"/>	<input type="checkbox"/>
FLANGE – FLOATING (VAN STONE)	<input type="checkbox"/>	<input type="checkbox"/>
NOMINAL SIZE		
FLANGE STANDARD / TYPE		
FLANGE MATERIAL		
OTHER REQUIREMENTS		

ADDITIONAL OPTIONS:

<input type="checkbox"/> INTERNAL LINER (non-sealed)	<input type="checkbox"/> SHROUD (Mat'l?)	<input type="checkbox"/> LIFTING LUGS
<input type="checkbox"/> STAINLESS STEEL LIMIT RODS	<input type="checkbox"/> CARBON STEEL LIMIT RODS	
<input type="checkbox"/> SPECIAL (Define Requirements)		

Note: Please fill out the above information as completely as possible to ensure receiving the most accurate quote that we can provide.

Style 240S Bellows Expansion Joint For Stainless Steel Pipe

TESTING

Victaulic recommends due to the huge volume of air that can be involved in jobsite air testing and the nature of air or gas that is pressurized, that jobsite air testing should be limited to 25 psi/175 kPa or less.

WARRANTY

Refer to the Warranty section of the current Price List or contact Victaulic for details.

NOTE

This product shall be manufactured by Victaulic or to Victaulic specifications. All products to be installed in accordance with current Victaulic installation/assembly instructions. Victaulic reserves the right to change product specifications, designs and standard equipment without notice and without incurring obligations.

For complete contact information, visit www.victaulic.com

60.13 7129 REV C UPDATED 12/2022

VICTAULIC IS A REGISTERED TRADEMARK OF VICTAULIC COMPANY. © 2022 VICTAULIC COMPANY. ALL RIGHTS RESERVED.

60.13

