

# Victaulic® FireLock™ No. 102 (Straight Tee) Installation-Ready™ Fitting



**WARNING**

- Read and understand all instructions before attempting to install any Victaulic piping products.
- Depressurize and drain the piping system before attempting to install, remove, adjust, or maintain any Victaulic piping products.
- Wear safety glasses, hardhat, and foot protection.

Failure to follow these instructions could result in death or serious personal injury and property damage.

## IMPORTANT INFORMATION FOR THE 1-INCH/33.7-MM NO. 102

IGS Groove Profile for 1-inch/DN25 No. 102 Only



OGS Groove Profile for All Other No. 102 Sizes



The 1-inch/DN25 No. 102 Installation-Ready™ Fitting shall be used **ONLY** with mating components that are prepared to Victaulic IGS proprietary groove specifications. **DO NOT** attempt to install 1-inch/DN25 No. 102 Installation-Ready™ Fittings on mating components that are prepared to any other groove specification. Refer to Victaulic publication 25.14 for the 1-inch/DN25 IGS groove specification, which can be downloaded at victaulic.com.

## INSTALLATION METHOD 1

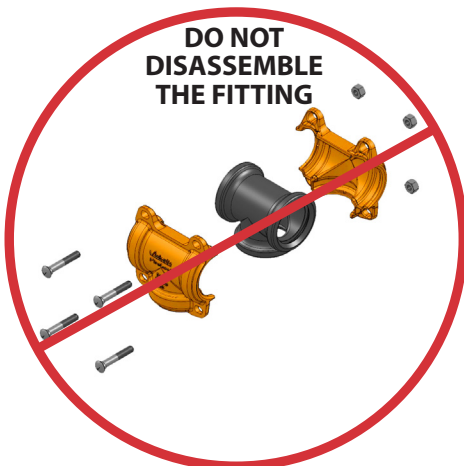

**1. DO NOT DISASSEMBLE THE FITTING:** Victaulic® FireLock™ No. 102 Installation-Ready™ Fittings are designed so that the installer does not need to remove the bolts and nuts for installation. This design facilitates installation by allowing the installer to directly insert the grooved end of mating components into the fitting.

**2. CHECK MATING COMPONENT ENDS:** The outside surface of the mating component, between the groove and the mating component end, shall be smooth and free from indentations, projections, weld seams, and roll marks to ensure a leak-tight seal. All oil, grease, loose paint, dirt, and cutting particles shall be removed.

The mating components' outside diameter ("OD"), groove dimensions, and maximum allowable flare diameter shall be within the tolerances published in current Victaulic grooving specifications (publication 25.14 for 1-inch/DN25 IGS and publication 25.01 for 1 ¼-inch/DN32 and larger OGS), which can be downloaded at victaulic.com.

**3. CHECK GASKET:** Check the gasket to verify that it is suitable for the intended service. The color code identifies the material grade. Refer to Victaulic publication 05.01 for the color code chart, which can be downloaded at victaulic.com. **REFER TO THE NOTICE BELOW FOR IMPORTANT GASKET INFORMATION.**

## NOTICE

- Victaulic No. 102 Fittings are designed for use **ONLY** in fire protection systems.
- Gaskets for Victaulic No. 102 Fittings are provided with *Vic-Plus*. Additional lubrication is not required for the initial installation of wet pipe systems that are installed at or continuously operating above 0°F/-18°C. Refer to Victaulic publication 05.03 for the *Vic-Plus* Material Safety Data Sheet (MSDS), which can be downloaded at victaulic.com.

Supplemental lubrication is required for *Vic-Plus* gaskets only if any of the following conditions exist. If any of these conditions exist, apply a thin coat of Victaulic lubricant or silicone lubricant to the sealing lips of the gasket interior only.

- If the gasket has been exposed to fluids prior to installation
- If the surface of the gasket does not have a hazy appearance
- If the gasket is being installed into a dry pipe system
- If the system will be subjected to air tests prior to being filled with water
- If the gasket was involved in a previous installation
- If the gasket sealing surfaces of the mating components contain raised or undercut weld seams, or cracks or voids at the weld seams

However, lubricated gaskets may not enhance sealing capabilities on adverse mating component conditions. Mating component condition and preparation shall conform to the requirements listed in these product installation instructions.

**WARNING**

- Never leave a No. 102 Fitting partially installed on mating component ends. A partially-installed fitting poses a drop or burst hazard during testing.
- Keep hands away from the mating component ends and the openings of the fitting when attempting to insert grooved mating component ends into the fitting.
- Keep hands away from fitting openings during tightening.

Failure to follow these instructions could result in death or serious personal injury and property damage.



**4. INSERT MATING COMPONENTS INTO THE RUN ENDS:** Assemble the joint by inserting a grooved mating component end into each of the run ends of the fitting. The grooved mating component ends shall be inserted into the fitting until contact with the pipe stop of each gasket occurs.

A visual check is required to verify that the fitting's keys align with the groove in each mating component end.

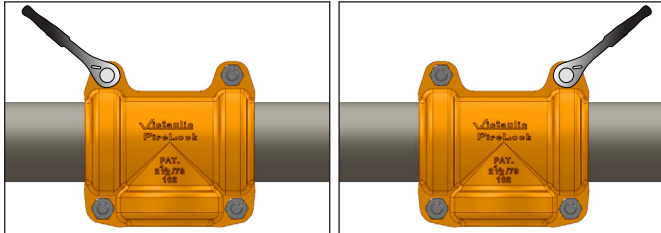

**4a. TIGHTEN NUTS ALONG THE RUN SIDE:** Tighten nuts along run side evenly by alternating sides until metal-to-metal contact occurs at the bolt pads. Verify that the fitting's keys engage the groove completely and that the oval neck of the bolts seat properly in the bolt holes.

**⚠ WARNING**

- At this point, the fitting is only partially installed.
- The fitting shall be treated as a potential drop hazard and shall not be left unattended.

Failure to follow these instructions could result in death or serious personal injury and property damage.

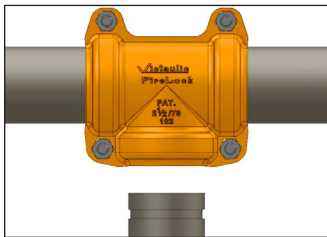

**5. INSERT MATING COMPONENT INTO THE BRANCH END:** Insert the third grooved mating component end into the opening of the branch end. The grooved mating component end shall be inserted into the fitting until contact with the pipe stop of the gasket occurs.

A visual check is required to verify that the fitting's keys align with the groove in the mating component end. **NOTE:** If the mating component cannot be inserted into the fitting, incrementally loosen the nuts that were tightened in step 4a just until the mating component is inserted (refer to warning above).

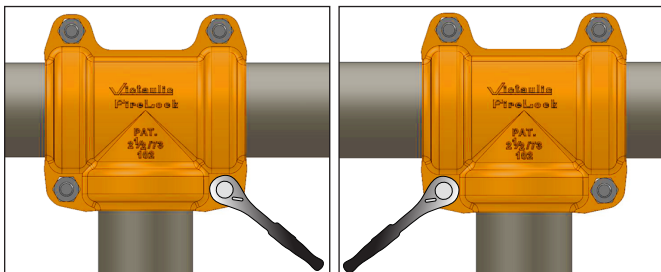

**5a. COMPLETELY TIGHTEN NUTS ALONG THE BRANCH SIDE:** Completely tighten nuts along branch side evenly by alternating sides until metal-to-metal contact occurs at the bolt pads. Verify that the fitting's keys engage the groove completely and that the oval neck of the bolts seat properly in the bolt holes.

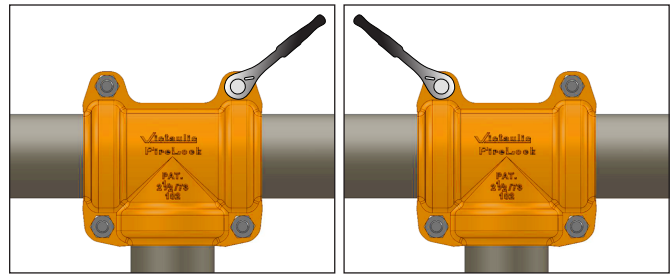

**6. COMPLETELY TIGHTEN NUTS ALONG THE RUN SIDE:** Completely tighten nuts along run side, ensuring metal-to-metal contact at the bolt pads. Verify that the fitting's keys engage the groove completely and that the oval neck of the bolts seat properly in the bolt holes.

**⚠ WARNING**

- Nuts shall be tightened completely until metal-to-metal contact with positive or neutral offsets occurs at the angled bolt pads and metal-to-metal contact occurs at the flat bolt pads, as described in Step 7 on the following page.

Failure to tighten all nuts completely may cause joint failure, resulting in death or serious personal injury and property damage.

**NOTICE**

- It is important to tighten all nuts until metal-to-metal contact occurs at all bolt pads, as instructed in the tightening sequence on this page.
- An impact wrench or standard socket wrench with a deep-well socket can be used to bring the bolt pads into metal-to-metal contact.
- Refer to the "Helpful Information" and "Impact Wrench Usage Guidelines" sections.

**HELPFUL INFORMATION**

Nominal Size inches/DN	Actual Outside Diameter inches/mm	Nut Size inches/Metric	Deep-Well Socket Size inches/mm
1 DN25	1.315 33.7	3/8 M10	1 1/16 17
1 1/4 DN32	1.660 42.1	3/8 M10	1 1/16 17
1 1/2 DN40	1.900 48.3	3/8 M10	1 1/16 17
2 DN50	2.375 60.3	7/16 M11	3/4 19
2 1/2	2.875 73.0	7/16 M11	3/4 19
DN65	3.000 76.1	7/16 M11	3/4 19

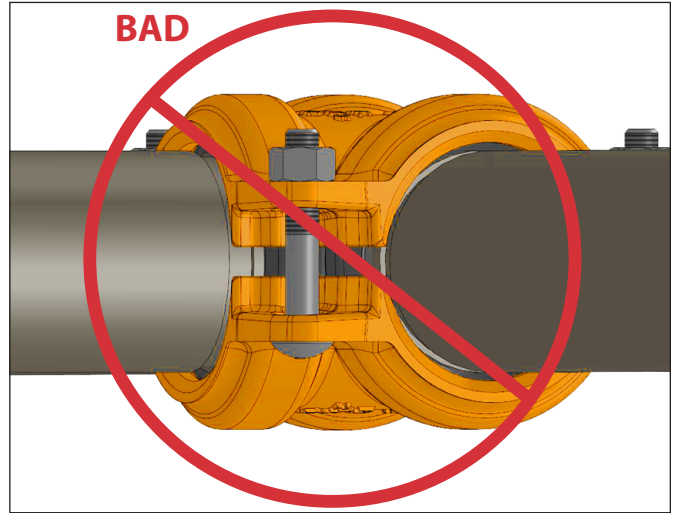
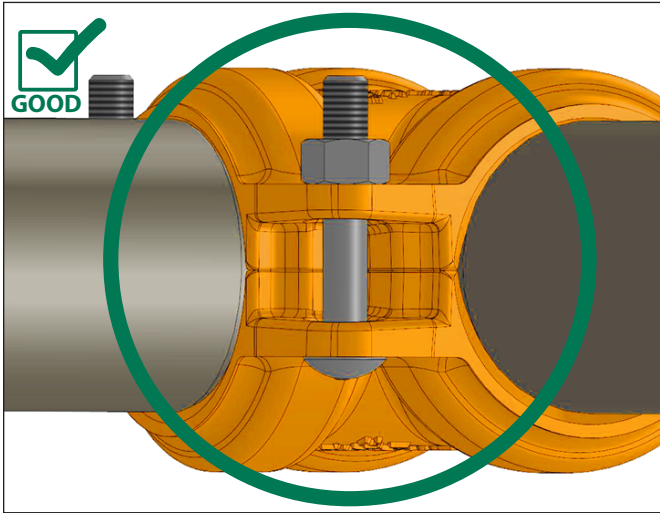

**7. VERIFY THAT ALL NUTS ARE TIGHTENED COMPLETELY AND THAT METAL-TO-METAL CONTACT IS ACHIEVED AT ALL BOLT PADS:** Visually inspect all bolt pads at each joint to confirm metal-to-metal contact with positive or neutral offsets at the angled bolt pads and metal-to-metal contact at the flat bolt pads. If the bolt pads do not reach metal-to-metal contact, loosen the nuts at the angled bolt pads, then retighten all nuts evenly by alternating sides. If the bolt pads still do not reach metal-to-metal contact, remove the fitting from the mating component ends and verify that the mating components' outside diameter ("OD"), groove dimensions, and maximum allowable flare diameter are within the tolerances published in current Victaulic grooving specifications (publication 25.14 for 1-inch/DN25 IGS and publication 25.01 for 1 ¼-inch/DN32 and larger OGS).

**NOTE:** Before pressurizing the system, the fitting may be adjusted by loosening the appropriate hardware. After repositioning the fitting, the hardware shall be retightened until the installation requirements listed in these instructions are achieved.

## INSTALLATION METHOD 2

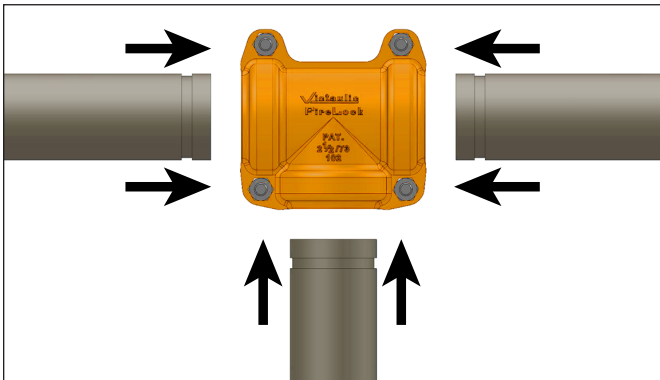

**1.** When practical, all grooved mating component ends may be inserted into the fitting prior to tightening. In this case, the hardware shall be tightened evenly by alternating sides until the installation requirements listed in these instructions are achieved.

**2.** Before pressurizing the system, the fitting may be adjusted by loosening the appropriate hardware. After repositioning the fitting, the hardware shall be retightened until the installation requirements listed in these instructions are achieved.

## IMPACT WRENCH USAGE GUIDELINES

### **⚠ WARNING**

- Nuts shall be tightened completely until metal-to-metal contact with positive or neutral offsets occurs at the angled bolt pads and metal-to-metal contact occurs at the flat bolt pads.
  - **DO NOT** continue to tighten the nuts after the visual installation guidelines for the fitting, described in Step 7 above, are achieved.
- Failure to follow these instructions could cause gasket pinching and fitting damage, resulting in death or serious personal injury and property damage.

Impact wrenches do not provide the installer with direct "wrench feel" or torque to judge nut tightness. Since some impact wrenches are capable of high output, it is important to develop a familiarity with the impact wrench to avoid damaging or fracturing the bolts or the fitting's bolt pads during installation. **DO NOT continue to tighten the nuts after the visual installation guidelines for the fitting, described in Step 7 above, are achieved.**

If the battery is drained or if the impact wrench is under-powered, a new impact wrench or a new battery pack shall be used to ensure that the visual installation guidelines for the fitting, described in Step 7 above, are achieved.

Perform trial assemblies with the impact wrench and check the assemblies with socket or torque wrenches to help determine the capability of the impact wrench. Using the same method, periodically check additional nuts throughout the system installation.

For safe and proper use of impact wrenches, always refer to the impact wrench manufacturer's operating instructions. In addition, verify that proper impact grade sockets are being used for fitting installation.



### **⚠ WARNING**

- Failure to follow instructions for tightening fitting hardware could result in:
- Personal injury or death
  - Bolt fractures
  - Damaged or broken bolt pads or fitting fractures
  - Joint leakage

# Victaulic® FireLock™ No. 102 (Straight Tee) Installation-Ready™ Fitting

## REMOVAL OF A FITTING FROM THE SYSTEM

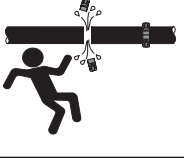
**⚠ WARNING**

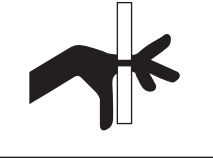
- Verify that the system is depressurized and drained completely before attempting to remove any fittings.
- Never leave a No. 102 Fitting partially installed on mating component ends. A partially-installed fitting poses a drop hazard.

Failure to follow these instructions could result in death or serious personal injury and property damage.

**NOTICE**

- No. 102 Fittings DO NOT need to be fully disassembled for removal.

1. Verify that the system is depressurized and drained completely before attempting to remove any fittings for maintenance.

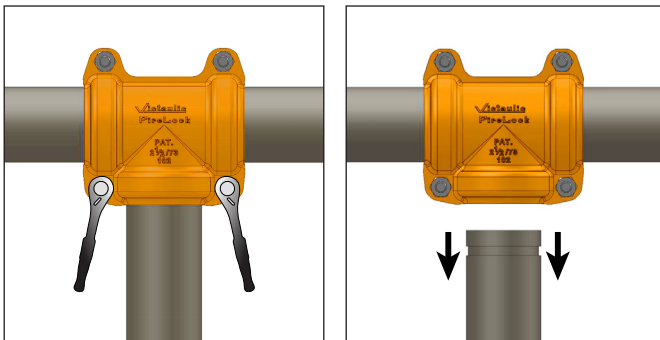

2. Loosen the nuts only along the branch side of the fitting. Remove the mating component from the loosened branch side. Verify that the fitting is secured to the other mating component ends on the run sides to prevent the fitting from falling.

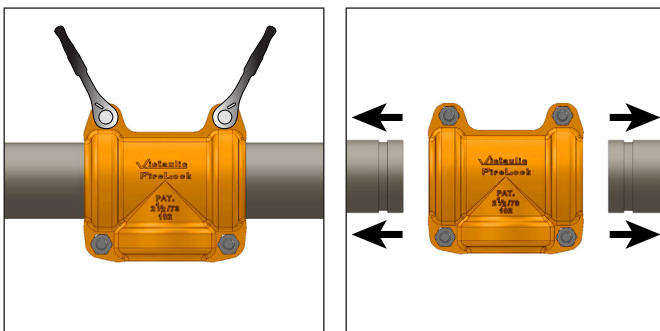

3. While supporting the fitting, loosen the nuts along the run side of the fitting. Carefully remove the fitting from the mating component.

4. Follow all steps of the "Installation Method 1" section on pages 1 – 3 to reinstall the joint.

## REASSEMBLY OF A FITTING THAT WAS FULLY DISASSEMBLED DURING REMOVAL FROM THE SYSTEM

**NOTICE**

- No. 102 Fittings DO NOT need to be fully disassembled for removal. However, if a fitting is fully disassembled during maintenance or for any other reason, the following steps shall be completed.
- The fitting shall be reassembled, as shown in the steps below, before attempting to reinstall the product.

1. Inspect the gasket for any damage or wear. If any damage or wear is present, replace the gasket with a new, Victaulic-supplied one of the same grade.

**⚠ CAUTION**

- A thin coat of Victaulic Lubricant or silicone lubricant shall be used to prevent the gasket from pinching/tearing during reassembly.

Failure to use a compatible lubricant will cause gasket damage, resulting in joint leakage and property damage.

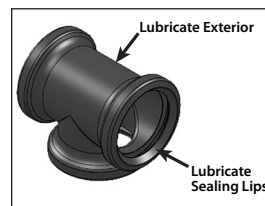

2. **FOR REASSEMBLY OF A FITTING, LUBRICATE GASKET:** Apply a thin coat of Victaulic Lubricant or silicone lubricant to the gasket's sealing lips and exterior. It is normal for the gasket to have a hazy white appearance after it has been in service.

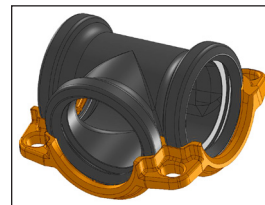

3. **INSTALL GASKET INTO FITTING HOUSING:** Install the gasket into one of the fitting's housings. Verify that the ends of the gasket are seated in the housing's pockets.

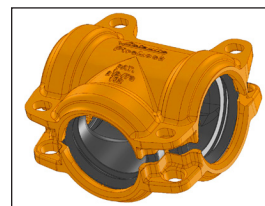

4. **INSTALL SECOND FITTING HOUSING:** Install the second fitting housing. Verify that the ends of the gasket are seated in the housings' pockets.

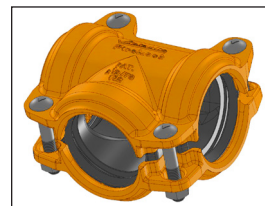

5. **INSTALL BOLTS AND NUTS:** Install the bolts, and thread a nut onto each bolt. **NOTE:** Verify that the oval neck of each bolt seats properly in the bolt hole. DO NOT tighten the nuts completely. The bolt pads need to be set at a gap for reinstallation of the fitting. Two to three full bolt threads, exposed above each nut, will provide the proper gap.

6. Follow all steps of the "Installation Method 1" section on pages 1 – 3 to reinstall the joint.

For complete contact information, visit [victaulic.com](http://victaulic.com)

I-102 9022 REV C UPDATED 04/2017 Z000102000

VICTAULIC, FIRELOCK, AND INSTALLATION-READY ARE REGISTERED TRADEMARKS OR TRADEMARKS OF VICTAULIC COMPANY AND/OR ITS AFFILIATED ENTITIES IN THE UNITED STATES AND/OR OTHER COUNTRIES. © 2017 VICTAULIC COMPANY. ALL RIGHTS RESERVED.

