

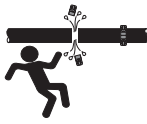



Victaulic® Style 231 Non-Restrained, Flexible Expansion Coupling with Cladding on Expansion Side of Pipe

ONE SEGMENT, TYPE 2

⚠ WARNING					
					
<ul style="list-style-type: none"> • Read and understand all instructions before attempting to install any Victaulic piping products. • Depressurize and drain the piping system before attempting to install, remove, or adjust any Victaulic piping products. • Wear safety glasses, hardhat, and foot protection when working with Victaulic piping products. • Keep hands away from pinch points at all times. <p>Failure to follow these instructions could result in serious personal injury, property damage, and/or product damage.</p>					

IMPORTANT INFORMATION

- **THESE INSTRUCTIONS MUST BE PROVIDED TO THE INSTALLER.** For the installation to be completed properly, **ALL** information contained in these instructions and the “Restraint Ring Placement and Welding Data” sheet **MUST** be considered before installation occurs. The “Restraint Ring Placement and Welding Data” sheet, supplied with every restraint ring and cladding shipment, contains important information regarding restraint ring placement and welding the cladding to the expansion end of the carbon steel pipe.
- Check the packing list to make sure all materials are available for installation. Contact your Victaulic sales representative immediately if parts are not available at the jobsite.
- Keep all products stored in their protective wrappings until they are ready for installation. O-rings should not be stored in direct sunlight or sub-freezing temperatures. **DO NOT** store anything on top of o-rings and sealing plates. Handle couplings with care to prevent damage to the sealing surfaces.
- The installer must have appropriate wrenches and socket devices to tighten the hardware that is supplied with the product. Wrenches and socket devices are not supplied with the product.
- **Couplings that contain stainless steel hardware may be shipped with two sets of studs.** The carbon steel hardware is used for installation purposes only, since stainless steel hardware is sensitive to seizing. Refer to the “Replacing Carbon Steel Installation Hardware” section for complete instructions.

ITEMS PROVIDED WITH SHIPMENT:

- Coupling
- Sealing Plate
- Rubber O-Rings of Different Diameters
- Pipe Joint Lubricant
- Studs with Flat Washers and Nuts

TOOLS REQUIRED FOR INSTALLATION:

- Hydraulic Closure Tool
- Long-Handled Ratchet Wrench
- Box Wrench



NOTE: Refer to the “Minimum Closure Tool Selection” table on the following page.

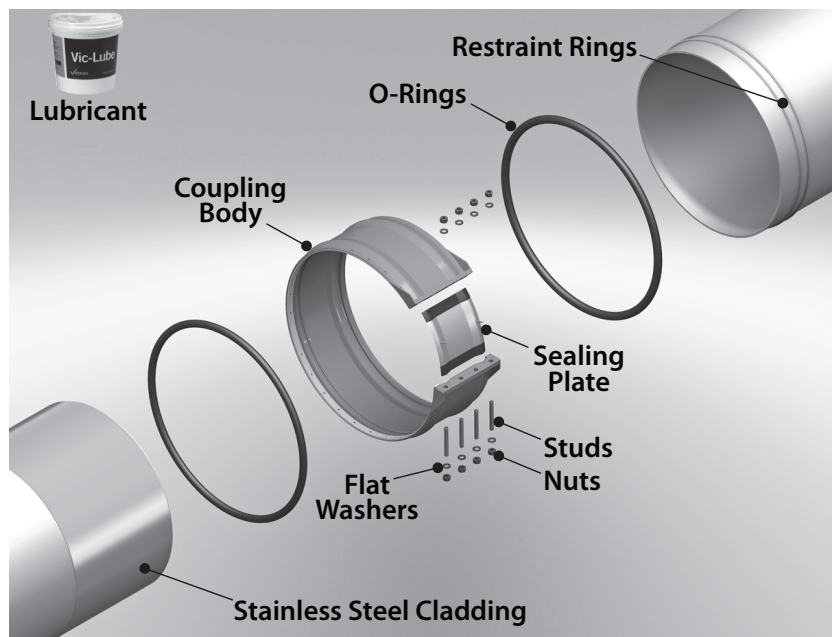

Victaulic® Style 231 Non-Restrained, Flexible Expansion Coupling with Cladding on Expansion Side of Pipe

ONE SEGMENT, TYPE 2

PIPE END PREPARATION

The “pipe end” is considered a distance equal to or greater than the total width of the coupling body. The exterior surface of the pipe **MUST** be smooth and free from weld reinforcement, weld bead, seams, scars, indentations, roll marks, and flat spots. Before installation, the pipe ends must be clean and free from oil, dirt, debris, sharp edges, and any foreign material that may interfere with joint sealing. Painted pipe ends must be free from knits and surface defects.

PIPE ROUNDNESS

Nominal Pipe Size	Tolerance on Roundness
Up to 14 inches Up to DN 350	Within ⅛ inch Within 3.2 mm
16 – 20 inches DN 400 – DN 500	Within 1 Percent
24 – 36 inches DN 600 – DN 900	Within ¾ Percent
42 – 108 inches DN 1050 – DN 2700	Within ½ Percent
Greater than 108 inches Greater than DN 2700	Within ⅓ Percent

PIPE DIAMETER TOLERANCE IF BOTH PIPES ARE THE SAME OD (PLUS/MINUS TOLERANCE STILL APPLIES)

Nominal Pipe Size	Tolerance on Actual OD (OD Based on Actual Pipe Circumference)
Up to 14 inches Up to DN 350	-0.06/+0.12 inch -1.5/+3.0 mm
16 – 36 inches DN 400 – DN 900	-0.08/+0.18 inch -2.0/+4.6 mm
42 – 54 inches DN 1050 – DN 1350	-0.12/+0.25 inch -3.0/+6.4 mm
60 – 144 inches DN 1500 – DN 3600	-0.25/+0.31 inch -6.4/+7.9 mm

ALLOWABLE PIPE MISALIGNMENT

Nominal Pipe Size	Allowable Misalignment
Up to 20 inches Up to DN 500	⅜ inch 4.8 mm
24 – 54 inches DN 600 – DN 1350	¼ inch 6.4 mm
Greater than 60 inches Greater than DN 1500	⅜ inch 9.5 mm

PLUS/MINUS TOLERANCE ALLOWABLE DIFFERENCE BETWEEN PIPE DIAMETERS AT JOINT

Nominal Pipe Size	Allowable Pipe OD Difference (OD Based on Actual Pipe Circumference)
Up to 16 inches Up to DN 400	0.12 inch 3.0 mm
18 – 24 inches DN 450 – DN 600	0.16 inch 4.1 mm
30-inch and Larger DN 760 and Larger	0.20 inch 5.1 mm

MINIMUM CLOSURE TOOL SELECTION

Description	Applications
CTH-01 Hydraulic Closure Tool *	12-inch/300-mm Coupling Body Widths with a Thickness of ¼ inch and Greater
	14-inch/350-mm, 16-inch/400-mm, and 18-inch/450-mm Coupling Body Widths
CTH-02 Hydraulic Closure Tool *	All Type 3 Couplings

* The hydraulic tool package comes standard with one tool head, one hydraulic cylinder, one hydraulic hose, and one hand pump.

NOTE: The closure tools listed in this table are designed specifically for Victaulic Style 230, 231, 232, and 233 Couplings.

Victaulic® Style 231 Non-Restrained, Flexible Expansion Coupling with Cladding on Expansion Side of Pipe

ONE SEGMENT, TYPE 2

INSTALLATION

⚠ CAUTION

- O-rings, pipe ends, both sides of the sealing plate, and interior coupling body surfaces **MUST** be lubricated for proper product installation.
 - Protect lubricated surfaces from dirt and debris.
- Failure to properly lubricate the product could cause rolling or pinching of the o-rings, resulting in joint leakage and property damage.

1. Refer to the “Restraint Ring Placement and Welding Data” sheet to inspect restraint ring placement on the fixed side and cladding on the expansion side. Make sure the restraint ring is located on the fixed side pipe end per the specification and that the attachment welds comply with weld requirements.

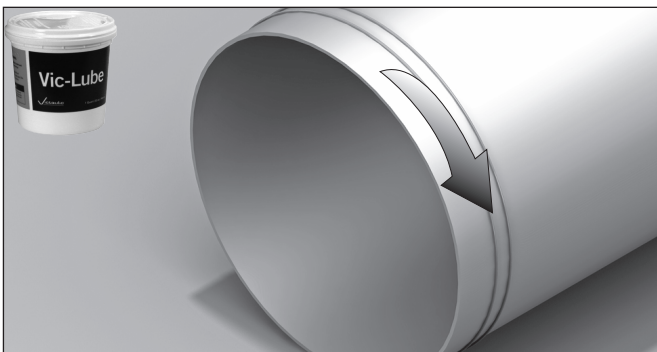
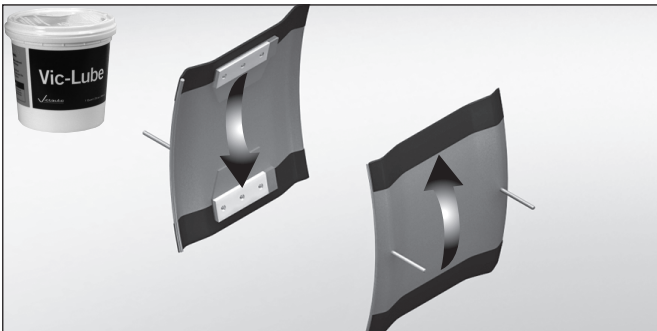
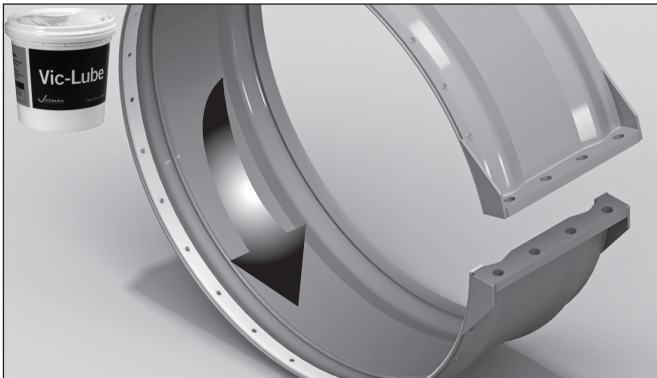

2. Make sure the interior surface of the coupling body is clean. Apply an even coat of lubricant (provided with the product) to the interior surface of the coupling body, both sides of the sealing plate, and both pipe ends (total width of a coupling body back from the pipe ends), as shown.

NOTE: Larger size coupling bodies are provided with a tapped boss. Install an eye bolt into this tapped boss to facilitate moving the coupling bodies.

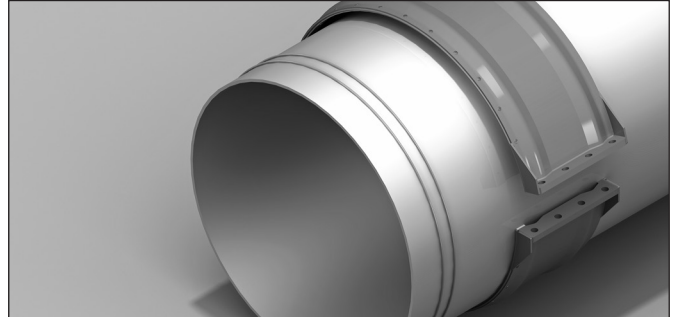

3. Slide the lubricated coupling body over one of the pipe ends, as shown above. **The side of the coupling body that contains the Teflon* shoulder must be installed toward the pipe end that contains the cladding.**

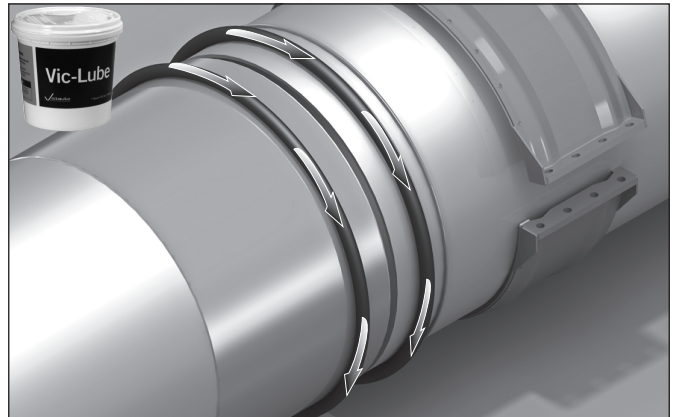

4. Position the smaller diameter o-ring over the lubricated pipe end of the expansion side (with cladding). Position the larger diameter o-ring between the restraint ring and lubricated pipe end on the fixed side. The o-rings are designed to fit tight and will require stretching to fit around the pipe diameter. Apply lubricant to the o-rings after than are placed on the pipe ends by lifting the o-rings and applying lubricant around the diameter. Place the bonded area of the o-rings away from the opening of the coupling body that is intended for the sealing plate location. Make sure all twists are removed from the o-rings.

4a. Align and bring the pipe ends into position. The gap between the pipe ends must be set appropriately for the installation temperature (refer to Victaulic publication 26.20 for details).

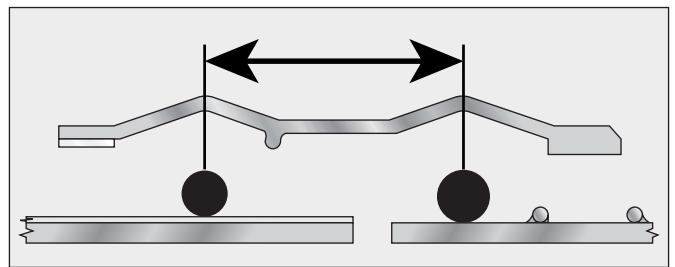

5. Measure the center-to-center distance between the arches. Position the center of the o-rings this measured distance apart around the entire pipe circumference, as shown above.

* TEFLON IS A REGISTERED TRADEMARK OF THE DUPONT COMPANY.

Victaulic® Style 231 Non-Restrained, Flexible Expansion Coupling with Cladding on Expansion Side of Pipe

ONE SEGMENT, TYPE 2

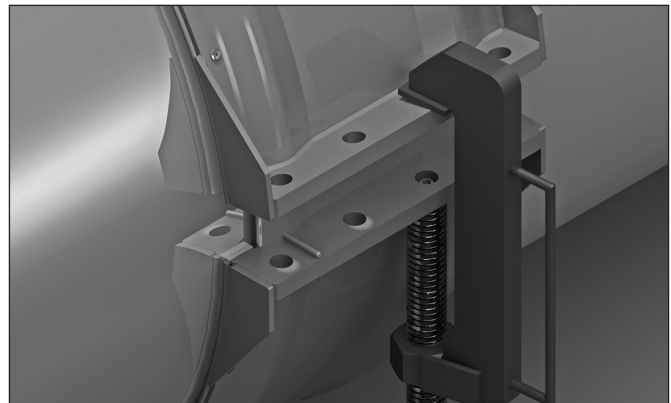
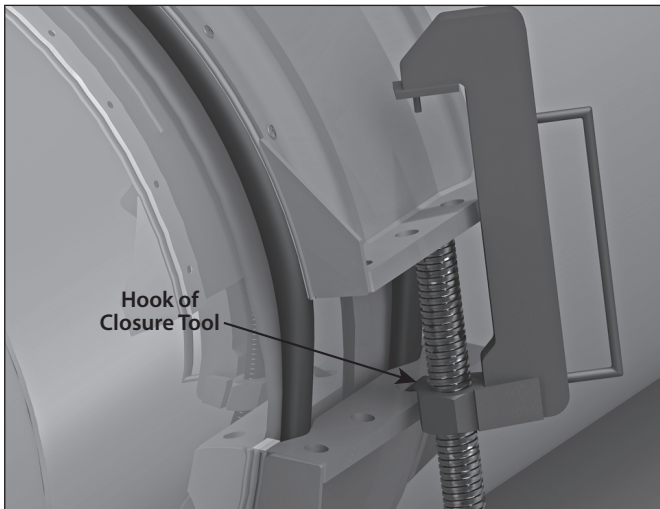

NOTICE

The closure tool can be used to spread the coupling body apart for positioning the coupling body over the pipe joint.

- Insert the hook of the closure tool into the center hole (or one of the center holes) of one closure plate. Pump the handle of the hydraulic hand pump to extend the cylinder so that the ram of the hydraulic closure tool contacts the other closure plate and spreads the coupling body apart. Position the coupling body over the pipe joint (refer to Step 6), and remove the closure tool when complete.

7. When an even number of closure plate holes exists, place the pin of the closure tool head into the center hole closer to the steel shoulder of the coupling body. Place the pin on the end of the hydraulic ram into the corresponding center hole of the other closure plate.

7a. Make sure the o-rings are seated in the arches by rotating the coupling body back and forth approximately 30° after partial tightening.

WARNING

- Make sure the closure tool engages with the closure plates properly (pins are aligned in holes).
- Keep hands and fingers away from pinch point areas when placing the closure tool onto the closure plates.
- Use caution to prevent damage to the rubber seals of the sealing plate.

Failure to follow these instructions could result in serious personal injury, joint leakage, and property damage.

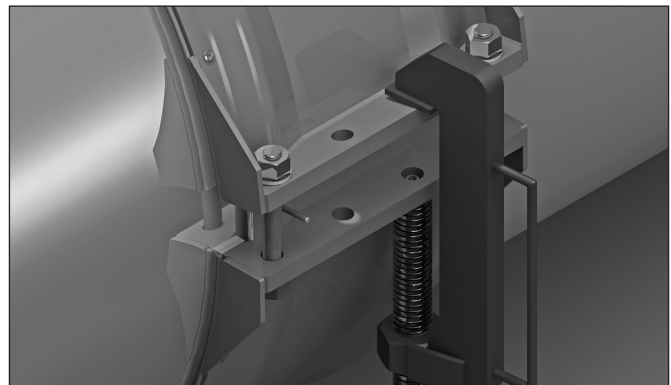
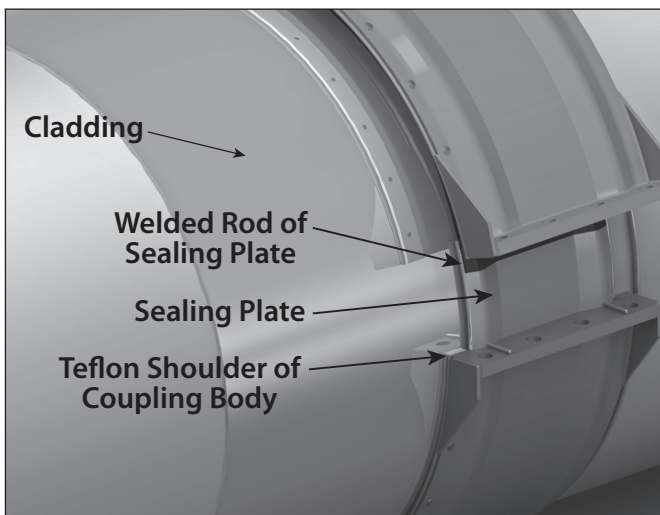

6. Position the coupling body over the pipe joint with the o-rings seated in the arches. Make sure the o-rings do not shift out of position.

6a. Insert the sealing plate, **with the pins facing out**, between the coupling body and o-rings, as shown above. **NOTE:** The Teflon spacer on the sealing plate must be installed toward the Teflon shoulder of the coupling body.

8. Slowly begin to close the coupling body with the closure tool, while making sure the sealing plate slides between the coupling body and the o-rings without bending or tearing.

8a. Continue closing the coupling body until a stud will fit through the holes of the closure plates, with enough space to install the washers and nuts. **NOTE:** The closure tool is not designed to pull the closure plates together completely.

8b. Apply lubricant (provided with the product) to the threads of all carbon steel studs. **NOTE:** Anti-seize lubricant is required for stainless steel fasteners. Insert studs with flat washers into the outside holes. Apply nuts and tighten until threads protrude. **Carbon steel installation hardware must be used, when provided with the product.**

Victaulic® Style 231 Non-Restrained, Flexible Expansion Coupling with Cladding on Expansion Side of Pipe

ONE SEGMENT, TYPE 2

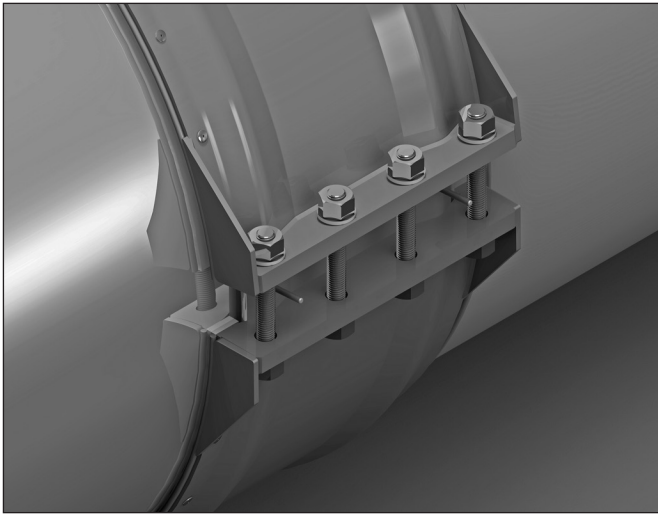

9. Remove the closure tool and insert a stud with flat washers and nuts into each of the remaining hole(s).

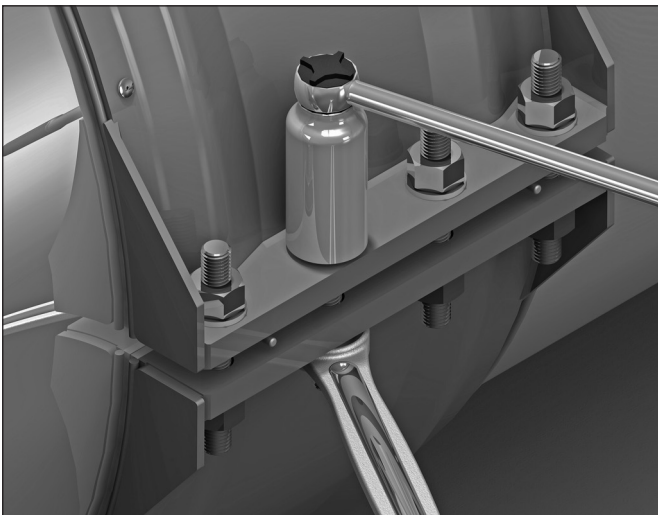

10. Finish closing the coupling body by tightening the fasteners gradually and evenly until the coupling body is in full contact with the pipe around its circumference. The closure plates should not contact each other.

10a. Refer to the table below for the maximum assembly torques that can be applied to various stud sizes. **DO NOT EXCEED THE TORQUE VALUES SPECIFIED IN THIS TABLE.**

Maximum Assembly Torque Values

Stud Size inches	Maximum Assembly Torque Value ft-lbs/N•m*	
	Carbon Steel Hardware	Stainless Steel Hardware
½	240	220
	325	298
¾	300	275
	407	373
¾	360	330
	488	447
7/8	425	320
	576	434
1	485	370
	658	502
1 1/8	550	330
	746	447
1 1/4	600	375
	814	509

* Applies to all coupling types

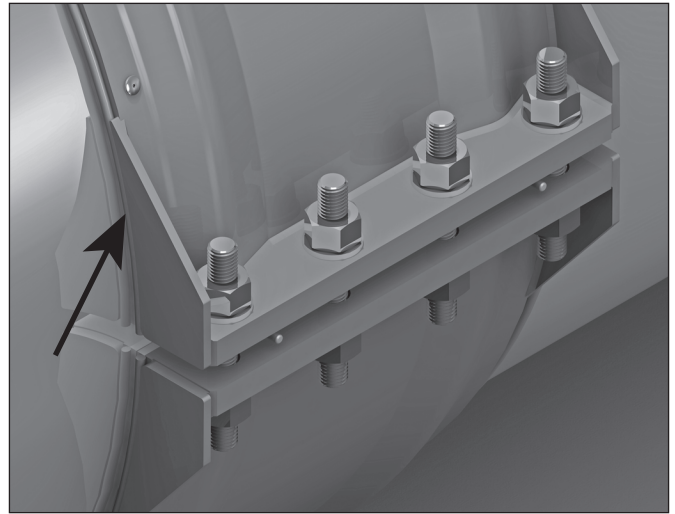

11. Proper assembly is achieved when the coupling body is in full contact with the pipe surface around the circumference of the pipe. However, a gap between the shoulder and the pipe is acceptable if it does not exceed 3/32 inch/2.4 mm and totals no more than 10% of the pipe circumference.

11a. If stainless steel hardware is required, follow the “Replacing Carbon Steel Installation Hardware” section for replacement steps.

NOTICE

- A gap will be present between the closure plates.

REPLACING CARBON STEEL INSTALLATION HARDWARE (WHEN SUPPLIED) WITH STAINLESS STEEL HARDWARE

If stainless steel hardware is required, it must be installed after proper assembly is achieved with the carbon steel installation hardware.

1. Apply a high-quality, anti-seize compound to the stainless steel studs to prevent seizing.
2. Remove the carbon steel hardware one at a time, and replace it with the stainless steel hardware. After all carbon steel hardware is replaced with stainless steel hardware, re-inspect the joint to ensure proper assembly, as described in step 11 of the “Installation” section.

Victaulic® Style 231 Non-Restrained, Flexible Expansion Coupling with Cladding on Expansion Side of Pipe

ONE SEGMENT, TYPE 2

For complete contact information, visit www.victaulic.com

I-231.T2S1/CLAD 6901 REV C UPDATED 12/2012 Z000231005

VICTAULIC IS A REGISTERED TRADEMARK OF VICTAULIC COMPANY. © 2012 VICTAULIC COMPANY. ALL RIGHTS RESERVED. PRINTED IN THE USA.

I-231.T2S1/CLAD

