

AWWA Check Valves

SERIES 317





WARNING

WARNING	
 	<ul style="list-style-type: none"> Read and understand all instructions before attempting to install, remove, adjust, or perform maintenance on any Victaulic piping products Wear safety glasses, hardhat, and foot protection. <p>Failure to follow these instructions could result in serious personal injury, property damage, joint leakage, and/or joint failure.</p>

AWWA Check Valves

SERIES 317

IMPORTANT INFORMATION

 WARNING	
	<ul style="list-style-type: none">• Always check for flow in the line before installing any accessory kits. If there is flow in the line, disable the system's pump, or isolate the valve before installing any accessories. The lever will elevate when there is flow in the line.
<p>Failure to follow these instructions could result in serious personal injury and/or property damage.</p>	

VALVE INSTALLATION

1. Remove plastic from valve ends.
2. Valve ends and pipe ends must be smooth and free from deep pits and swells. All rust, loose scale, oil, grease, and dirt must be removed. Verify that pipe groove dimensions are within Victaulic specifications for ductile iron pipe.
3. Make sure there is suitable clearance for proper operation of the lever and any accessories.
4. **THE ARROW ON THE VALVE BODY MUST CORRESPOND WITH THE DIRECTION OF THE FLOW IN THE LINE.**
5. Install the valve into the piping system by using Victaulic Style 31, 307, or 341 couplings. Refer to the installation information provided with the coupling for complete instructions.

VALVE OPERATION

- The Series 317 Check Valve will open as upstream pressure overcomes the pressure on the downstream side of the disc. The valve will close as pressure equalizes or when pressure on the downstream side of the disc overcomes the upstream pressure.
NOTE: The valve should not be operated manually.
- Make sure there is no interference with the operation and range of motion of external accessories.

AWWA Check Valves

SERIES 317

VALVE ADJUSTMENT

WARNING	
	<ul style="list-style-type: none"> • Depressurize and drain the piping system before adjusting any Victaulic piping products.
<p>Failure to follow this instruction could result in serious personal injury and/or property damage.</p>	

NOTICE
<ul style="list-style-type: none"> • The Series 317 Check Valve should not require adjustment under normal operating conditions.

1. For the adjustment of valve accessories, refer to the "Accessory Kit Installation" section, starting on page 8.



2. To adjust packing box sealing, tighten the packing nut until leakage stops. DO NOT exceed 20 ft-lbs (27 N•m) on the packing nut. If the packing fails to seal, replace the packing by following the "Maintenance" section, starting on this page.

MAINTENANCE

WARNING	
	<ul style="list-style-type: none"> • Depressurize and drain the piping system before attempting to perform maintenance or adjustments on any Victaulic piping products.
<p>Failure to follow this instruction could result in serious personal injury and/or property damage.</p>	

PACKING REPLACEMENT

1. Depressurize and drain the system to remove the valve from service.
2. Remove any accessories from the valve.

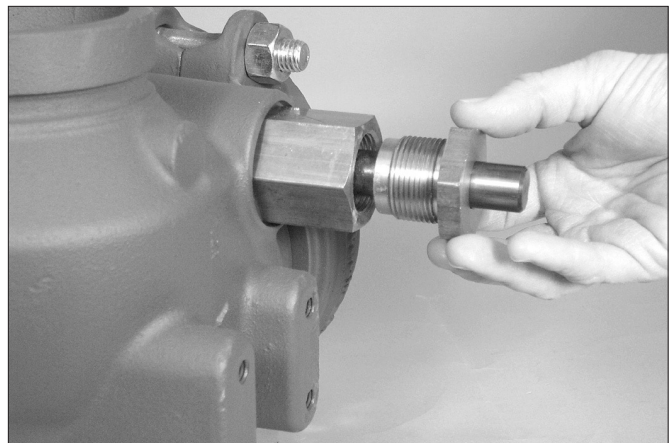

3. Remove the packing nut.

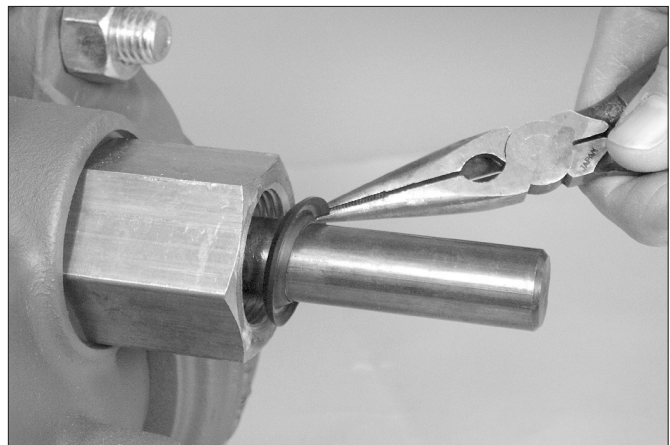

4. Remove and discard the old packing (four pieces).

AWWA Check Valves

SERIES 317

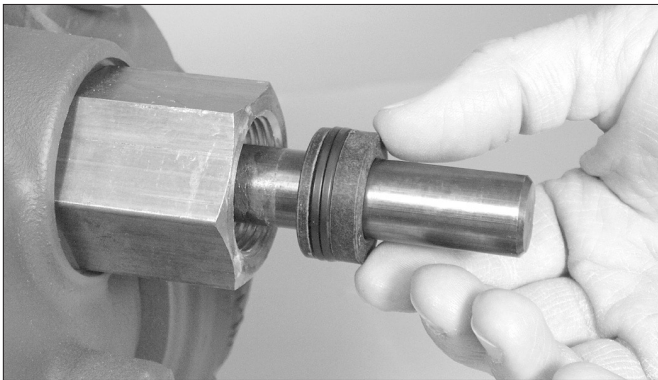
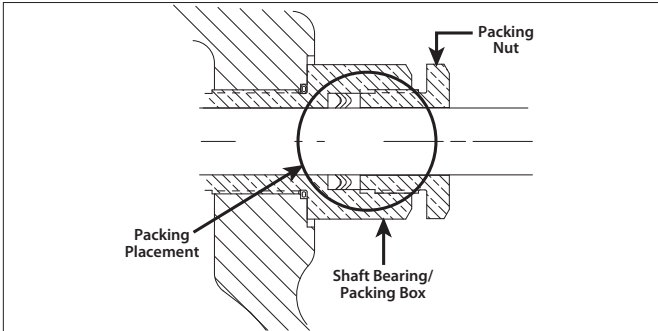

5. Stack the NEW packing together (one male, two v-rings, one female). Slide the packing over the hinge shaft and into the packing box.

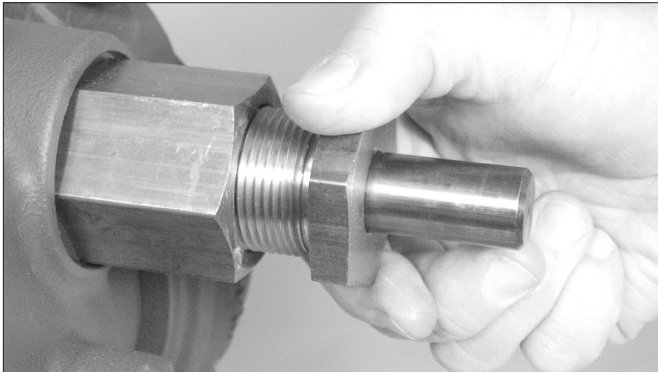

6. Replace the packing nut. Tighten the packing nut to a torque of 10 – 15 ft-lbs (14 – 20 N•m). DO NOT exceed 20 ft-lbs (27 N•m).

7. Re-install any accessories by following the steps in the appropriate section of the “Accessory Kit Installation” section, starting on page 8.

O-RING AND PACKING REPLACEMENT

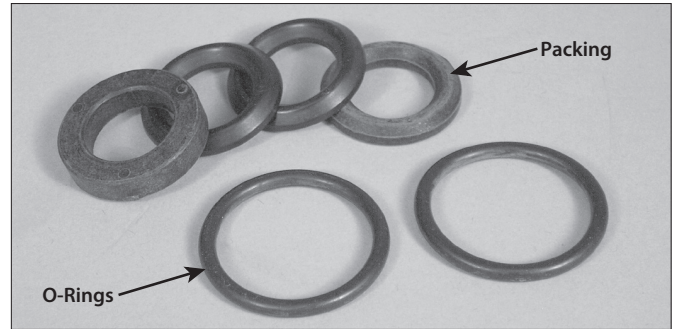

If leakage past the shaft bearings occurs, the o-rings and packing must be replaced.

⚠ WARNING

- Depressurize and drain the piping system before attempting to perform maintenance or adjustments on any Victaulic piping products.

Failure to follow this instruction could result in serious personal injury and/or property damage.

1. Depressurize and drain the system to remove the valve from service.
2. Remove any accessories from the valve.

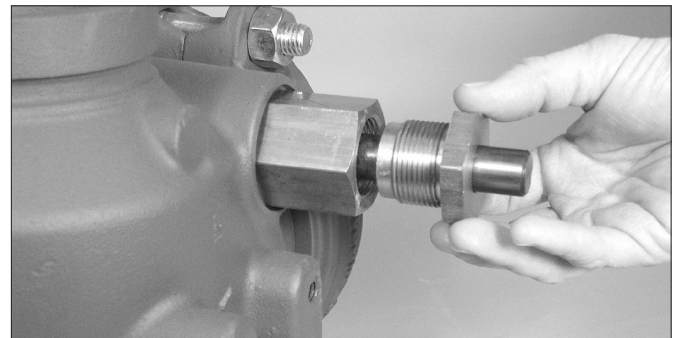
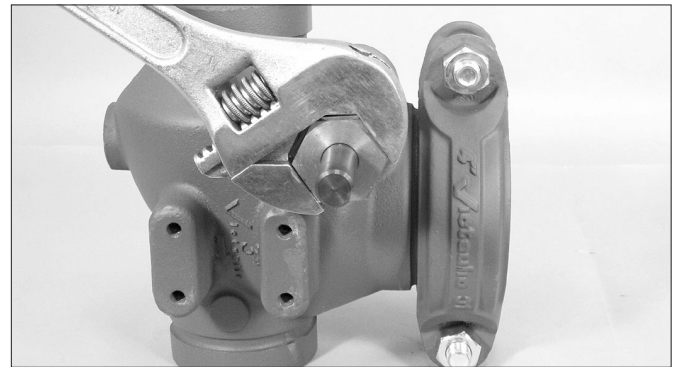

3. Remove the packing nut.

AWWA Check Valves

SERIES 317

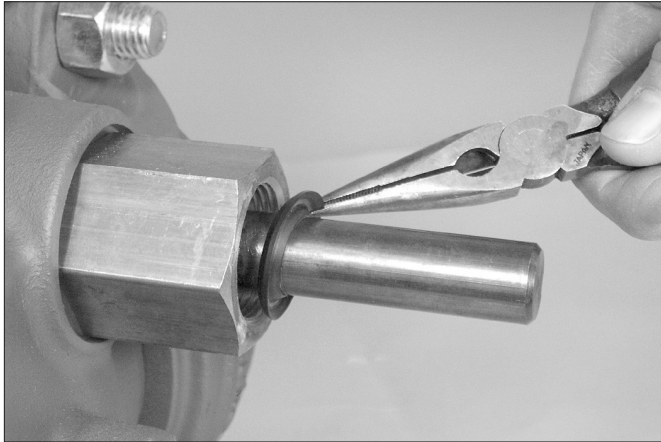

4. Remove and discard the old packing (four pieces).

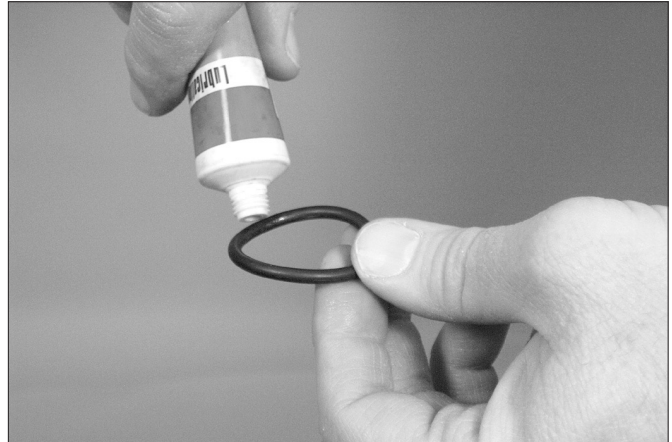

8. Lubricate the NEW o-ring with silicone grease.

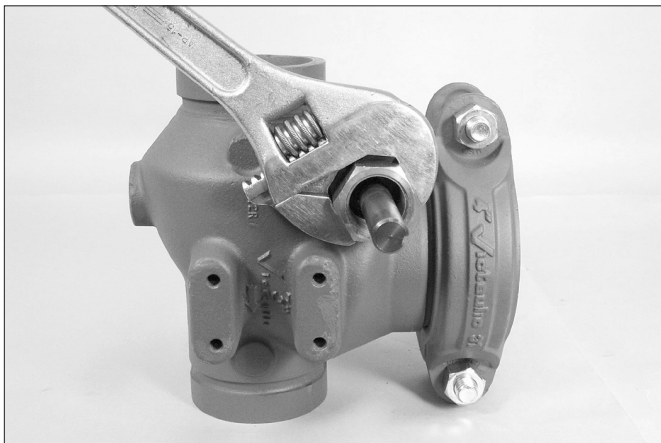

5. Remove the shaft bearing/packing box from the valve. Be careful not to damage the hinge shaft.



9. Install the NEW o-ring onto the bearing. Make sure the o-ring is pushed all the way down against the bearing.



6. Remove and discard the old o-ring from the bearing.

7. Clean the bearing with water.



10. Apply a non-permanent, thread-locking compound onto the first two threads of the bearing.

11. Slide the bearing back onto the shaft, and tighten until snug. DO NOT tighten the bearing completely or insert the packing at this time.

AWWA Check Valves

SERIES 317



12. Remove the bearing from the opposite side of the valve. Be careful not to damage the hinge shaft.

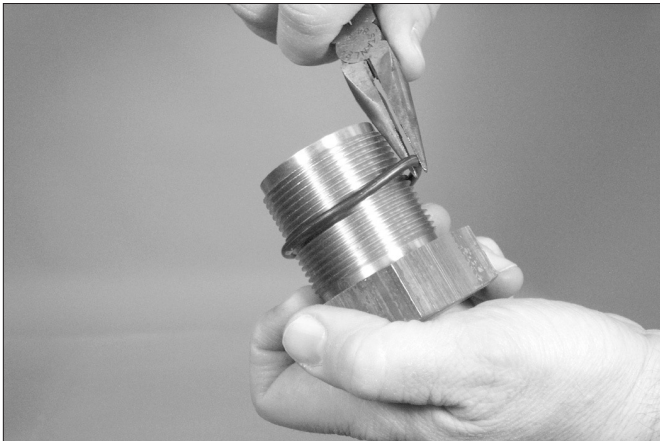

13. Remove and discard the old o-ring from the bearing.

14. Clean the bearing with water.



15. Lubricate the NEW o-ring with silicone grease.



16. Install the NEW o-ring onto the bearing. Make sure the o-ring is pushed all the way down against the bearing.

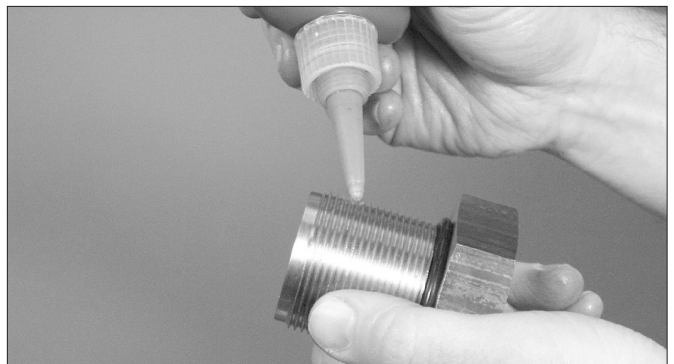

17. Apply a non-permanent, thread-locking compound onto the first two threads of the bearing.

18. Align the bearing with the hinge shaft, and thread the bearing into position.

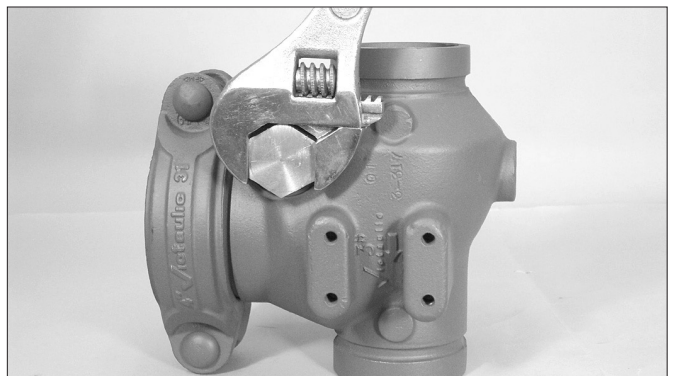

19. Tighten the two bearings to a torque of 100 – 150 ft-lbs (136 – 203 N•m).

AWWA Check Valves

SERIES 317

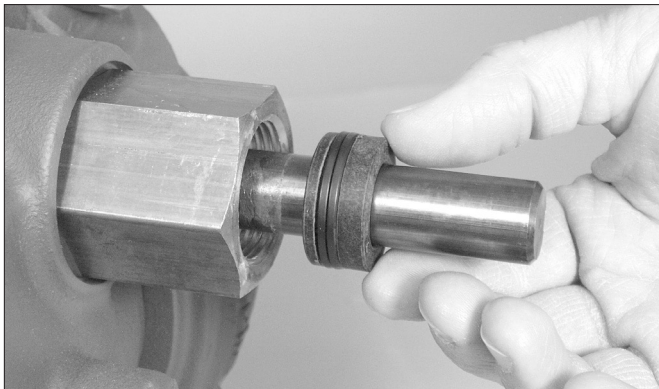
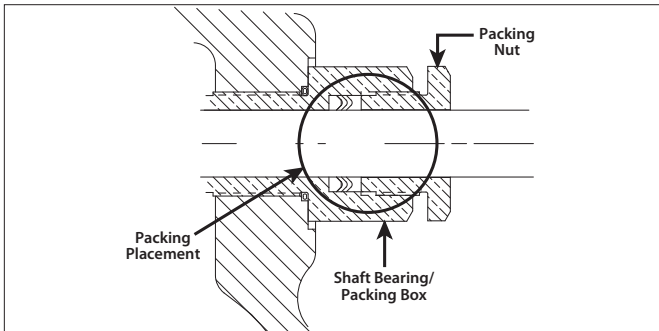

20. Stack the new packing together (one male, two v-rings, one female). Slide the packing over the hinge shaft and into the packing box.

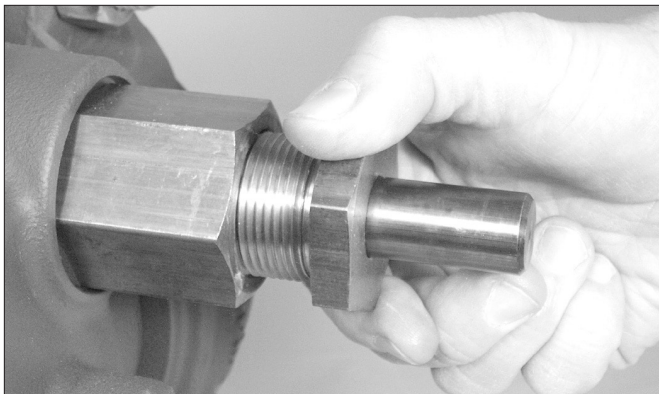

21. Replace the packing nut. Tighten the packing nut to a torque of 10 – 15 ft-lbs (14 – 20 N•m). DO NOT exceed 20 ft-lbs (27 N•m).

22. Re-install any accessories by following the steps in the appropriate section of the “Accessory Kit Installation” section, starting on page 8.

CLEANING

⚠ WARNING	
	<ul style="list-style-type: none"> • Depressurize and drain the piping system before attempting to perform maintenance or adjustments on any Victaulic piping products.
<p>Failure to follow this instruction could result in serious personal injury and/or property damage.</p>	

1. Depressurize and drain the system to remove the valve from service.



2. Loosen and remove the two bolts/nuts from the top access coupling.



3. Remove the top access coupling.



4. Remove the gasket and the top access cap. If the gasket is torn or worn, replace it with a new, Victaulic-supplied gasket of the same grade.

AWWA Check Valves

SERIES 317

5. Remove any debris from inside the valve body.



6. If reusing the same gasket, make sure the gasket is free of any dirt. Lubricate the gasket with Victaulic lubricant.



7. Install the gasket onto the valve. Make sure the gasket lip does not overhang the end of the valve.



8. Install the top access cap onto the valve. Center the gasket to cover both sealing areas of the cap and the valve.

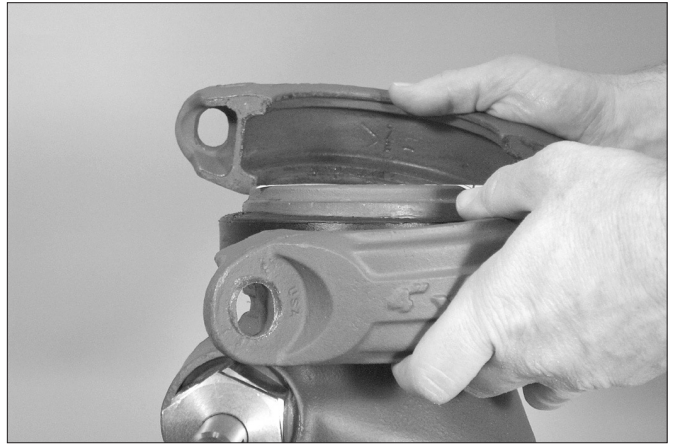

9. Install the coupling housings over the gasket. Make sure the housings' keys engage properly with the valve body and the top access cap.



10. Insert the bolts, and apply the nuts finger-tight. Make sure the bolt track heads seat properly in the bolt holes.

- 10a. Tighten the nuts evenly by alternating sides until metal-to-metal contact occurs at the bolt pads. **NOTE:** It is important to tighten the nuts evenly to prevent gasket pinching.

AWWA Check Valves

SERIES 317

ACCESSORY KIT INSTALLATION

WARNING



- Depressurize and drain the piping system before attempting to perform maintenance or adjustments on any Victaulic piping products.

Failure to follow this instruction could result in serious personal injury and/or property damage.

WARNING



- Always check for flow in the line before installing any accessory kits.
- If there is flow in the line, disable the system's pump, or isolate the valve before installing any accessories.
- The valve's arm will elevate when there is flow in the line.

Failure to follow these instructions could result in serious personal injury and/or property damage.

The following is a listing of proper installation orientations for the Series 317 Check Valve.

Option ¹	Horizontal Orientation	Vertical Orientation
Bare	Yes	Yes
Lever with Weight	Yes	Yes ²
Lever with Spring	Yes	Yes
Lever with Adjustable Spring ³ and Air Cushion	Yes	Yes

1. Valves installed without air cushions are subject to slamming.
2. For proper operation in vertical installations, the lever must be rotated 90° (refer to instructions on page 8).
3. All valves installed with an air cushion must also contain an adjustable spring. **NOTE:** This is not the same spring that is provided with non-air cushion options.

LEVER WITH WEIGHT (HORIZONTAL INSTALLATIONS)

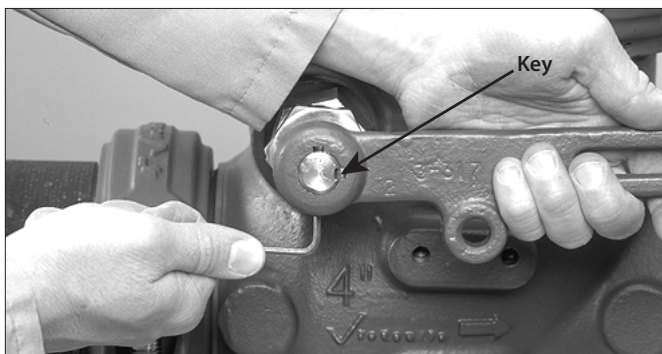

1. Insert the key into the keyway in the shaft. Install the lever onto the shaft by aligning the keyway in the lever with the key in the shaft. Tighten the set screw by using an allen wrench.

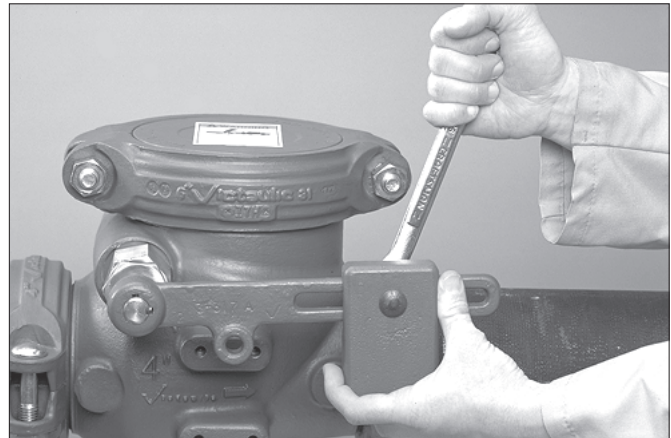

2. Slide the weight to the desired location on the lever. Install a flat washer and nut onto the bolt. Tighten the nut to secure the weight in position.

LEVER WITH WEIGHT (VERTICAL INSTALLATIONS)

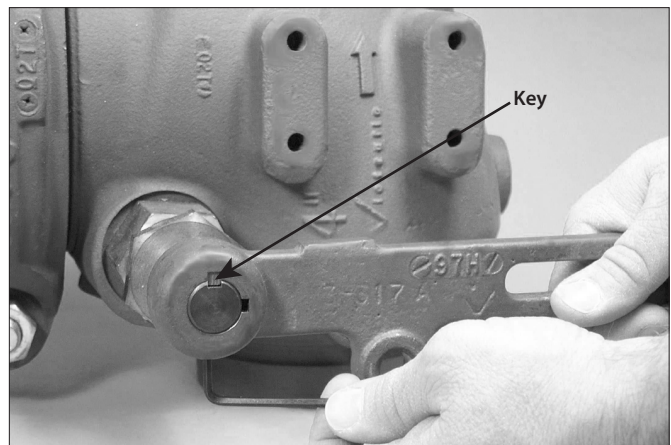
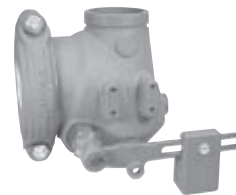

1. Insert the key into the keyway in the shaft, as shown above. Install the lever onto the shaft by aligning the keyway in the lever with the key in the shaft. **NOTE: The flow arrow must be pointing upward, and the lever must be installed in the orientation shown above.** Tighten the set screw by using an allen wrench.

AWWA Check Valves

SERIES 317

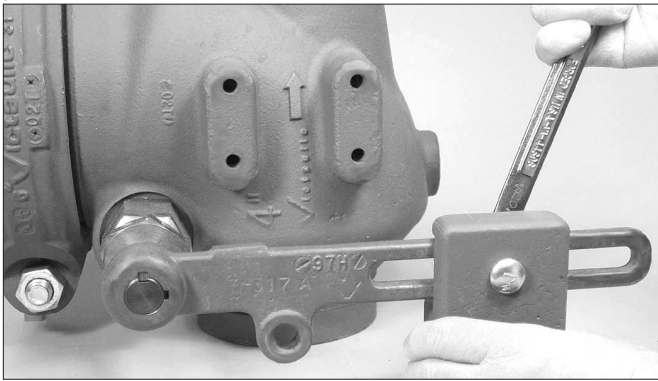

- Slide the weight to the desired location on the lever. Install a flat washer and nut onto the bolt. Tighten the nut to secure the weight in position.

LEVER WITH SPRING

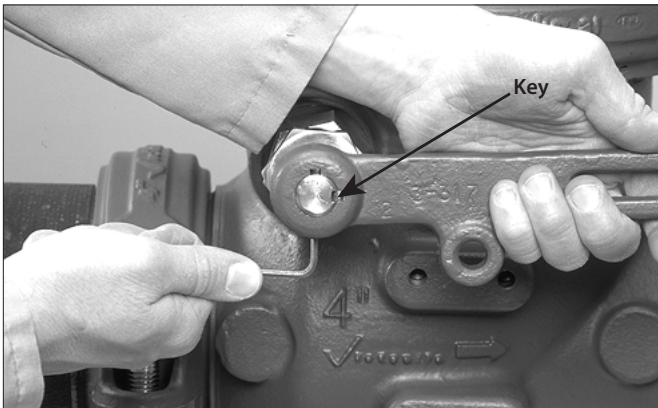

- Insert the key into the keyway in the shaft. Install the lever onto the shaft by aligning the keyway in the lever with the key in the shaft. Tighten the set screw by using an allen wrench.



- Install a nut onto the end of the eye bolt. Thread the eye bolt into the tapped hole furthest from the shaft, as shown above.



- Tighten the nut to secure the eye bolt.

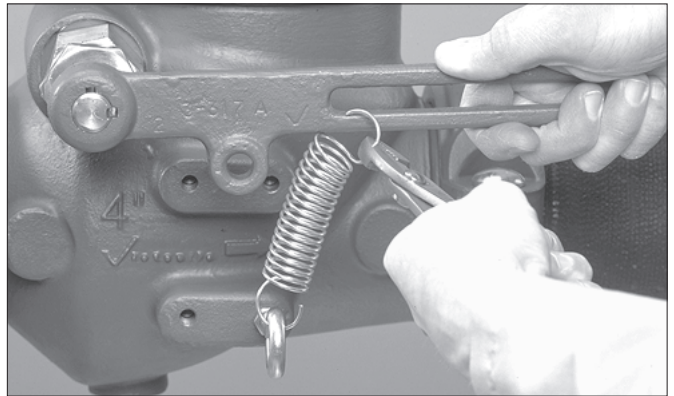

- Install the spring by looping one end over the eye bolt and the other end through the slot in the lever.

LEVER WITH SPRING AND AIR CUSHION

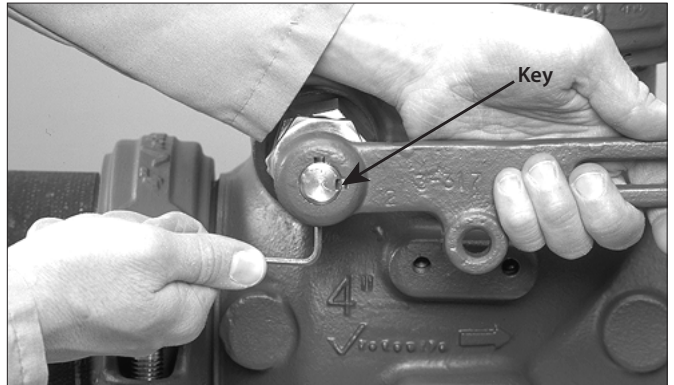

- Insert the key into the keyway in the shaft. Install the lever onto the shaft by aligning the keyway in the lever with the key in the shaft. Tighten the set screw by using an allen wrench.

AWWA Check Valves

SERIES 317

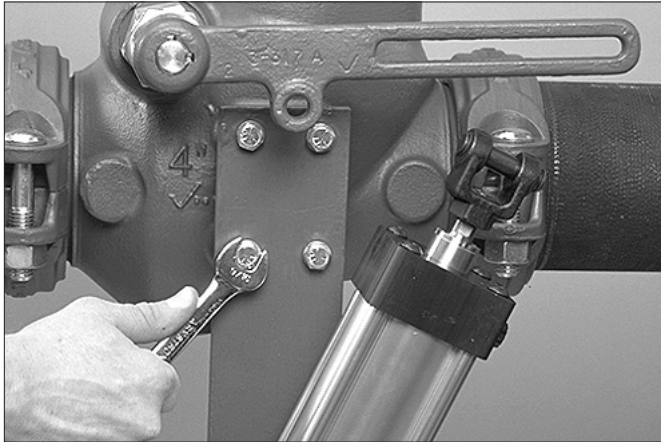

2. Install the bracket with four bolts and lock washers. Tighten the bolts until the lock washers are fully compressed.

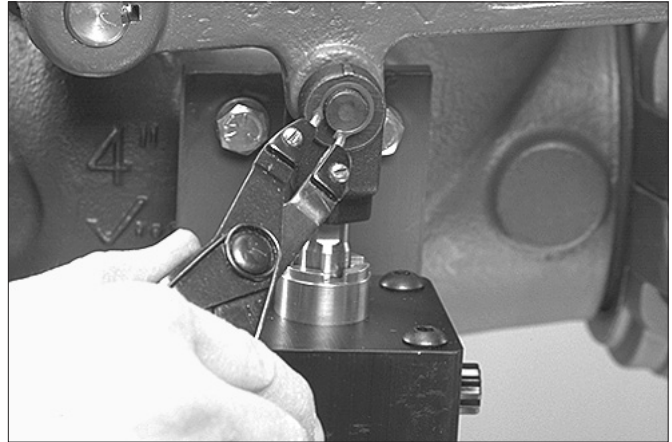

5. Re-install the retaining rings onto the ends of the pivot pin.

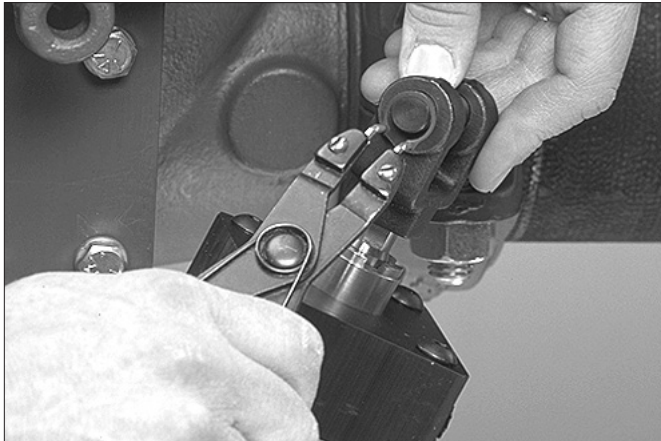

3. Remove the retaining rings from the ends of the pivot pin. Remove the pivot pin.

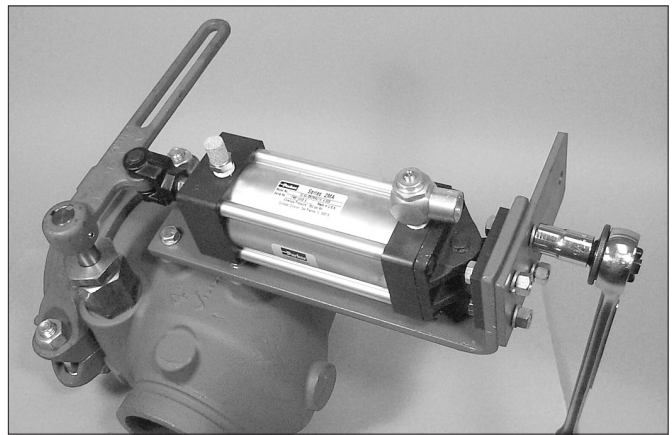

6. Install the spring plate parallel to the lever, as shown above. Place one lock washer and a nut onto the end of each bolt. Tighten the nut until the lock washer is fully compressed.

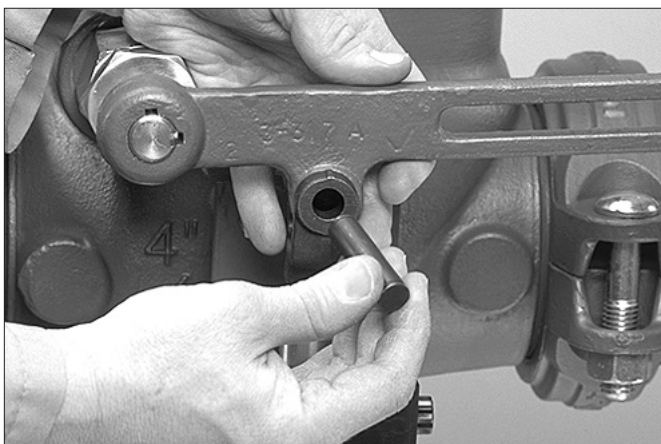

4. Secure the clevis of the air cushion to the lever by inserting the pivot pin.

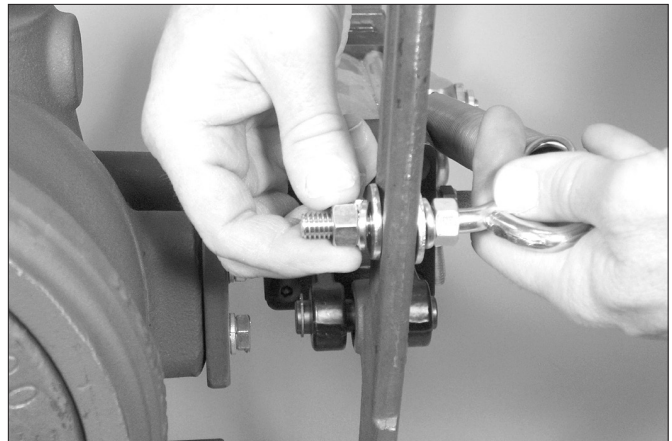

7. Install a nut, then a lock washer, then a flat washer onto one of the eye bolts. Place the eye bolt through the slot in the lever. On the end of the eye bolt, install a flat washer, a lock washer, and a nut (as shown above).

AWWA Check Valves

SERIES 317



8. Tighten the nut to secure the spring assembly to the lever.

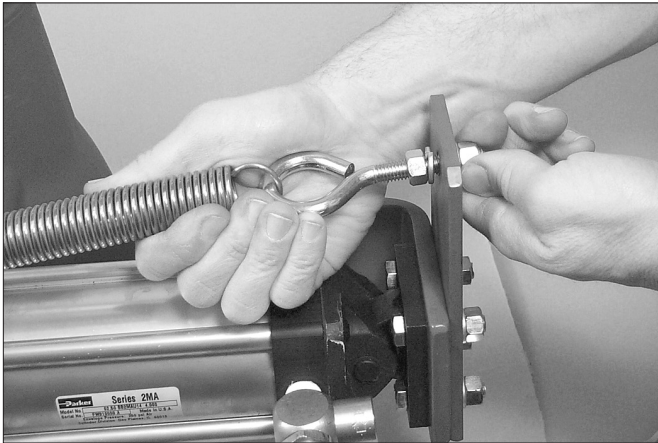

9. Install a nut then a lock washer onto the opposite eye bolt. Pull the spring toward the spring plate, as shown above. Install a lock washer onto the end of the eye bolt. Hand-tighten a nut onto the end of the eye bolt.

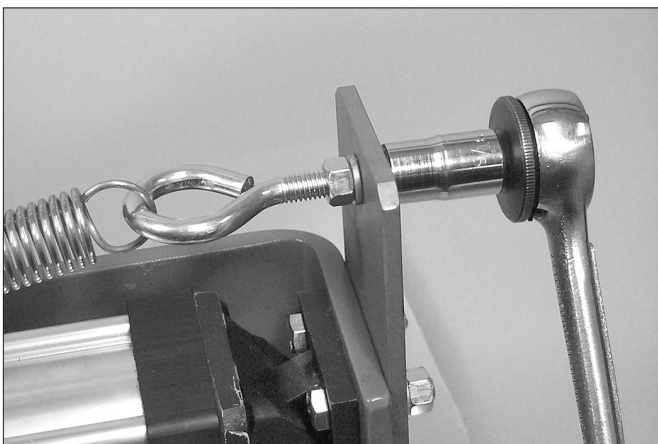

10. To secure the spring assembly to the spring plate, tighten the nut until the lock washers are fully compressed.

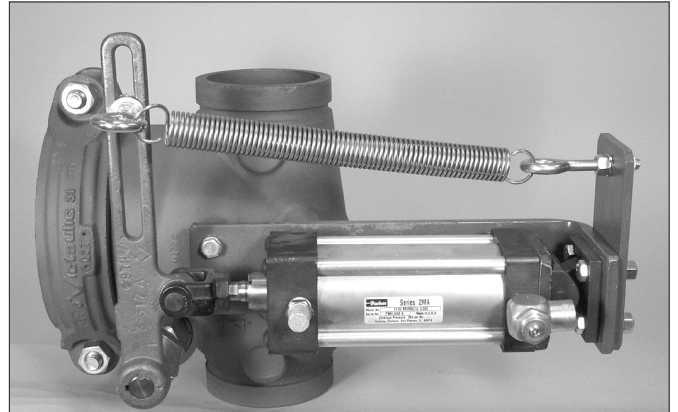

11. Adjust the spring to the desired tension by changing the position of the eye bolt in the slot of the lever.

ADJUSTING THE AIR CUSHION

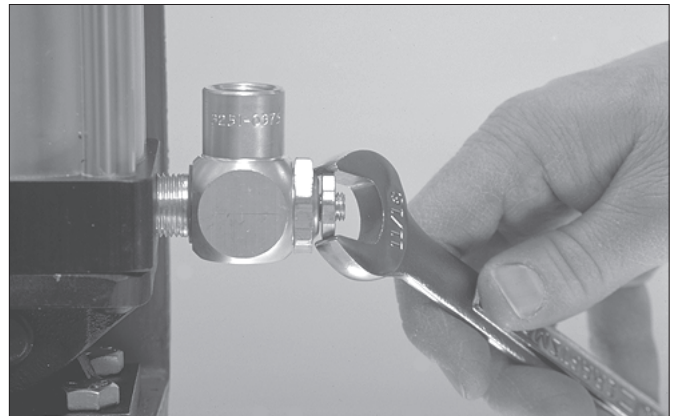

1. Loosen the locking nut on the flow control valve.

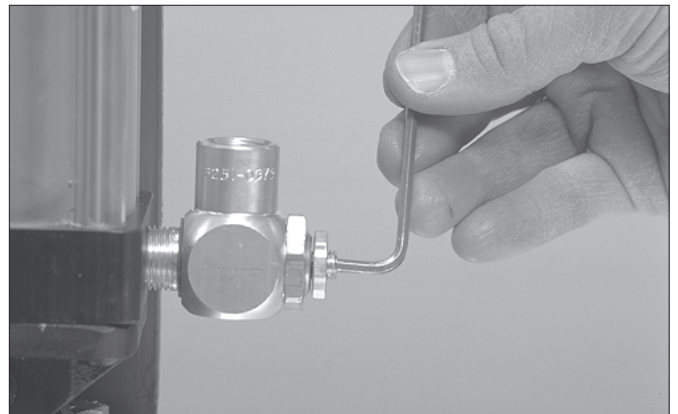

2. Adjust the flow control valve to the desired level of cushion. Turn the flow control valve clockwise to increase the amount of cushion or counterclockwise to decrease the amount of cushion.

⚠ CAUTION

- Never close the flow control valve fully (by turning clockwise). Failure to follow this instruction could cause damage to the valve, resulting in property damage.

AWWA Check Valves

SERIES 317

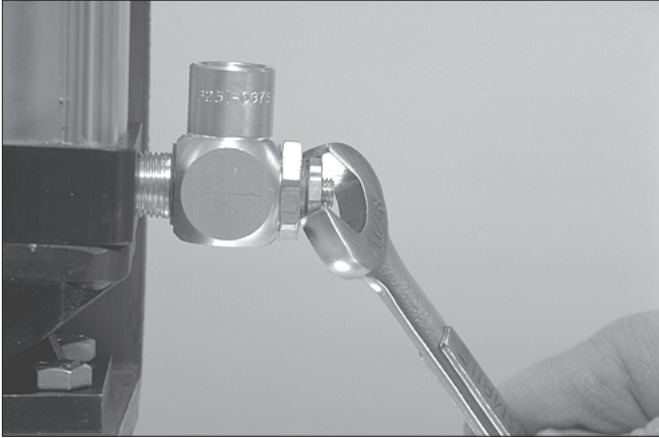

3. Tighten the locking nut on the flow control valve.

AWWA Check Valves

SERIES 317

REPLACEMENT PARTS

Part Description	Quantity	Valve Size - inches/millimeters					
		3 (100,6)	4 (121,9)	6 (175,3)	8 (229,9)	10 (281,9)	12 (335,3)
Packing	1 Set	P030317TPK	P030317TPK	P030317TPK	P080317TPK	P080317TPK	P080317TPK
O-Ring	2	P21825215T	P21825215T	P21825215T	P22325215T	P22325215T	P22325215T

TROUBLESHOOTING

Reported Condition	Corrective Action
Seat leakage	<ul style="list-style-type: none"> Flush the valve to clean the seat. Depressurize and drain the system. Remove the access cap for visual examination, and clean the internal parts (refer to the "Cleaning" section, starting on page 6, for instructions). Check the Victaulic Series 317 submittal to ensure that any accessory options are appropriate for the valve's installation orientation. Contact Victaulic for additional assistance.
Shaft leakage	<ul style="list-style-type: none"> Tighten the packing nut (refer to the "Valve Adjustment" section on page 2 for instructions). Replace the packing (refer to the "Packing Replacement" and "O-Ring and Packing Replacement" sections, starting on page 2, for instructions). Contact Victaulic for additional assistance.
Shaft does not operate smoothly	<ul style="list-style-type: none"> Excessive tightening of the packing nut is causing too much friction. Re-adjust the packing nut by following step 2 of the "Valve Adjustment" section on page 2.

AWWA Check Valves

SERIES 317

For complete contact information, visit www.victaulic.com

I-317 2231 REV D UPDATED 05/2003 Z000317001

VICTAULIC IS A REGISTERED TRADEMARK OF VICTAULIC COMPANY. © 2003 VICTAULIC COMPANY. ALL RIGHTS RESERVED. PRINTED IN THE USA.

I-317

