

SERIES 751 FIRELOCK™ EUROPEAN ALARM CHECK VALVE STATIONS WITH "SBSC" TRIM

THIS WALL CHART IS A GUIDE FOR PLACING THE SYSTEM IN SERVICE AND FOR PERFORMING REQUIRED WATER FLOW ALARM TESTS.

AN EXPERIENCED, TRAINED INSTALLER SHALL READ AND UNDERSTAND THE FULL CONTENTS OF THE INSTALLATION, MAINTENANCE, AND TESTING MANUAL AND ALL WARNING MESSAGES BEFORE ATTEMPTING TO PLACE THE SYSTEM INTO SERVICE.

INITIAL SYSTEM SETUP

Step 1:

Open the system main drain valve (Item 13). Confirm that the system is drained.

Step 2:

Close the system main drain valve (Item 13).

Step 3:

Confirm that system drains are shut and the system is free of leaks.

Step 3a:

Confirm that the system has been depressurized. The gauges should indicate zero pressure.

Step 4:

Open the remote system test valve (inspector's test connection) and any auxiliary drains to remove all air from the system.

Step 5:

Close the alarm line monitoring ball valve (Item 9a) to prevent alarms from operating while the system is filling. Alarm and electrical panels (controlled by an alarm flow switch on the riser) cannot be interrupted. **NOTE:** If alarm activation is possible, notify local fire companies that the system is being serviced.

Step 6:

Open the water supply main control valve (Item 3) slowly.

Step 7:

Allow the system to fill with water completely. Allow water to flow from the remote system test valve (inspector's test connection) and any auxiliary drains until all trapped air is removed from the system.

Step 8:

After a steady flow of water is established and all air is released from the system, close the remote system test valve (inspector's test connection) and any auxiliary drains in the system.

Step 9:

Record the system pressures. The system pressure gauge (Item 7) should be equal to or greater than the water supply pressure gauge (Item 5).

Step 10:

Open the water supply main control valve (Item 3) fully.

Step 11:

Open the alarm line monitoring ball valve (Item 9a).

Step 12:

Confirm that all valves are in their normal operating positions (refer to table below).

Step 13:

Notify the authority having jurisdiction, remote station alarm monitors, and those in the affected area that the system is in service.

NORMAL OPERATING POSITIONS FOR VALVES

Valve	Normal Operating Position
Alarm Line Monitoring Ball Valve	Open
Water Supply Main Control Valve	Open

Valve	Normal Operating Position
System Main Drain Valve	Closed
System Test Valve	Closed

Gray shaded areas identify components that are provided standard when the "SBSC" trim configuration is ordered.

Orange shaded areas identify components that are optional equipment.

Item	Description
1	Series 751 FireLock European Alarm Check Valve
2	FireLock Rigid Coupling
3	Water Supply Main Control Valve
4	Gauge Valve
5	Water Supply Pressure Gauge
6	Drain Swing Check Valve
7	System Pressure Gauge
8	Restricted Orifice/Alarm Line Drain
9	Alarm Line Monitoring Limit Switch Assembly
9a	Alarm Line Monitoring Ball Valve
10	Alarm Pressure Switch
11	Restrictor
12	System Test Valve
13	System Main Drain Valve

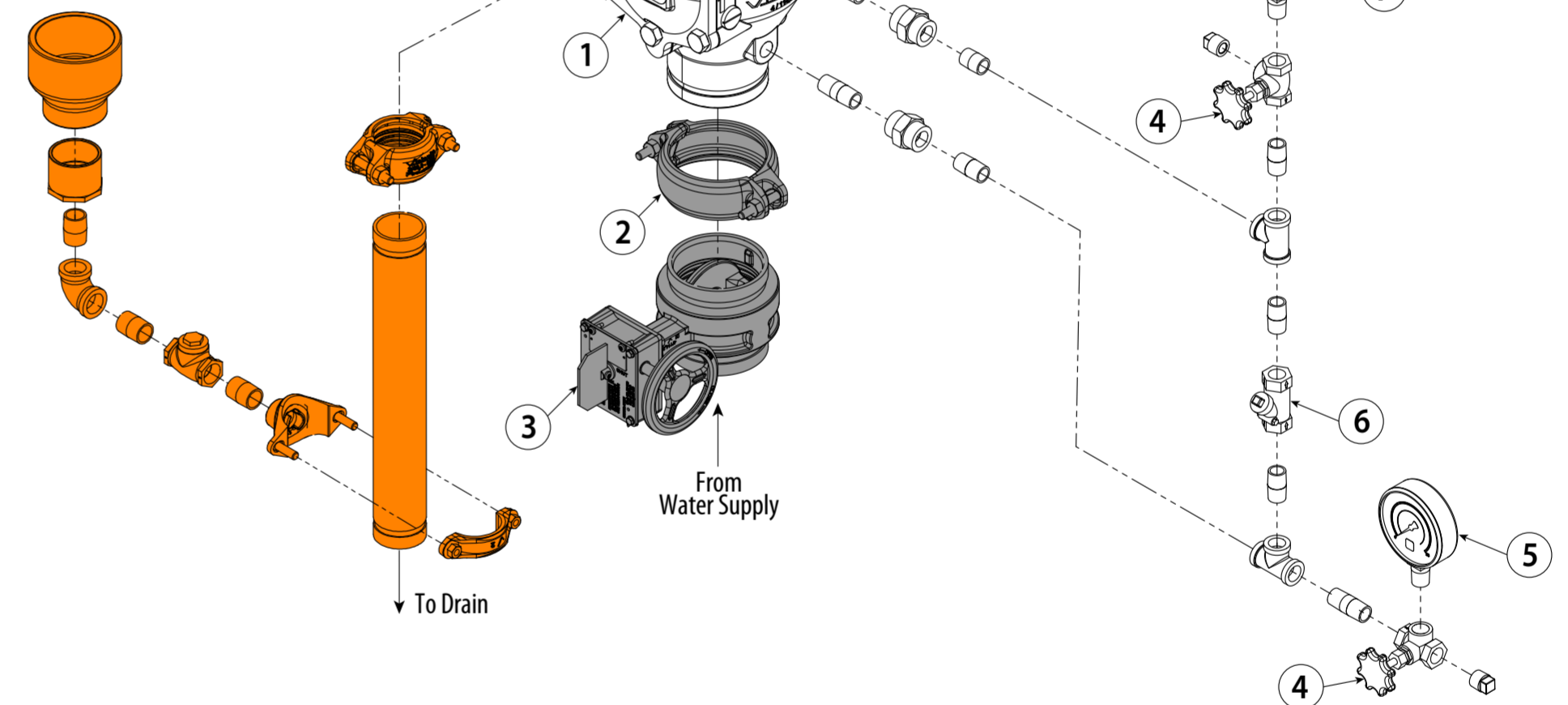

REQUIRED WATER FLOW ALARM TEST

Perform the water flow alarm test on a frequency required by national standards. In addition, the authority having jurisdiction in the area may require these tests on a more frequent basis. Verify these requirements by contacting the authority having jurisdiction in the affected area.

1. Notify the authority having jurisdiction, remote station alarm monitors, and anyone in the affected area that the water flow alarm test will be performed.
2. Verify that the alarm line monitoring ball valve (Item 9a) is open.
3. Open the system test valve (Item 12) fully. Confirm that mechanical and electrical alarms are activated and that remote monitoring stations, if provided, receive an alarm signal.
4. Close the system test valve (Item 12) after proper operation of all alarms is verified.
5. Verify that all alarms stopped sounding, that the alarm line drained properly, and that remote station alarms reset properly.
6. Push in the plunger of the restricted orifice/alarm line drain (Item 8).
- 6a. Verify that water is not flowing from the restricted orifice/alarm line drain (Item 8).
7. Notify the authority having jurisdiction, remote station alarm monitors, and those in the affected area that the valve is back in service.
8. Provide test results to the authority having jurisdiction, if required.