

# FireLock® European Dry Valve Stations

SERIES 756  
WITH SERIES 776 LOW-PRESSURE ACTUATOR

HANG THESE INSTRUCTIONS ON THE  
INSTALLED VALVE FOR EASY FUTURE REFERENCE



CE  
0786

VdS

WARNING



## WARNING



- Failure to follow instructions and warnings can cause product failure, resulting in serious personal injury and property damage.
- Read and understand all instructions before attempting to install any Victaulic piping products.
- Wear safety glasses, hardhat, and foot protection.
- Save this installation, maintenance, and testing manual for future reference.

If you need additional copies of any literature, or if you have any questions concerning the safe installation and operation of this product, contact Victaulic, Prijkelaar 36, 9810 Nazareth, Belgium, Phone: 32-9-381-1500.

DISCONTINUED PRODUCT

# FireLock® European Dry Valve Stations

**SERIES 756  
WITH SERIES 776 LOW-PRESSURE ACTUATOR**

## TABLE OF CONTENTS

Hazard Identification . . . . . 1

Installer Safety Instructions . . . . . 2

    General . . . . . 2

    Maintenance and Testing . . . . . 2

Introduction . . . . . 3

Trim Dimensions . . . . . 3

Exploded View Drawing – Trim Components . . . . . 4

Exploded View Drawing – Internal Valve Components . . . . . 5

Section View Drawing and Description –  
    Series 776 Low-Pressure Actuator . . . . . 6

Section View Drawing and Description –  
    Series 746-LPA Dry Accelerator . . . . . 7

Air Supply Requirements . . . . . 8

    Compressor Sizing . . . . . 8

    Base or Riser-Mounted Air Compressors . . . . . 8

    Shop Air or Tank-Mounted Air Compressors . . . . . 8

    Vicaltic Series 757 Regulated Air Maintenance  
        Trim Assembly (AMTA) . . . . . 8

    Vicaltic Series 757P Air Maintenance Trim  
        Assembly (AMTA) with Pressure Switch . . . . . 8

    Compressor Requirements and Settings for  
        Series 756 FireLock Dry Valves Installed with  
        Series 746-LPA Dry Accelerators . . . . . 9

    Settings for Air Supervisory Pressure Switches and  
        Alarm Pressure Switches . . . . . 9

    Remote System Test Valve Requirements . . . . . 9

Important Installation Information . . . . . 9

Valve/Trim Installation . . . . . 10

Hydrostatic Testing . . . . . 10

Placing the System in Service . . . . . 11

External Inspection . . . . . 16

    Weekly Inspection . . . . . 16

    Monthly Inspection . . . . . 16

Required System Tests . . . . . 17

    Water Flow Alarm Test . . . . . 17

    Water Level and Low Air Alarm Tests . . . . . 18

Required Operational (Trip) Tests . . . . . 21

    Partial Operational (Trip) Test . . . . . 21

    Full Operational (Trip) Test . . . . . 22

Required Internal Inspection . . . . . 24

Maintenance . . . . . 26

    Removing and Replacing the Clapper Seal . . . . . 26

    Removing and Replacing the Clapper Assembly . . . . . 28

    Installing the Cover Plate Gasket and Cover Plate . . . . . 29

    Removing and Replacing the Piston Assembly . . . . . 30

    Replacing the Strainer Screen for  
        Series 776 Low-Pressure Actuators . . . . . 30

Troubleshooting – Series 776 Low-Pressure Actuator . . . . . 31

Troubleshooting – Series 746-LPA Dry Accelerator . . . . . 31

Troubleshooting – System . . . . . 31

Facilities Location . . . . . B/C

## HAZARD IDENTIFICATION



Definitions for identifying the various hazard levels are provided below. When you see this symbol, be alert to the possibility of personal injury. Carefully read and fully understand the message that follows.

**WARNING**

- The use of the word “WARNING” identifies the presence of hazards or unsafe practices that could result in death or serious personal injury if instructions, including recommended precautions, are not followed.

**CAUTION**

- The use of the word “CAUTION” identifies possible hazards or unsafe practices that could result in personal injury and product or property damage if instructions, including recommended precautions, are not followed.

**NOTICE**

- The use of the word “NOTICE” identifies special instructions that are important but not related to hazards.

DISCONTINUED PRODUCT



# FireLock® European Dry Valve Stations

SERIES 756

WITH SERIES 776 LOW-PRESSURE ACTUATOR

## INSTALLER SAFETY INSTRUCTIONS

### ⚠ WARNING

	<ul style="list-style-type: none"> <li>• An experienced, trained installer must install this product in accordance with all instructions. These instructions contain important information.</li> </ul>
	<ul style="list-style-type: none"> <li>• Depressurize and drain the piping system before attempting to install, remove, adjust, or maintain any Victaulic piping products.</li> </ul> <p>Failure to follow these instructions can cause product failure, resulting in serious personal injury and/or property damage.</p>

### GENERAL

1. **Read and understand all instructions and refer to the trim diagrams before proceeding with the installation, maintenance, and testing of this Victaulic Series 756 FireLock Dry Valve.**
2. **Inspect the shipment.** Make sure all components are included in the shipment and that all necessary tools are available for installation.
3. **Use only recommended accessories.** Accessories and equipment that are not approved for use with this dry valve may cause improper system operation.
4. **Wear safety glasses, hardhat, foot protection, and hearing protection.** Wear hearing protection if you are exposed to long periods of noisy job-site operations.
5. **Prevent back injury.** Larger and pre-trimmed valves are heavy and require more than one person or mechanical lifting equipment to position and install the assembly. Always practice proper lifting techniques.
6. **Avoid using electrically powered tools in dangerous environments.** When using electrically powered tools for installation, make sure the area is moisture-free. Keep the work area well lit, and allow enough space to accommodate proper installation of the valve, trim, and accessories.
7. **Watch for pinch points.** Do not place fingers under the valve body where they could be pinched by the weight of the valve. Use caution around spring-loaded components (i.e. clapper assembly).
8. **Keep work areas clean.** Cluttered areas, benches, and slippery floors can create hazardous working conditions.
9. **PROTECT THE SYSTEM FROM FREEZING CONDITIONS. THE VALVE AND SUPPLY PIPING MUST BE PROTECTED FROM FREEZING TEMPERATURES AND MECHANICAL DAMAGE.**
10. **IF THE INLET WATER SUPPLY IS INTERRUPTED FOR ANY REASON, AND SYSTEM SUPPLY PRESSURE TO THE VALVE DECREASES, MAKE SURE THE PISTON CHARGE LINE IS FULLY PRESSURIZED BEFORE PLACING THE SYSTEM BACK IN SERVICE.**

### MAINTENANCE AND TESTING

1. **Notify the authority having jurisdiction.** Always notify the authority having jurisdiction before performing any maintenance that eliminates the fire protection provided by the system.
2. **Follow national requirements and/or requirements of the local authority having jurisdiction for system testing and inspection schedules.** The building owner or their representative is responsible for inspecting the system in accordance with current national requirements or in accordance with the requirements of the local authority having jurisdiction (whichever is more stringent).
3. **Depressurize and drain the system completely before performing any maintenance.** Water under pressure can cause the cover plate to blow off during removal if the system is not depressurized and drained completely.
4. **Protect the valve from freezing temperatures, foreign matter, and corrosive atmospheres.** Any condition that might degrade the system or affect system performance must be avoided.

# FireLock® European Dry Valve Stations

SERIES 756  
WITH SERIES 776 LOW-PRESSURE ACTUATOR

## INTRODUCTION

The following instructions are a guide for proper installation of Victaulic Series 756 FireLock Dry Valves. These instructions involve pipe that is properly prepared and grooved in accordance with Victaulic specifications.

### NOTICE

- Drawings and/or pictures in this manual may be exaggerated for clarity.
- This product and this installation, maintenance, and testing manual contain trademarks, copyrights, and/or patented features that are the exclusive property of Victaulic.

## TRIM DIMENSIONS

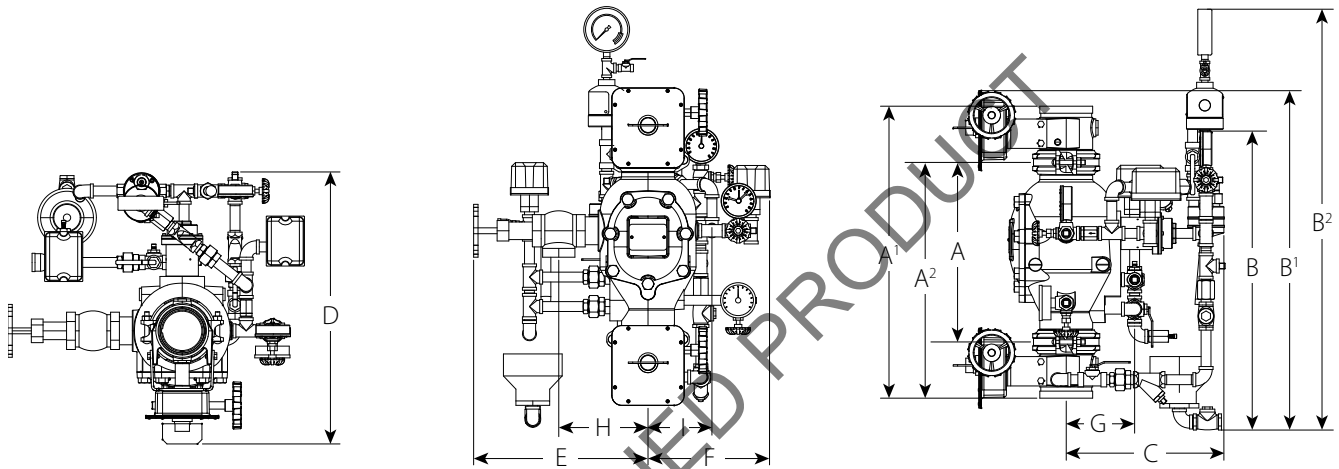

Size	Dimensions – centimeters													Approx. Weight Ea.
	A*	A1	A2	B	B¹	B2	C	D	E	F	G	H	I	kg
DN80	32.03	59.00	42.24	70.00	71.70	92.50	34.26	55.90	30.17	22.80	14.04	16.65	12.88	46.0
DN100	38.18	63.12	50.66	64.63	73.37	92.00	34.10	58.80	37.72	26.28	14.79	19.30	13.82	67.0
DN150	40.64	71.99	56.32	67.02	78.19	93.00	38.26	65.44	38.68	25.38	18.17	20.27	15.38	80.0
DN200	44.45	86.32	65.38	68.59	86.17	95.00	37.53	64.39	42.16	28.71	20.86	23.75	18.67	116.0

\* The "A" dimension is the measurement from the top of the valve body to the bottom of the valve body (takeout dimension).

NOTE: the upper butterfly valve is optional.

# FireLock® European Dry Valve Stations

SERIES 756  
WITH SERIES 776 LOW-PRESSURE ACTUATOR

## EXPLODED VIEW DRAWING – TRIM COMPONENTS

### Bill of Materials

- |  |   |
|--|---|
| 1 Series 756 FireLock European Dry System Valve            | 15 Drip Cup (Supplied by Installer)                                     |
| 2 FireLock Butterfly Valve with Tap                        | 16 Alarm Line Ball Valve  |
| 3 FireLock Rigid Coupling                                  | (Lockable - Normally Open)  |
| 4 System Main Drain Valve                                  | 17 Alarm Test Ball Valve (Normally Closed)                              |
| 5 Water Supply Pressure Gauge (0-25 Bar)                   | 18 Restricted Orifice/Alarm Line Drain                                  |
| 6 Gauge Valve  | 19 EPS-10 Alarm Pressure Switch   |
| 7 System Pressure Gauge with Mark Pointers (0-16 Bar)      | 20 Reducer (1.3 x 1.9 cm)   |
| 8 Piston-Charge-Line Ball Valve (Lockable - Normally Open) | 21 Series 760 Water Motor Alarm with 19-mm 100-Mesh Strainer (Optional) |
| 9 Piston-Charge-Line Strainer (100 Mesh)                   | 22 Union  |
| 10 Piston-Charge-Line Check Valve                          | 23 Series 748 Ball Check Valve  |
| 11 Piston-Charge-Line Pressure Gauge (0-25 Bar)            | 24 Restrictor   |
| 12 Series 749 Auto Drain                                   | 25 Piston-Charge-Line Restrictor (0.2 cm)                               |
| 13 Series 776 Low-Pressure Actuator                        | 26 EPS-40 Low-Air Pressure Switch                                       |
| 14 Drain Check Valve                                       | 27 Series 757 Air Maintenance Trim Assembly (AMTA) (Optional)           |
|  | 28 Series 746-LPA Dry Accelerator (Optional)                            |

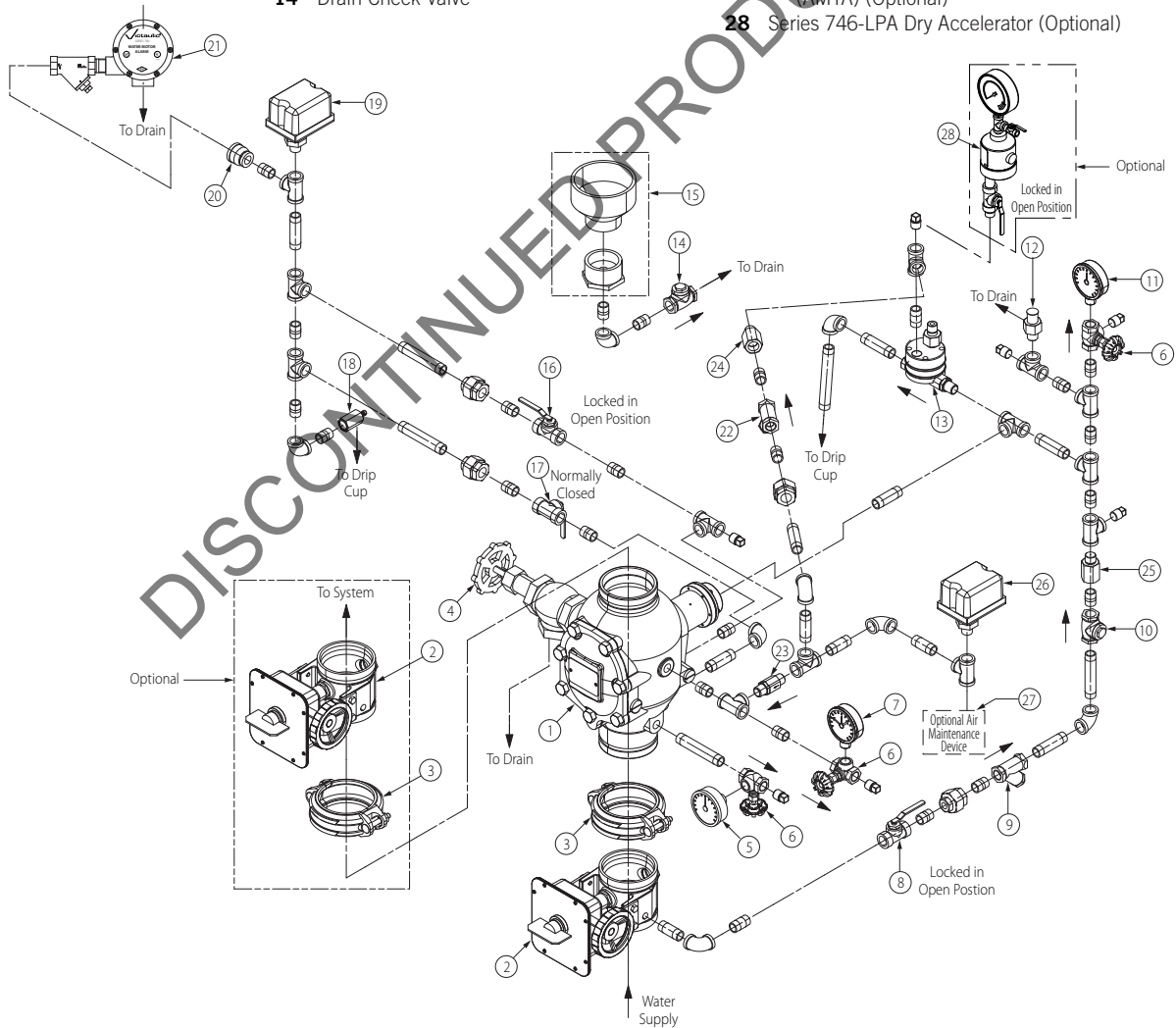

# FireLock® European Dry Valve Stations

SERIES 756  
WITH SERIES 776 LOW-PRESSURE ACTUATOR

## EXPLODED VIEW DRAWING – INTERNAL VALVE COMPONENTS

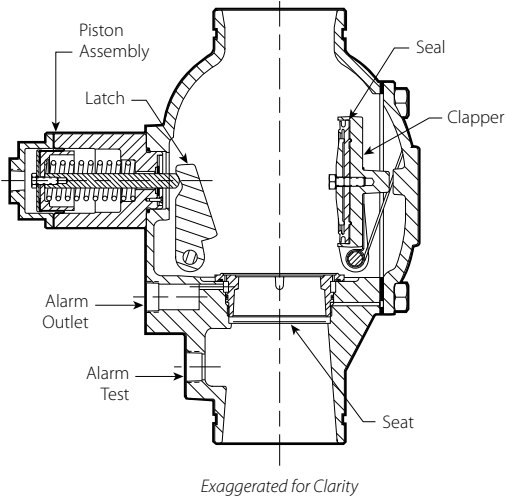

### Bill of Materials

- |    |                     |    |                                 |
|----|---------------------|----|---------------------------------|
| 1  | Valve Body          | 11 | Clapper Shaft Retaining Bushing |
| 2  | Clapper             | 12 | Latch Shaft                     |
| 3  | Clapper Seal        | 13 | Latch Shaft Retaining Bushing   |
| 4  | Seal Ring           | 14 | Piston O-ring                   |
| 5  | Seal Washer         | 15 | Piston                          |
| 6  | Seal-Retaining Ring | 16 | Cover Plate Gasket              |
| 7  | Bolt Seal           | 17 | Cover Plate                     |
| 8  | Seal Assembly Bolt  | 18 | Cover Plate Bolt                |
| 9  | Clapper Spring      | 19 | Latch                           |
| 10 | Clapper Shaft       | 20 | Latch Spring                    |

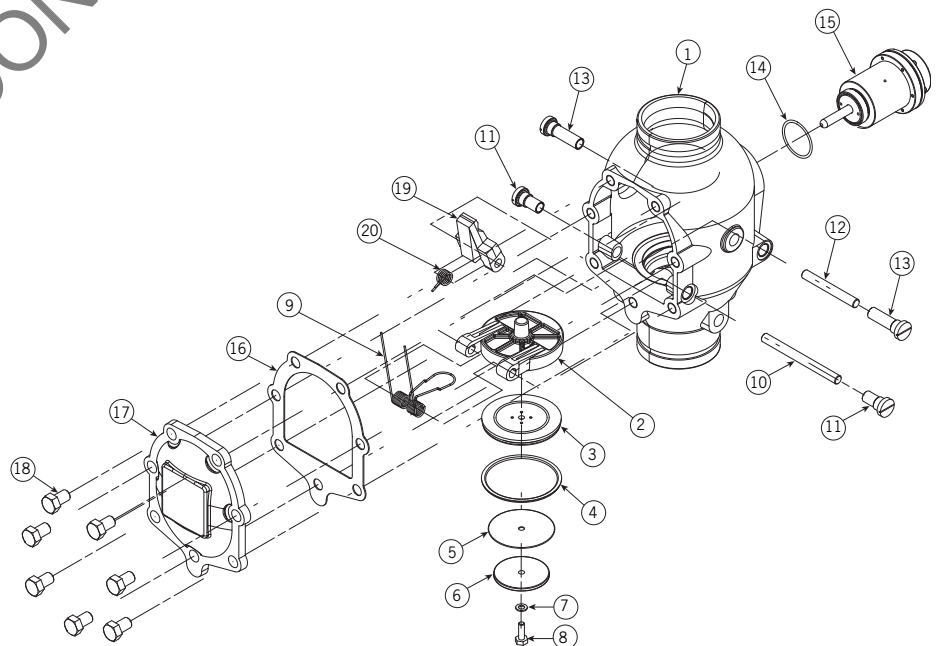

# FireLock® European Dry Valve Stations

**SERIES 756  
WITH SERIES 776 LOW-PRESSURE ACTUATOR**

## SECTION VIEW DRAWING AND DESCRIPTION – SERIES 776 LOW-PRESSURE ACTUATOR

The Series 776 Low-Pressure Actuator is located in the trim of Series 756 FireLock Dry Valves and acts as the trigger for these systems.

Diaphragms separate the low-pressure actuator into three chambers. The upper air chamber controls activation, while the middle and lower chambers act as the water valve.

During setup, system air is applied to the upper chamber of the low-pressure actuator. When the Auto Vent Sleeve of the low-pressure actuator is pulled up, the upper chamber manually sets. Air pressure in the upper chamber holds the Auto Vent closed, while it exerts force on the water seal of the middle chamber.

When the piston charge line is opened, water enters the lower chamber of the low-pressure actuator. Water that enters the low-pressure actuator flows to the middle chamber through the inlet eyelet, which is pressurized by system air pressure in the upper chamber.

Since the area of the lower diaphragm (exposed to water pressure in the middle chamber) is greater than the area of the lower chamber, the lower chamber seals off. Water does not flow to the outlet of the low-pressure actuator, and the supply water pressure creates the water seal.

When system air pressure decays to 0.4 Bar, the force exerted by the compression spring in the Auto Vent is greater than the force exerted by air in the upper chamber. The Auto Vent opens, and all air pressure in the upper chamber evacuates.

The upper diaphragm releases water pressure in the middle chamber of the low-pressure actuator, which allows the lower diaphragm to lift and water to flow from the inlet to the outlet. This flow of water releases pressure from the piston charge line of the Series 756 FireLock Dry Valve, thus allowing the piston to retract. The clapper opens, and water flows into the sprinkler system.

**Bill of Materials**

- |          |                             |           |                               |
|----------|-----------------------------|-----------|-------------------------------|
| <b>1</b> | Auto Vent Sleeve            | <b>9</b>  | Lower Diaphragm Assembly      |
| <b>2</b> | Auto Vent Screw             | <b>10</b> | Strainer Screen (Replaceable) |
| <b>3</b> | Auto Vent Assembly          | <b>11</b> | Strainer O-Ring Seal          |
| <b>4</b> | Upper Chamber               | <b>12</b> | Strainer Assembly             |
| <b>5</b> | Upper Diaphragm Wave Spring | <b>13</b> | Inlet Eyelet                  |
| <b>6</b> | Lower Diaphragm Wave Spring | <b>14</b> | Middle Chamber                |
| <b>7</b> | Outlet Eyelet               | <b>15</b> | Upper Diaphragm Assembly      |
| <b>8</b> | Lower Chamber               |           |                               |

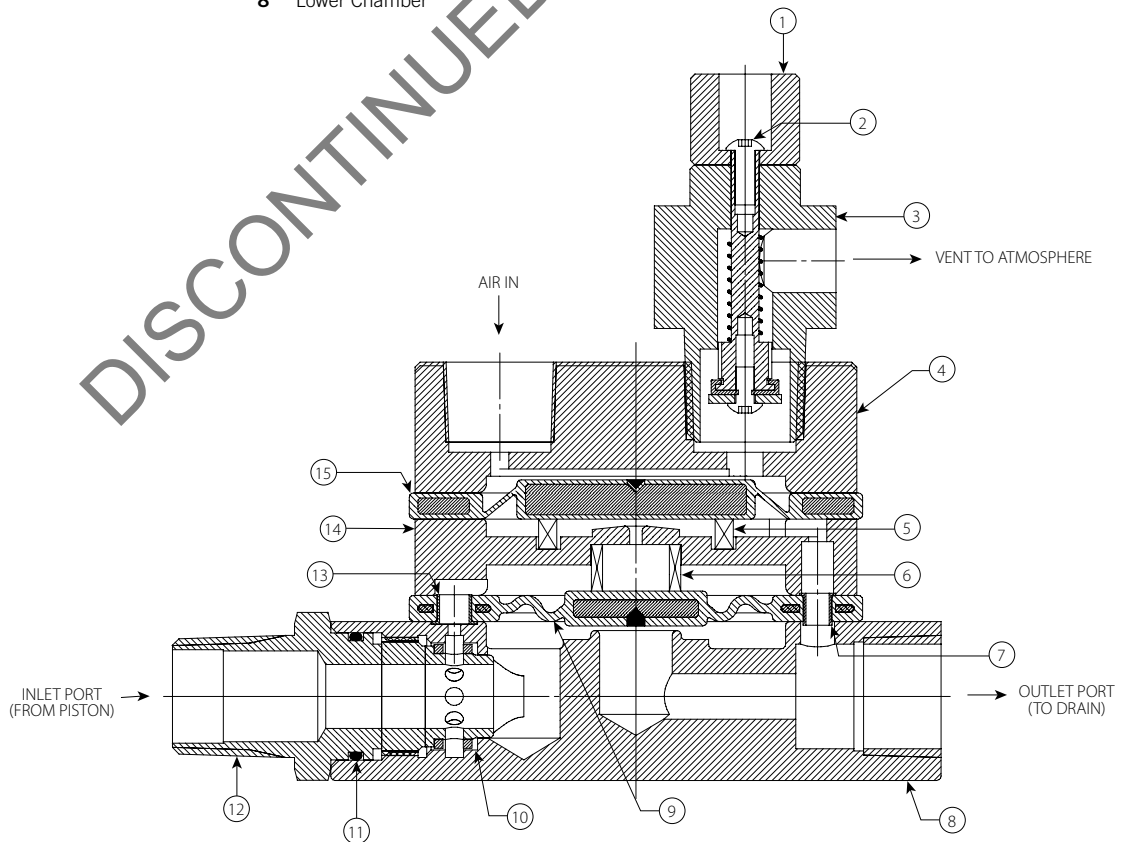

*Exaggerated for Clarity*



# FireLock® European Dry Valve Stations

**SERIES 756  
WITH SERIES 776 LOW-PRESSURE ACTUATOR**

## SECTION VIEW DRAWING AND DESCRIPTION – SERIES 746-LPA DRY ACCELERATOR

The Series 746-LPA Dry Accelerator exhausts air from the actuator to speed valve operation.

A diaphragm separates the Series 746-LPA Dry Accelerator into two chambers. The closing chamber contains a compression spring, which maintains the chamber in the closed position. The closed position is maintained as long as the pressure differential between the opening and closing chambers is less than 0.2 Bar.

When the system introduces air pressure into the dry accelerator, air enters the closing chamber and passes through a built-in check valve to the opening chamber. The built-in check valve, which allows flow into the opening chamber, prevents pressure from escaping the opening chamber. Therefore, air can escape only through the restrictor.

When a rapid loss of system air pressure occurs, such as an open sprinkler, air escapes from the closing chamber faster than it escapes from the opening chamber. As the sprinkler system's pressure continues to decay, a differential pressure develops across the diaphragm. When this differential pressure reaches 0.2 – 0.3 Bar, the opening chamber's pressure overcomes the compression spring's closing force, causing the closing chamber to open to the atmosphere. The closing chamber opens immediately and releases pressure from the actuator, resulting in valve operation.

**Manufacturer's Recommended Pressures:**

- Minimum Water Supply Pressure = 2.0 Bar
- Minimum Air Supply Pressure = 1.4 Bar
- Maximum Air Supply Pressure = 1.6 Bar

**Bill of Materials**

- |   |  |
|---|--|
| <ul style="list-style-type: none"> <li>1 Opening/Air Chamber</li> <li>2 Piston</li> <li>3 Restrictor</li> <li>4 Diaphragm</li> <li>5 Closing Chamber</li> <li>6 Actuator Shaft</li> <li>7 Compression Spring</li> </ul> | <ul style="list-style-type: none"> <li>8 Seal Support</li> <li>9 Button-Head Cap Screw</li> <li>10 Closing Chamber Seal</li> <li>11 Washer</li> <li>12 Adjustable Seat</li> <li>13 Built-In Check Valve</li> </ul> |
|---|--|

DISCONTINUED PRODUCT

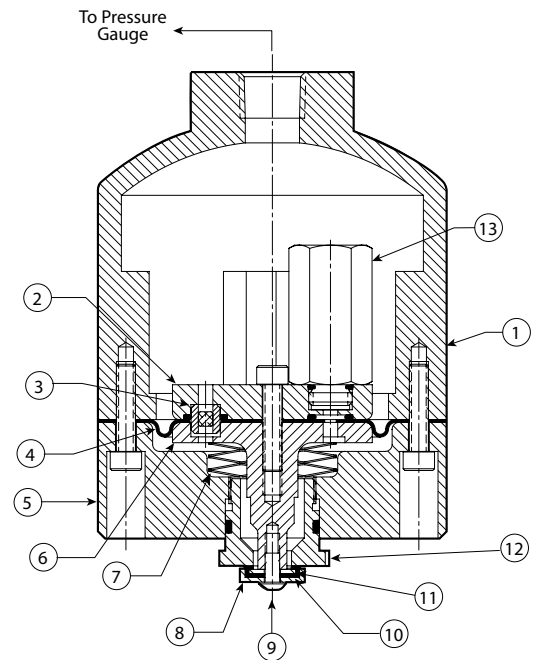

*Exaggerated for Clarity*

# FireLock® European Dry Valve Stations

**SERIES 756  
WITH SERIES 776 LOW-PRESSURE ACTUATOR**

## AIR SUPPLY REQUIREMENTS

The required air pressure for Series 756 FireLock Dry Valves is 0.9 Bar minimum, regardless of the system supply pressure. Air pressure must be kept below 1.2 Bar.

Systems that require a Series 746-LPA Dry Accelerator should have air pressure between 1.4 Bar and 1.6 Bar. **NOTE:** Air pressure should not exceed 1.6 Bar. Refer to the requirements below.

Manufacturer’s Recommended Pressures – Series 746-LPA Dry Accelerator:

- Minimum Water Supply Pressure = 2.0 Bar
- Minimum Air Supply Pressure = 1.4 Bar
- Minimum Air Supply Pressure = 1.6 Bar

If multiple Series 756 FireLock Dry Valves are installed with a common air supply, isolate the systems with a spring-loaded, soft-seated ball check valve to ensure air integrity for each system. Good practice is to include a ball valve for isolation and service of each individual system.

Set the air pressure to the required system air pressure. Air pressure differing from the required system air pressure could reduce system operation response time.

The engineer/system designer is responsible for sizing the compressor so that the entire system is charged to the required air pressure within 30 minutes. DO NOT oversize the compressor to provide more airflow. An oversized compressor will slow down or possibly prevent valve operation.

If the compressor fills the system too fast, it may be necessary to restrict the air supply. Restricting the air supply will ensure that air being exhausted from an open sprinkler or manual release valve is not replaced by the air supply system as fast as it is being exhausted.

## COMPRESSOR SIZING

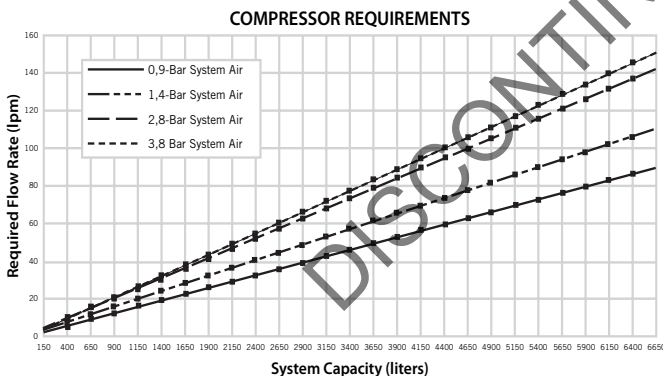

## BASE OR RISER-MOUNTED AIR COMPRESSORS

For base or riser-mounted air compressors, the recommended air pressure of 0.9 Bar is the “on” or “low” pressure setting for the compressor. The “off” or “high” pressure setting should be 1.2 Bar.

When a base or riser-mounted air compressor supplies air to a Series 756 FireLock Dry Valve, it is not necessary to install the Victaulic Series 757 Regulated Air Maintenance Trim Assembly (AMTA). In this case, the airline of the compressor connects to the trim at the fitting where the Series 757 Regulated AMTA is normally installed (refer to the applicable trim drawing). If the compressor is not equipped with a pressure switch, the Series 757P Air Maintenance Trim Assembly with Pressure Switch should be installed.

## SHOP AIR OR TANK-MOUNTED AIR COMPRESSORS

In the event a compressor becomes inoperative, a properly sized tank-mounted air compressor provides the greatest protection for systems.

When shop air or a tank-mounted air compressor is used, the Series 757 Regulated AMTA must be installed. The Series 757 Regulated AMTA provides proper air regulation from the air reservoir to the sprinkler system.

For tank-mounted air compressors, the recommended air pressure of 0.9 Bar should be used as the set point for the air regulator. The “on” pressure of the compressor should be at least 0.3 Bar above the set point of the air regulator.

## VICTAULIC SERIES 757 REGULATED AIR MAINTENANCE TRIM ASSEMBLY (AMTA)

**NOTICE**

- Victaulic recommends a maximum of two Series 756 FireLock Dry Valves per Series 757 Regulated AMTA.

### Bill of Materials

- 1 3.2-mm Restrictor
- 2 Slow Fill Ball Valve (Normally Open)
- 3 Air Regulator
- 4 Strainer (100 Mesh)
- 5 Spring-Loaded, Soft-Seated Ball Check Valve
- 6 Fast Fill Ball Valve (Normally Closed)

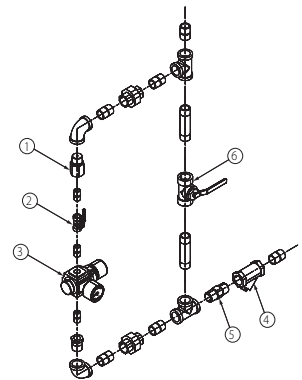

## VICTAULIC SERIES 757P AIR MAINTENANCE TRIM ASSEMBLY (AMTA) WITH PRESSURE SWITCH

**NOTICE**

- Victaulic recommends a maximum of two Series 756 FireLock Dry Valves per Series 757P AMTA with Pressure Switch.

### Bill of Materials

- 1 3.2-mm Restrictor
- 2 Pressure Switch
- 3 Slow Fill Ball Valve (Normally Open)
- 4 Fast Fill Ball Valve (Normally Closed)
- 5 Strainer (100 Mesh)
- 6 Spring-Loaded, Soft-Seated Ball Check Valve

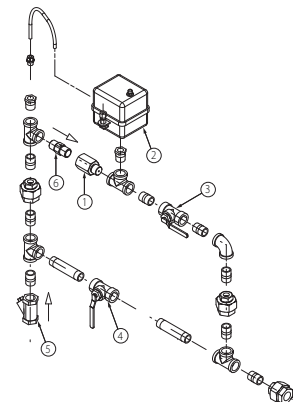

## FireLock® European Dry Valve Stations

### SERIES 756 WITH SERIES 776 LOW-PRESSURE ACTUATOR

#### COMPRESSOR REQUIREMENTS AND SETTINGS FOR SERIES 756 FIRELOCK DRY VALVES INSTALLED WITH SERIES 746-LPA DRY ACCELERATORS

Set the air regulator of the Series 757 Regulated AMTA to 0.9 Bar.

#### THE SERIES 757P AIR MAINTENANCE TRIM ASSEMBLY WITH PRESSURE SWITCH MUST NOT BE USED ON A SERIES 756 FIRELOCK DRY VALVE INSTALLED WITH A SERIES 746-LPA DRY ACCELERATOR.

When a Series 756 FireLock Dry Valve is installed with a Series 746-LPA Dry Accelerator, the Series 757 Regulated AMTA must be used. **NOTE:** The use of an air regulator with a base or riser-mounted compressor could cause short cycling, resulting in premature wear of the compressor.

In the event a compressor becomes inoperative, a properly sized tank-mounted air compressor provides the greatest protection for systems installed with a Series 746-LPA Dry Accelerator. In this situation, air can be supplied continuously to the sprinkler system for an extended time period. **NOTE:** The Series 757 Regulated AMTA should be used with a tank-mounted air compressor that supplies air to a Series 756 FireLock Dry Valve installed with a Series 746-LPA Dry Accelerator.

The air regulator of the Series 757 Regulated AMTA is a relief-type design. Any pressure in the system that is above the set point of the air regulator will be released. Therefore, charging the air regulator above the set point could cause premature operation of a valve installed with a Series 746-LPA Dry Accelerator.

#### SETTINGS FOR AIR SUPERVISORY PRESSURE SWITCHES AND ALARM PRESSURE SWITCHES

1. Air supervisory pressure switches are required for dry systems and must be set according to the following notes.
  - 1a. Wire the air supervisory pressure switches to activate a low-pressure alarm signal. **NOTE:** In addition, the local authority having jurisdiction may require a high-pressure alarm. Contact the local authority having jurisdiction for this requirement.
  - 1b. Set the air supervisory pressure switches to activate at 0.1 – 0.3 Bar below the minimum air pressure required (but not lower than 0.7 Bar).
  - 1c. Wire the alarm pressure switch to activate a water flow alarm.
  - 1d. Set the alarm pressure switch to activate on a pressure rise of 0.3 – 0.6 Bar.

#### REMOTE SYSTEM TEST VALVE REQUIREMENTS

The remote system test valve (inspector's test connection) should contain an approved valve (normally closed), which can be opened to simulate the operation of a sprinkler.

The remote system test valve (inspector's test connection) should be located at the most hydraulically demanding location in the release system. **NOTE:** Multiple restrictions on the remote system test valve (inspector's test connection) may slow the air decay rate and cause the system to respond slower than required.

The remote system test valve (inspector's test connection) should terminate with an orifice equal to the smallest orifice in the releasing system.

The remote system test valve (inspector's test connection) is used to ensure that water reaches the most remote part of the system within 60 seconds.

#### IMPORTANT INSTALLATION INFORMATION

1. For proper operation and approval, the Series 756 FireLock Dry Valve must be installed in accordance with the specific trim diagrams included with the shipment. **NOTE:** Victaulic provides specific trim diagrams for installations involving a Series 746-LPA Dry Accelerator.
2. Before installing the Series 756 FireLock Dry Valve, flush the water supply piping thoroughly to remove all foreign material.
3. Series 756 FireLock Dry Valves MUST NOT be located in an area where the valve can be exposed to freezing temperatures. In addition, the Series 756 FireLock Dry Valve MUST NOT be located in an area where physical damage may occur.
4. It is the system designer's responsibility to confirm material compatibility of the Series 756 FireLock Dry Valve, trim, and associated accessories when a corrosive environment or contaminated water is present.
5. **SERIES 756 FIRELOCK DRY VALVES MUST BE INSTALLED ONLY IN THE VERTICAL POSITION WITH THE ARROW ON THE BODY POINTING UPWARD.**
6. Air or nitrogen supply to the dry piping system must be clean, dry, and oil-free.
7. Air supplies must be regulated, restricted, and continuous. **NOTE:** Victaulic recommends the use of the AMTA on any system with an automatic air supply.
8. When the Series 756 FireLock Dry Valve is used with a water motor alarm, Victaulic recommends the use of an uninterrupted, low-pressure alarm that is installed on the piston charge line downstream of the check valve. Another option is to install a Series 75B Supplemental Alarm Device.
9. Piping must be pitched so that systems can drain properly. For areas that are subject to high levels of condensation, or where piping is not properly pitched, an optional Series 75D Water Column Device kit is available to assist in automatically draining water out of the riser.

# FireLock® European Dry Valve Stations

SERIES 756  
WITH SERIES 776 LOW-PRESSURE ACTUATOR

## VALVE/TRIM INSTALLATION

1. Make sure the trim drawing matches the system's requirements.

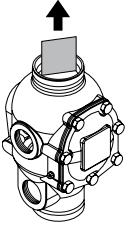
<b>⚠ CAUTION</b>	
	<ul style="list-style-type: none"> <li>• Make sure the foam spacer is removed from inside the valve body before attempting to install the valve.</li> </ul> <p>Failure to follow this instruction could cause improper valve operation, resulting in personal injury and/or property damage.</p>

2. Remove all plastic caps and foam spacers from the valve.
3. Apply a small amount of pipe joint compound or Teflon\* tape to the external threads of all threaded pipe connections. DO NOT get any tape, compound, or other foreign material into the valve body, pipe nipples, or valve openings.

<b>⚠ CAUTION</b>	
<ul style="list-style-type: none"> <li>• Make sure no foreign material gets into the valve body, pipe nipples, or valve openings.</li> <li>• If using any material other than Teflon tape, use extra caution so that no material gets into the trim.</li> </ul> <p>Failure to follow these instructions could cause improper valve operation, resulting in personal injury and/or property damage.</p>	

4. Install the valve, trim, and accessories per the trim drawing.

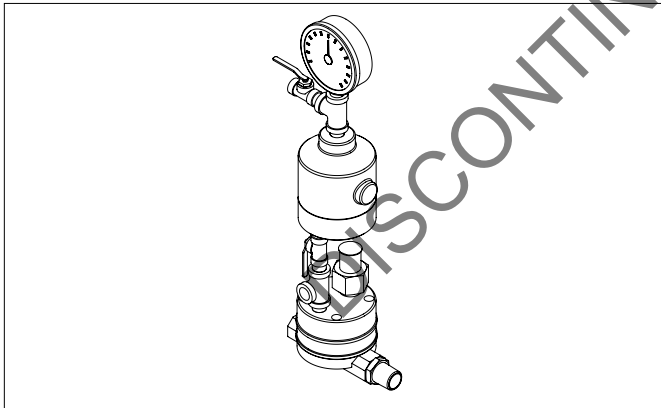

5. **FOR VALVES INSTALLED WITH A SERIES 746-LPA DRY ACCELERATOR:** Make sure the Series 746-LPA Dry Accelerator is installed on the Series 776 Low-Pressure Actuator, as shown in the drawing above. The end with the vent seal "button" must be installed facing toward the Series 776 Low-Pressure Actuator.
6. Supply pressure to the piston charge line by providing an uninterrupted source of water from upstream of the main control valve.

\* TEFLON IS A REGISTERED TRADEMARK OF THE DUPONT COMPANY

## HYDROSTATIC TESTING

The Victaulic Series 756 European Dry Valve is manufactured and listed for a maximum working pressure of 16 Bar and is factory tested to 41 Bar. The station can be hydrostatically tested to 14 Bar and/or 3.5 Bar above the normal water supply pressure (2-hour limited time period) for acceptance by the authority having jurisdiction.

# FireLock® European Dry Valve Stations

SERIES 756  
WITH SERIES 776 LOW-PRESSURE ACTUATOR

## PLACING THE SYSTEM IN SERVICE

### CAUTION

- Make sure the Series 756 FireLock Dry Valve is properly heated and protected from freezing temperatures and physical damage.

Failure to follow this instruction could cause improper valve operation, resulting in personal injury and/or property damage.

### NOTICE

- The callouts in the following photos correspond with the "Exploded View Drawing – Trim Components" information on page 4.

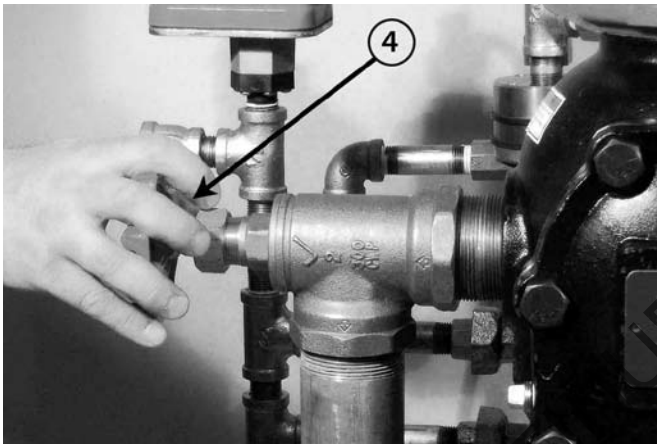

1. Open the system main drain valve (4). Confirm that the system is drained.



2. Close the system main drain valve (4).
3. Confirm that all system drains are shut and that the system is free of leaks.

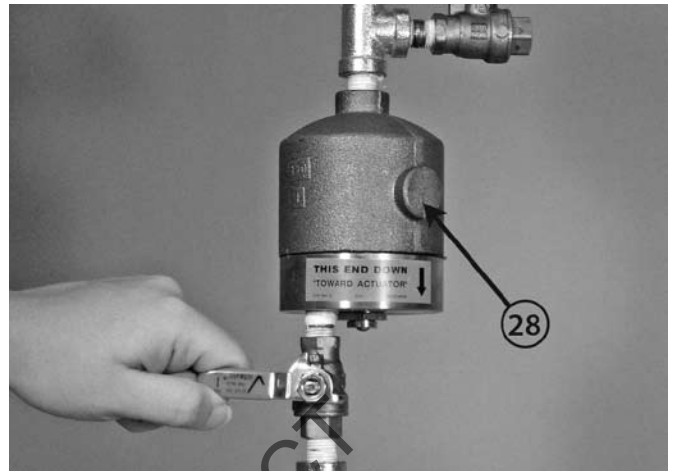

4. If a Series 746-LPA Dry Accelerator (28) is installed, confirm that the isolation ball valve is closed.

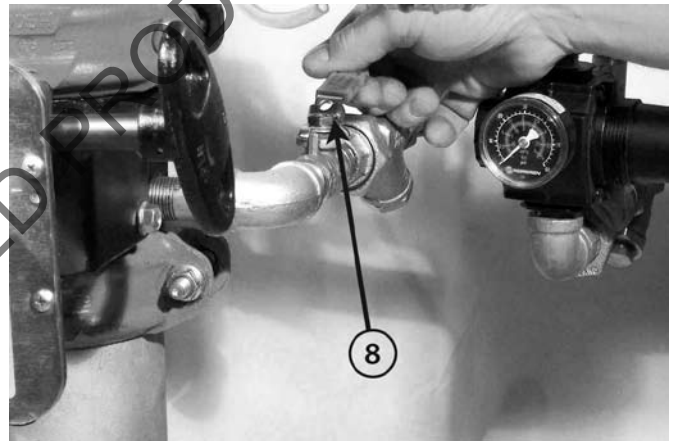

5. Open the piston-charge-line ball valve (8).

# FireLock® European Dry Valve Stations

SERIES 756  
WITH SERIES 776 LOW-PRESSURE ACTUATOR

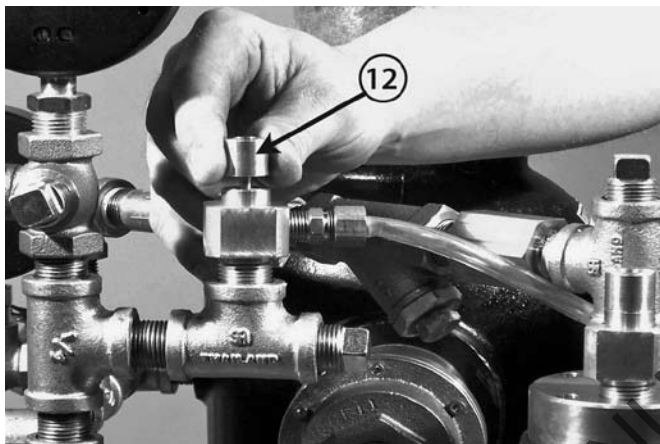
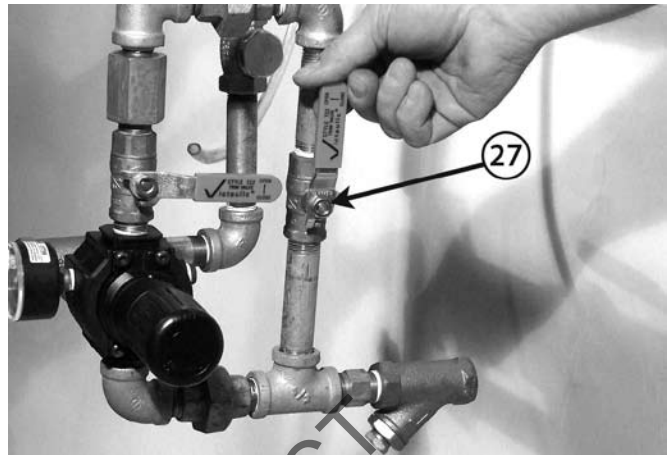
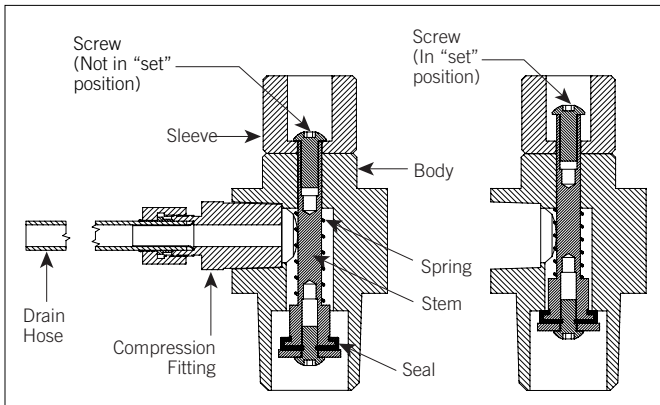

6. Confirm that water is flowing steadily from the Auto Drain (12). Pull up on the Auto Drain Sleeve, and confirm that water is flowing through the Series 776 Low-Pressure Actuator (13).

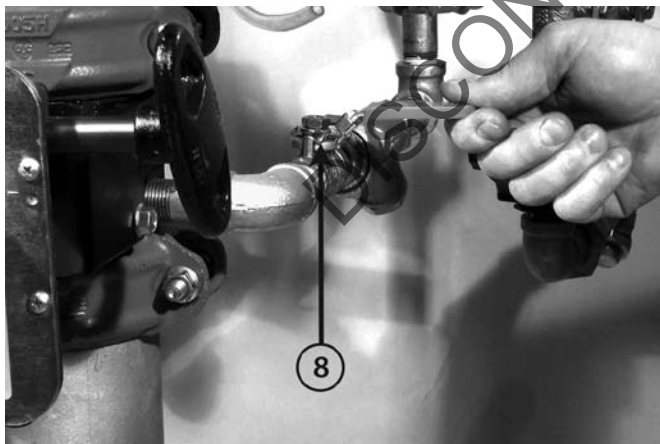

7. Close the piston-charge-line ball valve (8).

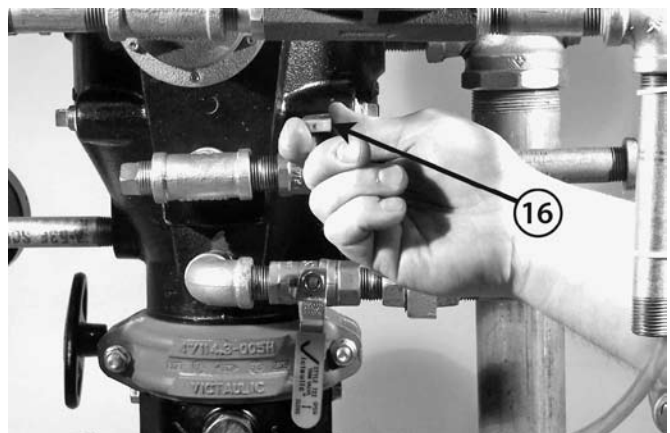
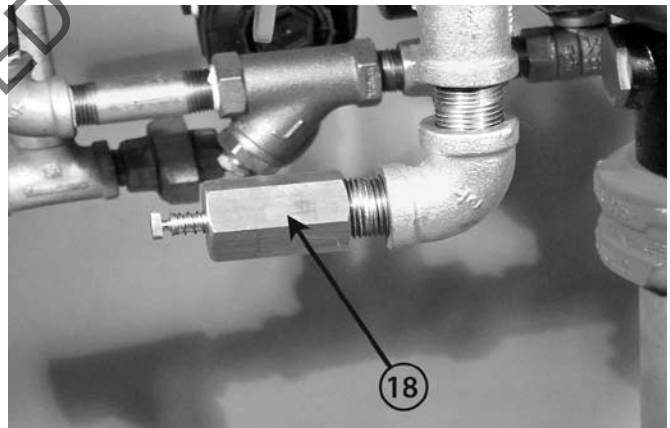

10. If air is leaking out of the restricted orifice/alarm line drain (18), close the alarm line ball valve (16).

# FireLock® European Dry Valve Stations

SERIES 756  
WITH SERIES 776 LOW-PRESSURE ACTUATOR

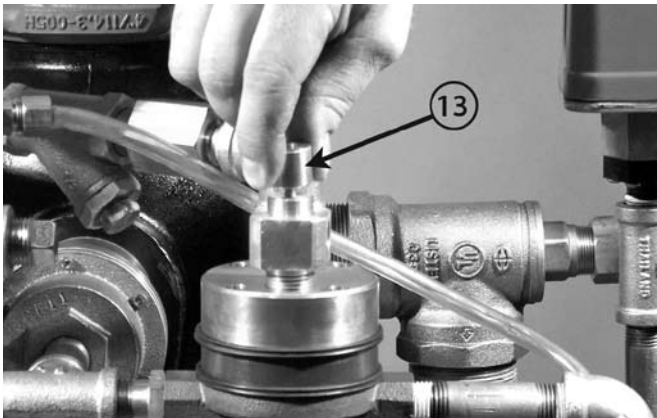

11. When the system reaches approximately 0.7 Bar, pull up on the Auto Vent Sleeve of the Series 776 Low-Pressure Actuator (13).  
**NOTE:** The Auto Vent Screw should seal and remain in the set ("UP") position.

11a. Confirm that no water is being exhausted from the Auto Vent of the Series 776 Low-Pressure Actuator (13). If water is being exhausted from the Auto Vent of the Series 776 Low-Pressure Actuator, continue to run air through the system. If a Series 746-LPA Dry Accelerator (28) is installed, make sure the accelerator is not flooded.

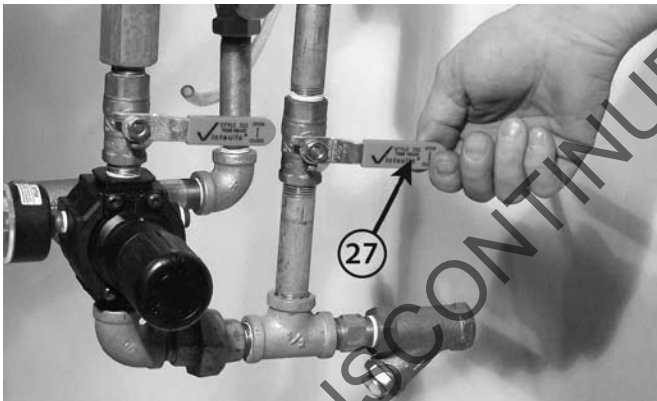

12. When system air pressure is established, close the fast-fill ball valve on the AMTA (27).

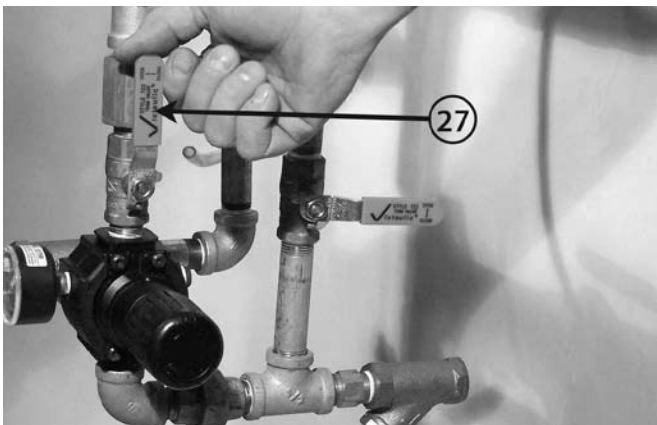

13. Open the slow-fill ball valve on the AMTA (27).

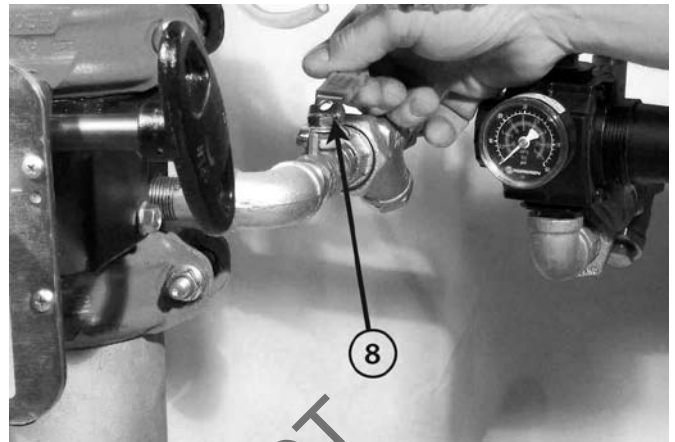

14. Open the piston-charge-line ball valve (8).

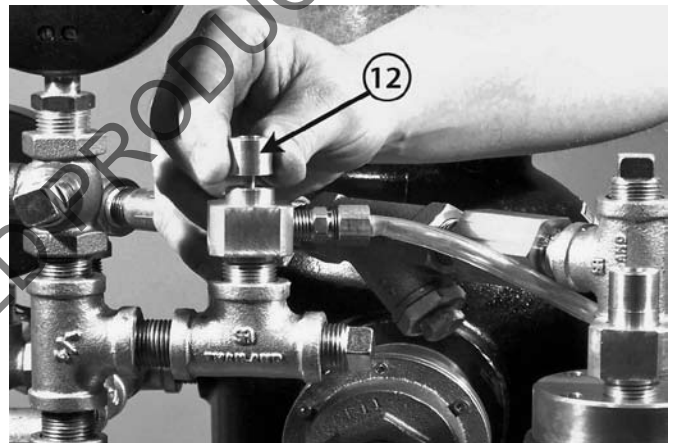

15. Pull up on the Auto Drain Sleeve (12) until the screw is in the set ("UP") position. Verify that there is pressure on the gauge to the piston charge line (11).



16. If a Series 746-LPA Dry Accelerator (28) is installed, open the 1/4-turn vent ball valve.

# FireLock® European Dry Valve Stations

SERIES 756  
WITH SERIES 776 LOW-PRESSURE ACTUATOR

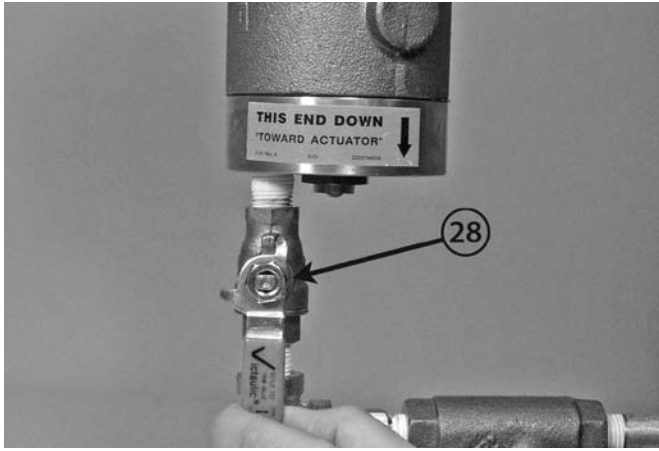

17. If a Series 746-LPA Dry Accelerator (28) is installed, open the isolation ball valve.



18. If a Series 746-LPA Dry Accelerator (28) is installed, close the 1/4-turn vent ball valve. This will set the accelerator.

19. Observe the system air pressure over a 24-hour period to confirm system integrity. If there is degradation in system air pressure, find and correct all leaks.

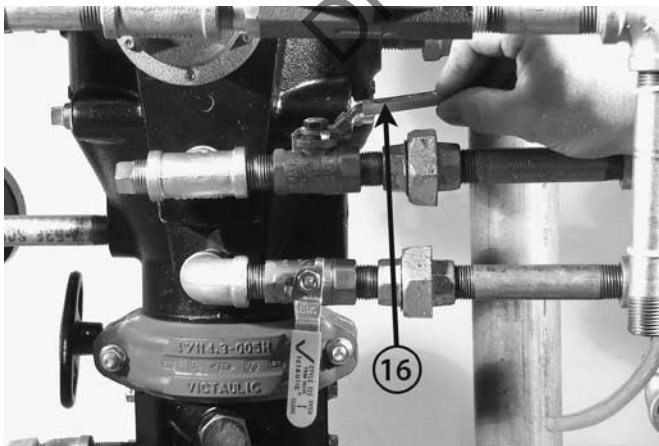

20. Open the alarm line ball valve (16).

**⚠ CAUTION**

- Take precautions when opening the water supply main control valve, since water will flow from all open system valves. Failure to follow this instruction could result in property damage.

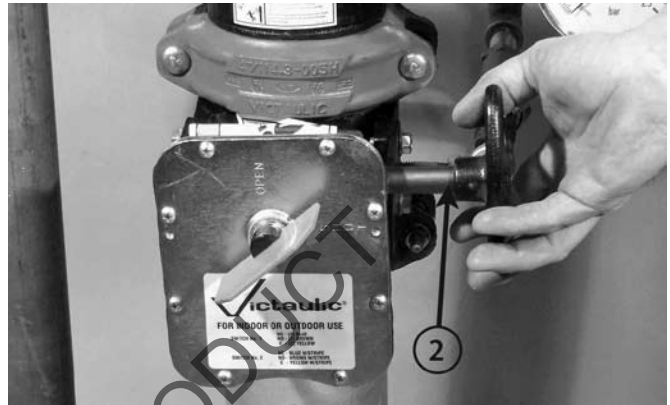

21. Open the water supply main control valve (2) slowly.

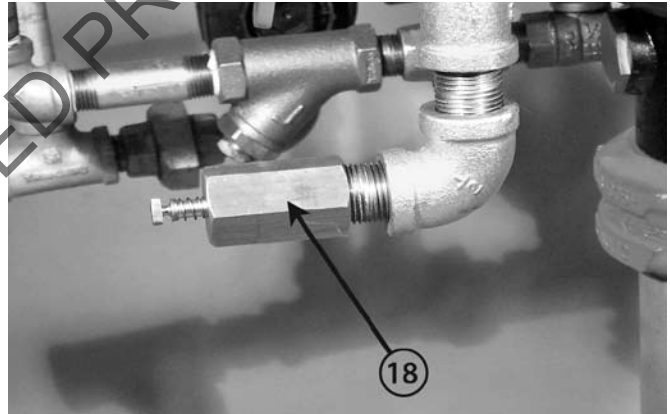

22. Confirm that there is no leakage from the intermediate valve chamber. The restricted orifice/alarm line drain (18) should not be leaking water or air.



23. If water is flowing from the restricted orifice/alarm line drain (18), close the water supply main control valve (2), and start over at step 1. Refer to the "Troubleshooting" section on page 26.



# FireLock® European Dry Valve Stations

**SERIES 756  
WITH SERIES 776 LOW-PRESSURE ACTUATOR**



24. Open the water supply main control valve (2) fully.
25. Record the system air pressure (7) and the water supply pressure (5).
26. Confirm that all valves are in their normal operating positions (refer to the table below).

Valve	Normal Operating Position
Piston-Charge-Line Ball Valve	Open (Lockable)
Alarm Line Ball Valve	Open (Lockable)
Alarm Test Ball Valve	Closed

27. Notify the authority having jurisdiction, remote station alarm monitors, and those in the affected area that the system is in service.

**ON A WEEKLY BASIS, WHEN THE VALVE IS RESET AFTER AN OPERATIONAL TEST (OR AFTER ANY SYSTEM OPERATION):** The low-body drain valve and any low-point drain valves should be partially opened and then closed to drain water that might be present in the riser. Continue this procedure until all water is released. **NOTE:** The optional Series 75D Water Column Kit can be installed to automate this step.

DISCONTINUED PRODUCT

# FireLock® European Dry Valve Stations

SERIES 756  
WITH SERIES 776 LOW-PRESSURE ACTUATOR

## EXTERNAL INSPECTION

### WARNING

- The building owner or their representative is responsible for maintaining the fire protection system in proper operating condition.
- To ensure proper system operation, valves must be inspected in accordance with current national standards or in accordance with the requirements of the local authority having jurisdiction (whichever is more stringent). Always refer to the instructions in this manual for additional inspection and testing requirements.
- The frequency of inspections must be increased in the presence of contaminated water supplies, corrosive/scaling water supplies, and corrosive atmospheres.
- Depressurize and drain the piping system before attempting to install, remove, adjust, or maintain any Victaulic products.

Failure to follow these instructions could cause system failure, resulting in death, serious personal injury, and property damage.

### NOTICE

- Any activities that require taking the valve out of service may eliminate the fire protection provided.
- Consideration of a fire patrol should be given for the affected areas.
- Before servicing or testing the system, notify the authority having jurisdiction.

## WEEKLY INSPECTION

1. Perform a visual inspection on the valve and trim on a weekly basis. **NOTE:** If the dry system is equipped with a low-pressure alarm, monthly inspections may be sufficient. Contact the local authority having jurisdiction for specific requirements.

## MONTHLY INSPECTION

1. Record the system air pressure (7) and water supply pressure (5). Confirm that the water supply pressure is within the range of normal pressures observed in the area. Significant loss of water supply pressure could indicate an adverse condition in the water supply. Confirm the proper water-to-air ratio is being maintained.

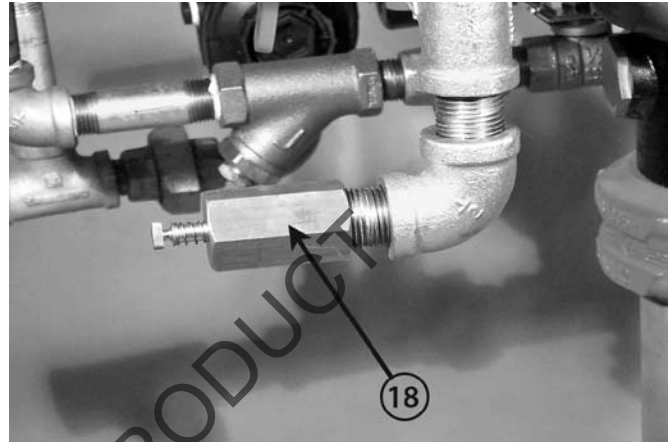

2. Confirm that there is no leakage from the intermediate valve chamber. The restricted orifice/alarm line drain (18) should not be leaking water or air.
3. Inspect the valve and trim for mechanical damage and corrosion. Replace any damaged or corroded parts.
4. Confirm that the dry valve and trim are located in an area that is not subject to freezing temperatures.
5. Confirm that all valves are in their normal operating positions (refer to the table below).

Valve	Normal Operating Position
Piston-Charge-Line Ball Valve	Open (Lockable)
Alarm Line Ball Valve	Open (Lockable)
Alarm Test Ball Valve	Closed

6. If a Series 746-LPA Dry Accelerator (28) is installed, record the pressure in the air chamber of the dry accelerator. The pressure in the air chamber should equal the system air pressure within the allowable tolerances of the gauges. If the air chamber's pressure is below the system air pressure, follow the "Troubleshooting" section on page 39.

# FireLock® European Dry Valve Stations

SERIES 756  
WITH SERIES 776 LOW-PRESSURE ACTUATOR

## REQUIRED SYSTEM TESTS

### **⚠ WARNING**

- The building owner or their representative is responsible for maintaining the fire protection system in proper operating condition.
- To ensure proper system operation, valves must be inspected in accordance with current national standards or in accordance with the requirements of the local authority having jurisdiction (whichever is more stringent). Always refer to the instructions in this manual for additional inspection and testing requirements.
- The frequency of inspections must be increased in the presence of contaminated water supplies, corrosive/scaling water supplies, and corrosive atmospheres.
- Depressurize and drain the piping system before attempting to install, remove, adjust, or maintain any Victaulic products.

Failure to follow these instructions could cause system failure, resulting in death, serious personal injury, and property damage.

### **NOTICE**

- Any activities that require taking the valve out of service may eliminate the fire protection provided.
- Consideration of a fire patrol should be given for the affected areas.
- Before servicing or testing the system, notify the authority having jurisdiction.

## WATER FLOW ALARM TEST

The authority having jurisdiction may have standards that require water flow alarm tests on a more frequent basis than national requirements. Verify these requirements by contacting the authority having jurisdiction in the affected area.

1. Notify the authority having jurisdiction, remote station alarm monitors, and those in the affected area that the water flow alarm test will be performed.

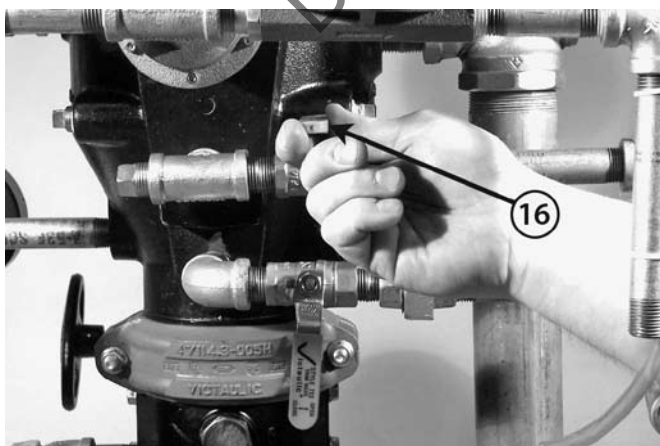

2. Close the alarm line ball valve (16).

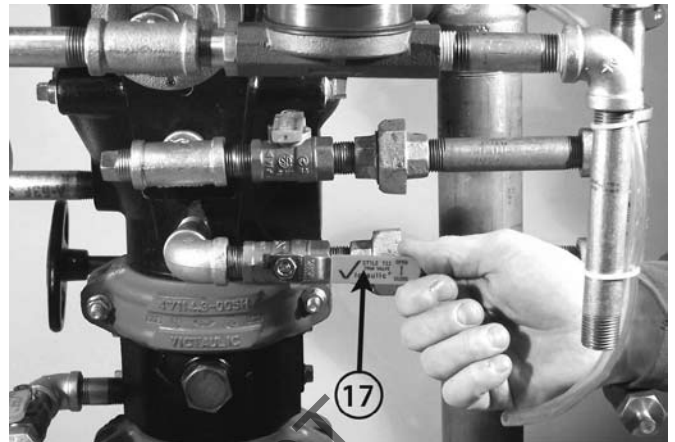

3. Open the alarm test ball valve (17). Confirm that mechanical and electrical alarms are activated and that remote monitoring stations, if provided, receive an alarm signal.

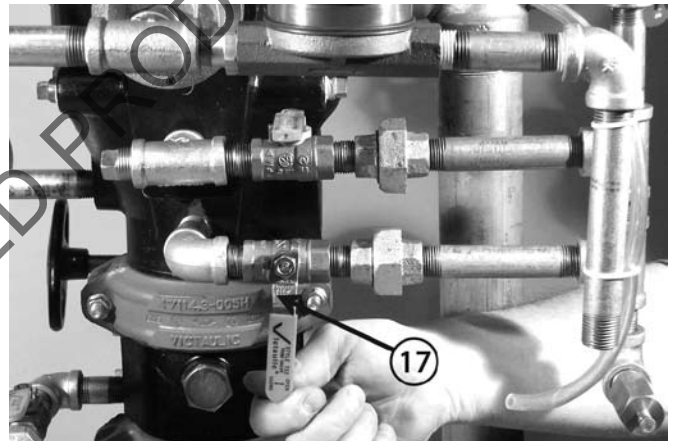

4. Close the alarm test ball valve (17) after verifying proper operation of all alarms.

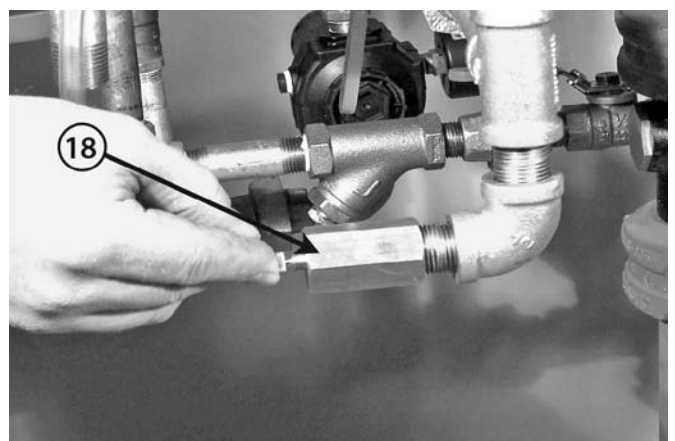

5. Push in the plunger of the restricted orifice/alarm line drain (18) to verify that there is no pressure in the alarm line.
6. Verify that all alarms stopped sounding, that the alarm line drained properly, and that remote station alarms reset properly.

# FireLock® European Dry Valve Stations

SERIES 756  
WITH SERIES 776 LOW-PRESSURE ACTUATOR

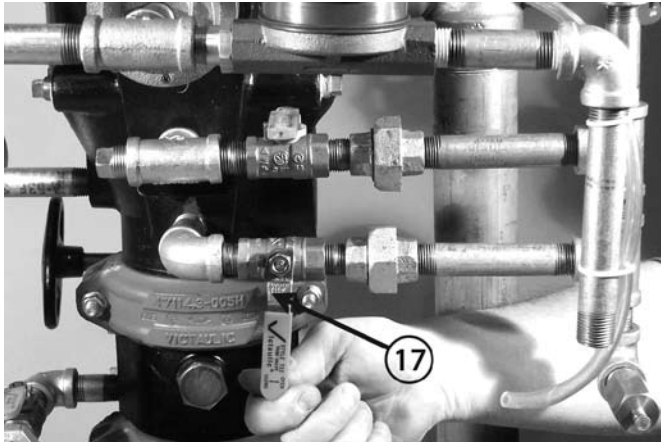

7. Confirm that the alarm test ball valve (17) is closed.

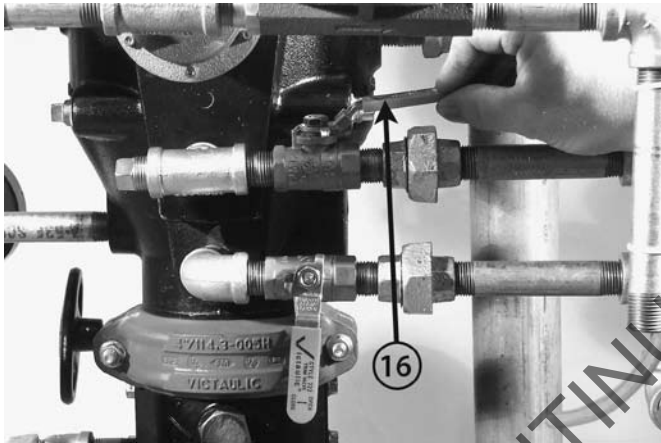

8. Open the alarm line ball valve (16).

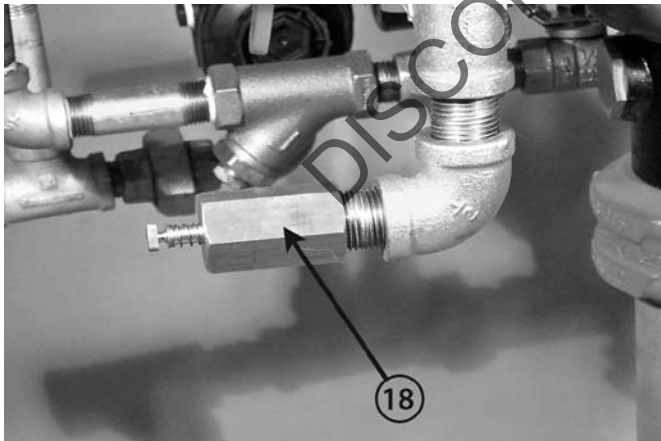

9. Confirm that there is no leakage from the intermediate valve chamber. The restricted orifice/alarm line drain (18) should not be leaking water or air.
10. Notify the authority having jurisdiction, remote station alarm monitors, and those in the affected area that the valve is back in service.
11. Provide test results to the authority having jurisdiction, if required.

## WATER LEVEL AND LOW AIR ALARM TESTS

The authority having jurisdiction may have standards that require water level and low air alarm tests on a more frequent basis than national requirements. Verify these requirements by contacting the authority having jurisdiction in the affected area.

### NOTICE

- If a Series 746-LPA Dry Accelerator is installed, make sure the authority having jurisdiction is notified that the water level and low air alarm tests are in progress. Failure to close the isolation ball valve of the Series 746-LPA Dry Accelerator may cause the valve to trip, resulting in a false alarm.

1. Notify the authority having jurisdiction, remote station alarm monitors, and those in the affected area that the water level and low air alarm tests will be performed.



2. If a Series 746-LPA Dry Accelerator (28) is installed, close the isolation ball valve.

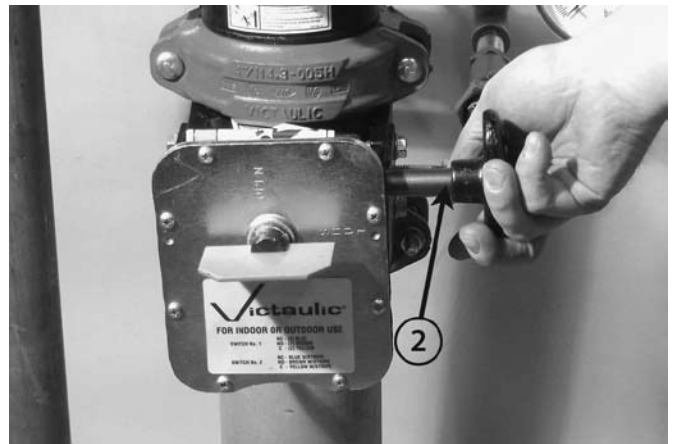

3. Close the water supply main control valve (2).

# FireLock® European Dry Valve Stations

SERIES 756  
WITH SERIES 776 LOW-PRESSURE ACTUATOR

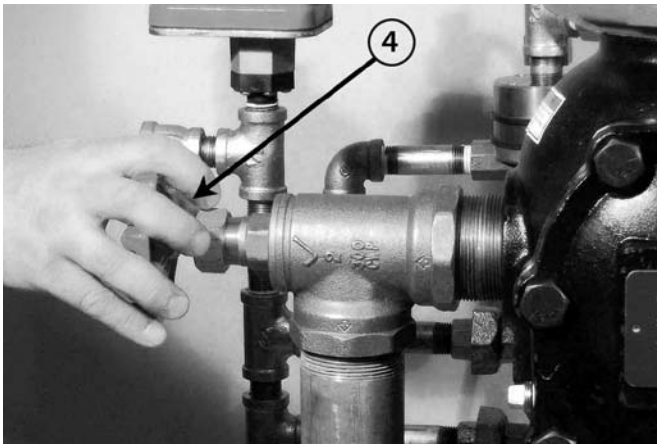

4. Partially open the system main drain valve (4) slowly. Confirm that water is not flowing from the drain. **NOTE:** If water is flowing from the drain, the system may not have drained properly. In this case, follow all steps under the "Placing the System in Service" section, starting on page 11.
5. Record the system air pressure at which the low air alarm activates.

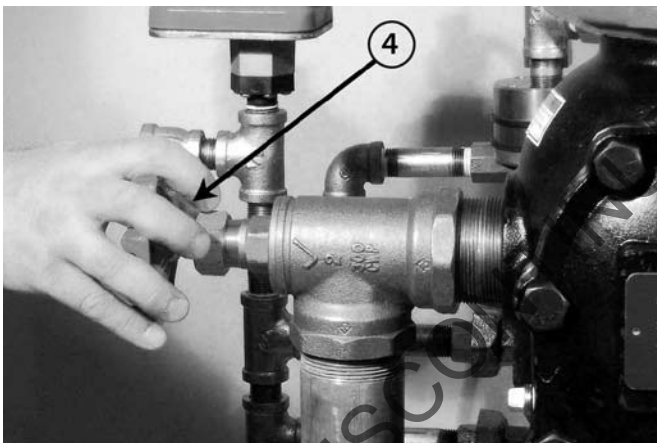

6. Close the system main drain valve (4).



7. Close the slow-fill ball valve on the AMTA (27).

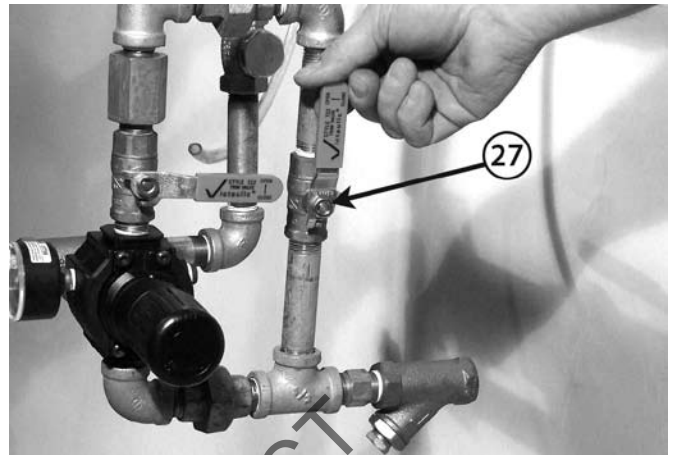

8. Open the fast-fill ball valve on the AMTA (27). Bring the pressure back up to the normal system pressure.

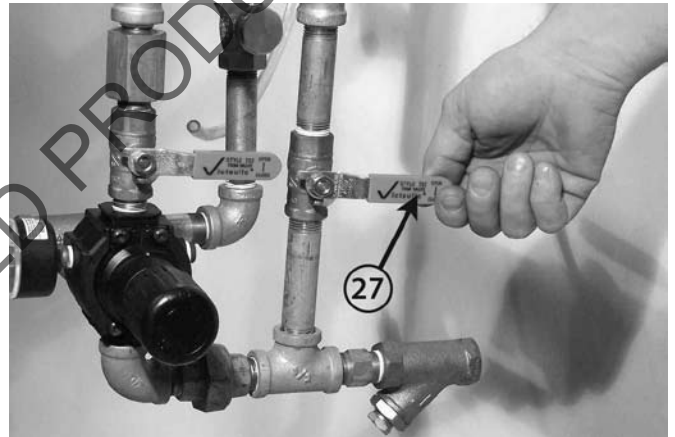

9. When the normal system air pressure is reached, close the fast-fill ball valve on the AMTA (27).

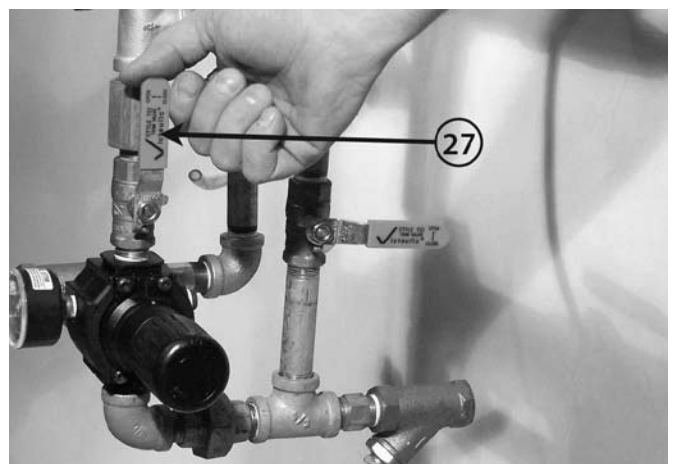

10. Open the slow-fill ball valve on the AMTA (27).

# FireLock® European Dry Valve Stations

SERIES 756  
WITH SERIES 776 LOW-PRESSURE ACTUATOR

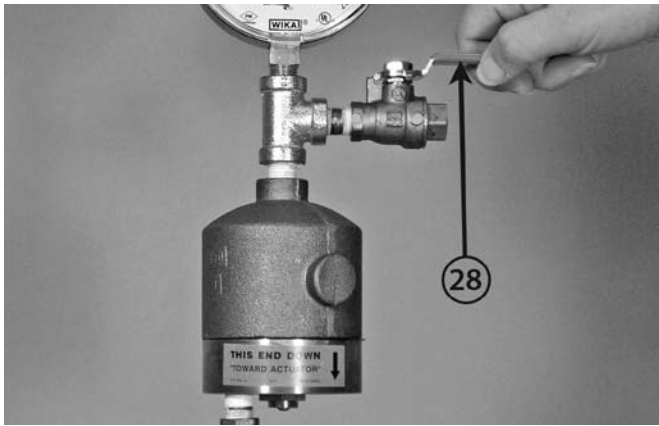

11. If a Series 746-LPA Dry Accelerator (28) is installed, open the ¼-turn vent ball valve.

Manufacturer's Recommended Pressures – Series 746-LPA Dry Accelerator:

- Minimum Water Supply Pressure = 2.0Bar
- Minimum Air Supply Pressure = 1.4Bar
- Minimum Air Supply Pressure = 1.6Bar

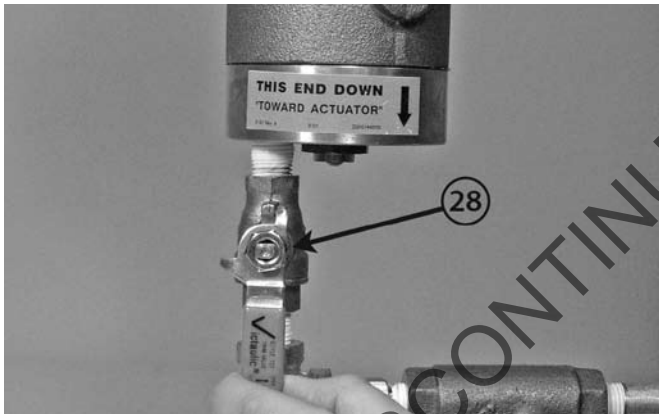

12. If a Series 746-LPA Dry Accelerator (28) is installed, open the isolation ball valve.



13. If a Series 746-LPA Dry Accelerator (28) is installed, close the ¼-turn vent ball valve. This will set the accelerator.

## ⚠ CAUTION

- Take precautions when opening the water supply main control valve, since water will flow from all open system valves. Failure to follow this instruction could result in property damage.



14. Open the water supply main control valve (2) fully.

15. Confirm that all valves are in their normal operating positions (refer to the table below).

Valve	Normal Operating Position
Piston-Charge-Line Ball Valve	Open (Lockable)
Alarm Line Ball Valve	Open (Lockable)
Alarm Test Ball Valve	Closed

16. Notify the authority having jurisdiction, remote station alarm monitors, and those in the affected area that the valve is back in service.
17. Provide test results to the authority having jurisdiction, if required.

# FireLock® European Dry Valve Stations

SERIES 756  
WITH SERIES 776 LOW-PRESSURE ACTUATOR

## REQUIRED OPERATIONAL (TRIP) TESTS

### PARTIAL OPERATIONAL (TRIP) TEST

#### **WARNING**

- The building owner or their representative is responsible for maintaining the fire protection system in proper operating condition.
  - To ensure proper system operation, valves must be inspected in accordance with current national standards or in accordance with the requirements of the local authority having jurisdiction (whichever is more stringent). Always refer to the instructions in this manual for additional inspection and testing requirements.
  - The frequency of inspections must be increased in the presence of contaminated water supplies, corrosive/scaling water supplies, and corrosive atmospheres.
  - Depressurize and drain the piping system before attempting to install, remove, adjust, or maintain any Victaulic products.
- Failure to follow these instructions could cause system failure, resulting in death, serious personal injury, and property damage.**

Partial operational (trip) tests are required at least once a year to confirm proper valve operation; however, this test does not confirm full system operation. Victaulic recommends performing the partial operational (trip) test annually (at minimum). **NOTE:** The frequency of the partial operational (trip) test must be increased in the presence of contaminated water supplies, corrosive/scaling water supplies, and corrosive atmospheres. In addition, the authority having jurisdiction in the area may require partial operational (trip) tests on a more frequent basis. Verify these requirements by contacting the authority having jurisdiction in the affected area.

1. Notify the authority having jurisdiction, remote station alarm monitors, and those in the affected area that the partial operational (trip) test will be performed.
2. Record the system air pressure (7) and water supply pressure (5).

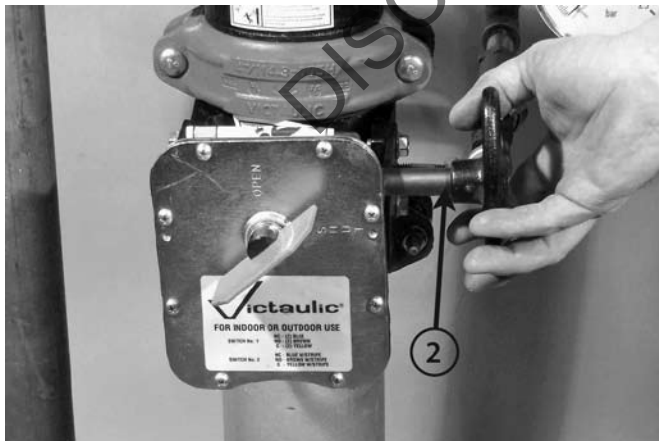

3. Partially close the water supply main control valve (2).

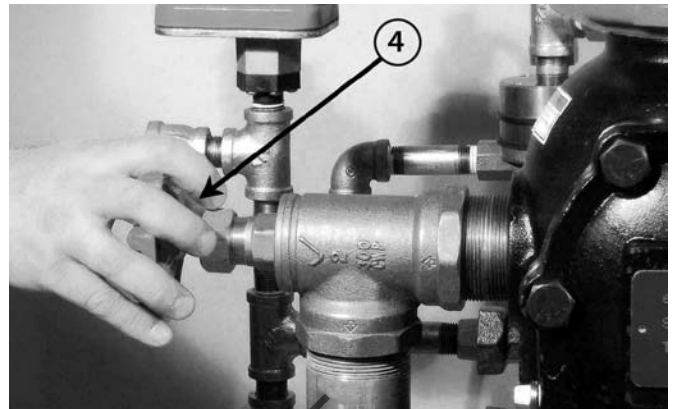

4. Open the remote system test valve (inspector's test connection) or the system main drain valve (4) to simulate an open sprinkler. **NOTE:** The system main drain valve (4) is shown above.
5. Record the system air pressure (7) when the valve operates, along with any other information required by the authority having jurisdiction.
6. Confirm that the piston charge line's pressure drops to zero and that water is flowing through the auto drain (12) to the drip cup (15).



7. Close the water supply main control valve (2) fully.

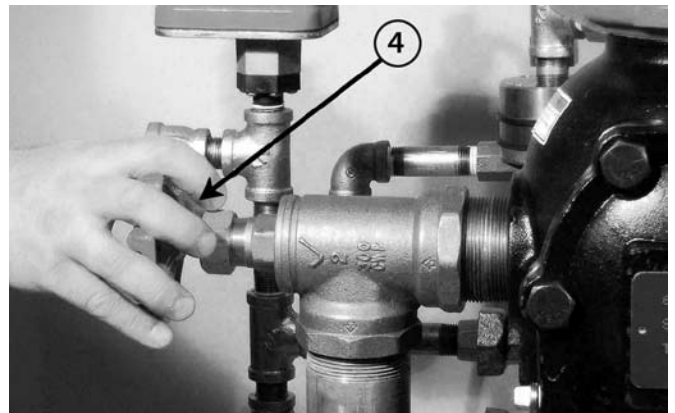

8. Close the remote system test valve (inspector's test connection) or the system main drain valve (4). **NOTE:** The system main drain valve (4) is shown above.

## FireLock® European Dry Valve Stations

SERIES 756

WITH SERIES 776 LOW-PRESSURE ACTUATOR

### 9. SHUT OFF THE AIR SUPPLY.

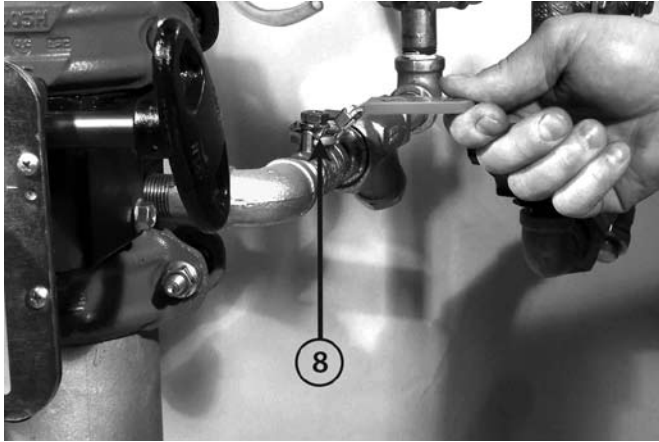

10. Close the piston-charge-line ball valve (8).
11. Perform all steps in the "Placing the System in Service" section, starting on page 11.

### FULL OPERATIONAL (TRIP) TEST

#### **⚠ WARNING**

- The building owner or their representative is responsible for maintaining the fire protection system in proper operating condition.
- To ensure proper system operation, valves must be inspected in accordance with current national standards or in accordance with the requirements of the local authority having jurisdiction (whichever is more stringent). Always refer to the instructions in this manual for additional inspection and testing requirements.
- The frequency of inspections must be increased in the presence of contaminated water supplies, corrosive/scaling water supplies, and corrosive atmospheres.
- Depressurize and drain the piping system before attempting to install, remove, adjust, or maintain any Victaulic products.

**Failure to follow these instructions could cause system failure, resulting in death, serious personal injury, and property damage.**

Victaulic recommends the full operational (trip) test every 3 years (at minimum). **NOTE:** The frequency of the full operational (trip) test must be increased in the presence of contaminated water supplies, corrosive/scaling water supplies, and corrosive atmospheres. This test allows a full flow of water into the sprinkler system; therefore, this test must be performed when there is no chance for freezing conditions. In addition, the authority having jurisdiction in the area may require full operational (trip) tests on a more frequent basis. Verify these requirements by contacting the authority having jurisdiction in the affected area.

1. Notify the authority having jurisdiction, remote station alarm monitors, and those in the affected area that the full operational (trip) tests will be performed.
2. Record the system air pressure (7) and water supply pressure (5).
3. Open the remote system test valve (inspector's test connection) to simulate the operation of a sprinkler.
4. Record the following:
  - 4a. Time between opening the remote system test valve (inspector's test connection) to the operation of the dry valve
  - 4b. System air pressure (7) when the valve operated.
  - 4c. Time from opening the remote system test valve (inspector's test connection) to when water flows from the test connections' outlet
  - 4d. All information required by the authority having jurisdiction
5. Confirm that all alarms operate properly.
6. Continue to run water until it is clear.



# FireLock® European Dry Valve Stations

SERIES 756  
WITH SERIES 776 LOW-PRESSURE ACTUATOR



7. Close the water supply main control valve (2).

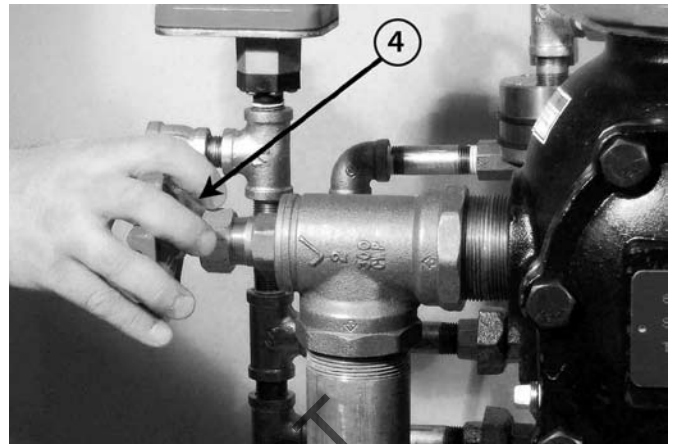

12. Close the system main drain valve (4).

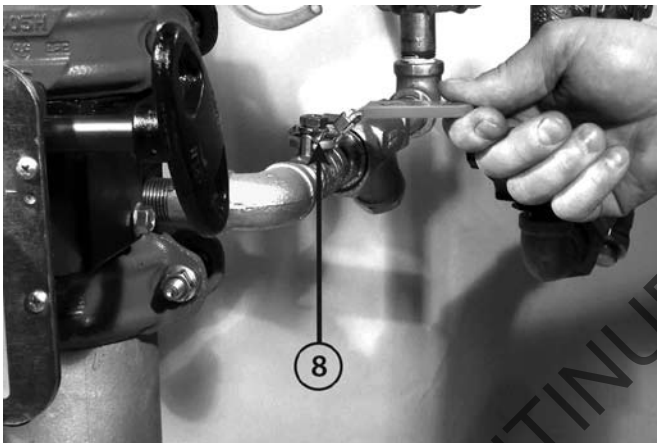

8. Close the piston-charge-line ball valve (8).

9. **SHUT OFF THE AIR SUPPLY.**

13. Perform all steps in the "Placing the System in Service" section, starting on page 11.

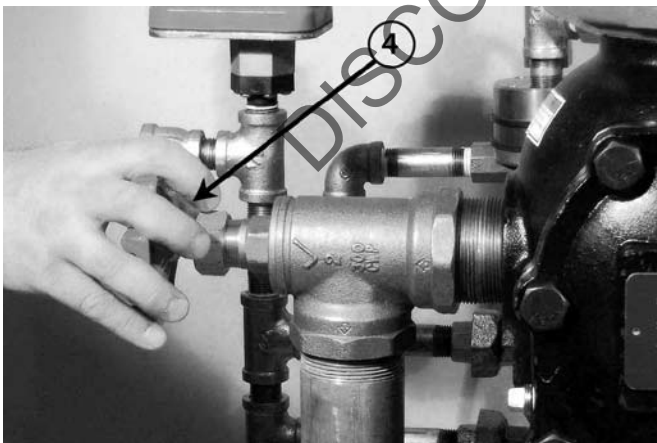

10. Open the system main drain valve (4) to drain the system.

11. After the system is properly drained, close the remote system test valve (inspector's test connection).

# FireLock® European Dry Valve Stations

SERIES 756  
WITH SERIES 776 LOW-PRESSURE ACTUATOR

## REQUIRED INTERNAL INSPECTION

The authority having jurisdiction in the area may have established requirements for internal inspection frequencies. Verify these requirements by contacting the authority having jurisdiction in the affected area.

<b>⚠ WARNING</b>	
	<ul style="list-style-type: none"> <li>Depressurize and drain the piping system before attempting to remove the cover plate from the valve.</li> </ul> <p>Failure to follow this instruction could result in serious personal injury and/or property damage.</p>

<b>⚠ CAUTION</b>	
	<ul style="list-style-type: none"> <li>Any activities that require taking the valve out of service may eliminate the fire protection provided.</li> <li>Before servicing or testing the system, notify the authority having jurisdiction.</li> <li>Consideration of a fire patrol should be given in the affected areas.</li> </ul> <p>Failure to follow these instructions could result in serious personal injury and/or property damage.</p>

1. Notify the authority having jurisdiction, remote station alarm monitors, and those in the affected area that the system is being taken out of service.

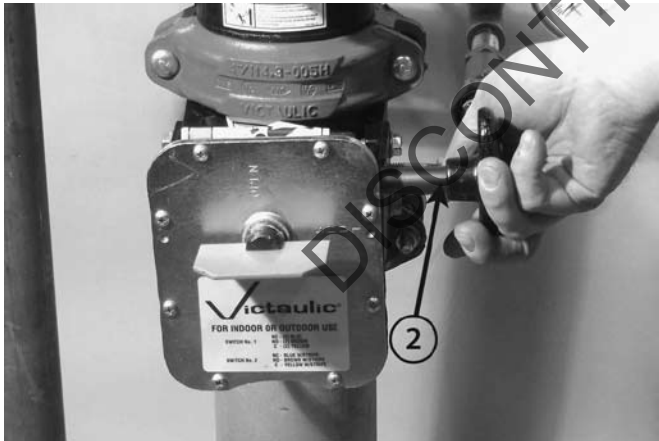

2. Close the water supply main control valve (2) to take the system out of service.

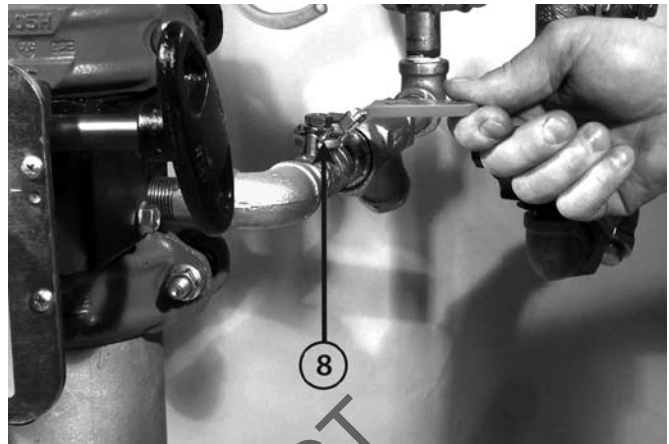

3. Close the piston-charge-line ball valve (8).

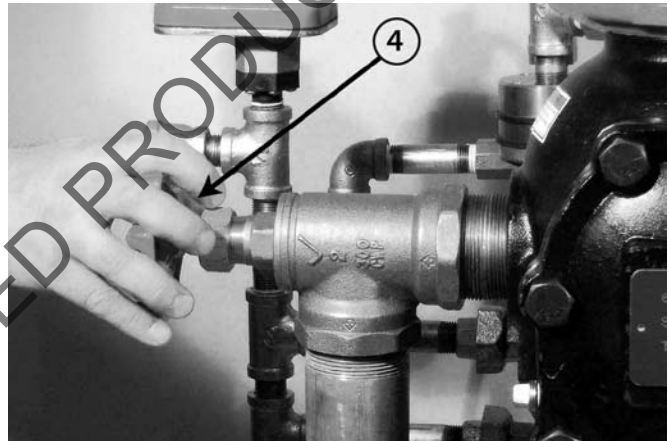

4. Open the system main drain valve (4) to drain any water that has accumulated and to release system air pressure.



**NOTE:** If the system has operated, open the remote system test valve (inspector's test connection) and any auxiliary drain valves.



5. Close the slow-fill ball valve on the AMTA (27).

# FireLock® European Dry Valve Stations

SERIES 756  
WITH SERIES 776 LOW-PRESSURE ACTUATOR

<b>⚠ WARNING</b>	
	<ul style="list-style-type: none"> <li>• Make sure the valve is depressurized and drained completely before the cover plate bolts are removed.</li> </ul>
	<p>The cover plate could blow off if the cover plate bolts are removed while the valve is pressurized, resulting in serious personal injury and/or property damage.</p>

6. **PUSH DOWN ON THE AUTO DRAIN SCREW (12) TO REMOVE PRESSURE IN THE PISTON CHARGE LINE.**
7. After all pressure is released from the system, loosen the cover plate bolts slowly. **NOTE:** DO NOT remove any cover plate bolts until all cover plate bolts are loosened.

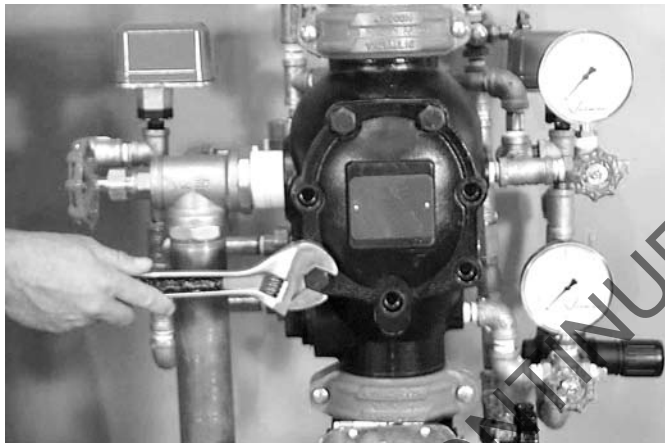

8. Remove all cover plate bolts, along with the cover plate and cover plate gasket.

<b>⚠ CAUTION</b>	
<ul style="list-style-type: none"> <li>• <b>DO NOT</b> use solvents or abrasives on or near the valve body seat ring.</li> </ul> <p>Failure to follow this instruction could prevent the clapper from sealing, resulting in improper valve operation and/or valve leakage.</p>	

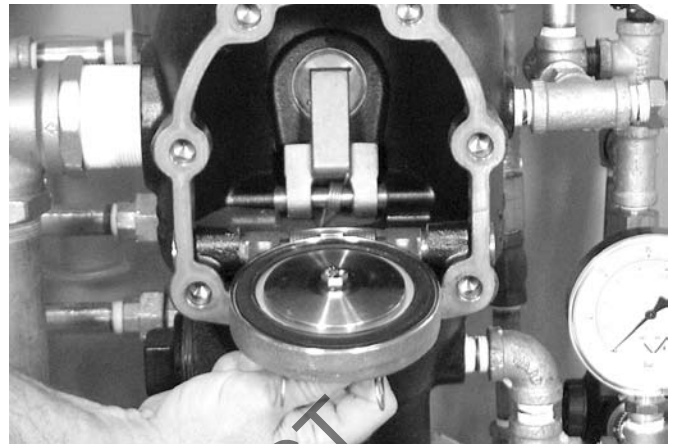

9. Rotate the clapper out of the valve body. Inspect the clapper seal and seal-retaining ring. Wipe away any contaminants, dirt, and mineral deposits. Clean out any holes that are plugged in the valve-body seat ring. **DO NOT USE SOLVENTS OR ABRASIVES.**
10. Inspect the clapper for freedom of movement and physical damage. Replace any damaged or worn parts by following the applicable instructions in the "Maintenance" section, starting on page 32.
11. Re-install the cover plate by following the "Installing the Cover Plate Gasket and Cover Plate" section, starting on page 35.
12. Place the system back in service by following the "Placing the System in Service" section, starting on page 11.

# FireLock® European Dry Valve Stations

SERIES 756  
WITH SERIES 776 LOW-PRESSURE ACTUATOR

## MAINTENANCE

The following sections instruct on how to remove and replace internal valve components. Care must be taken to avoid damage to parts during removal and installation.

<b>⚠ WARNING</b>	
	<ul style="list-style-type: none"> <li>• Depressurize and drain the piping system before attempting to remove the cover plate from the valve.</li> </ul> <p>Failure to follow this instruction could result in serious personal injury and/or property damage.</p>

<b>⚠ CAUTION</b>	
	<ul style="list-style-type: none"> <li>• Any activities that require taking the valve out of service may eliminate the fire protection provided.</li> <li>• Before servicing or testing the system, notify the authority having jurisdiction.</li> <li>• Consideration of a fire patrol should be given in the affected areas.</li> </ul> <p>Failure to follow these instructions could result in serious personal injury and/or property damage.</p>

### REMOVING AND REPLACING THE CLAPPER SEAL

1. Perform steps 1 – 8 of the "Required Internal Inspection" section, starting on page 29.

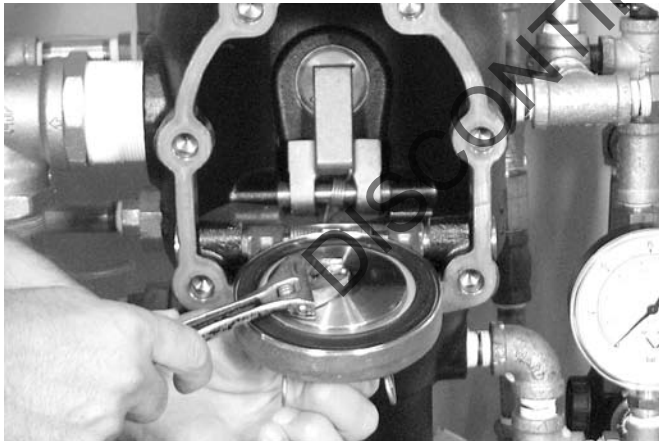

2. Remove the seal assembly bolt/bolt seal from the clapper seal.

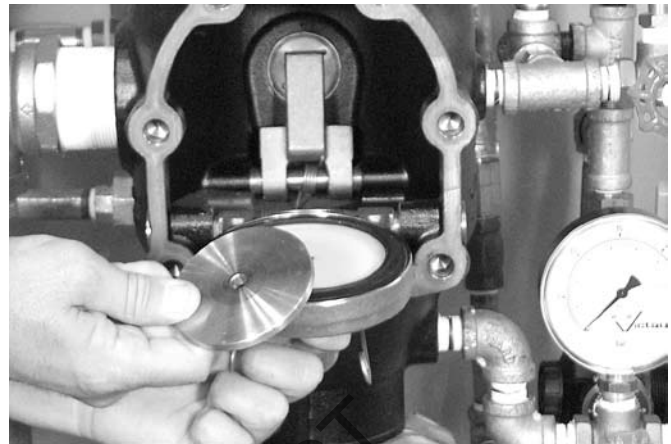

3. Remove the seal-retaining ring.

<b>⚠ CAUTION</b>	
<ul style="list-style-type: none"> <li>• DO NOT pry the seal washer out of the clapper seal from the inner hole.</li> </ul> <p>Failure to follow this instruction could damage the seal washer, resulting in improper clapper sealing and valve leakage.</p>	

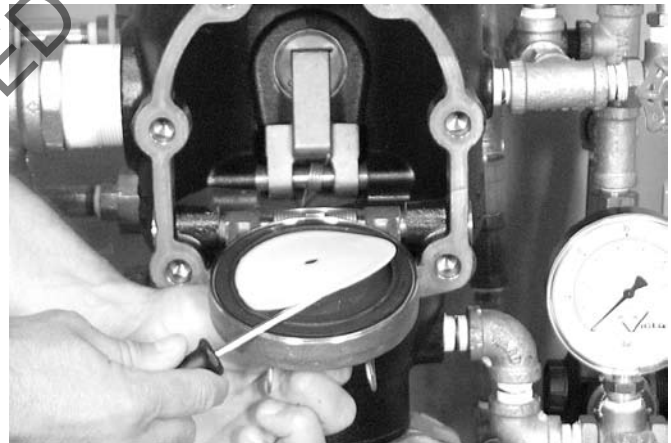

4. Pry the edge of the seal washer from inside the clapper seal, as shown above. **DO NOT PRY THE SEAL WASHER OUT FROM THE INNER HOLE.**
5. Remove the seal washer from the clapper seal. Dry up any moisture that is under the seal washer and on the clapper seal.

<b>⚠ CAUTION</b>	
<ul style="list-style-type: none"> <li>• Use only Victaulic-supplied replacement parts.</li> </ul> <p>Failure to follow this instruction could cause improper valve operation, resulting in property damage.</p>	

# FireLock® European Dry Valve Stations

SERIES 756  
WITH SERIES 776 LOW-PRESSURE ACTUATOR

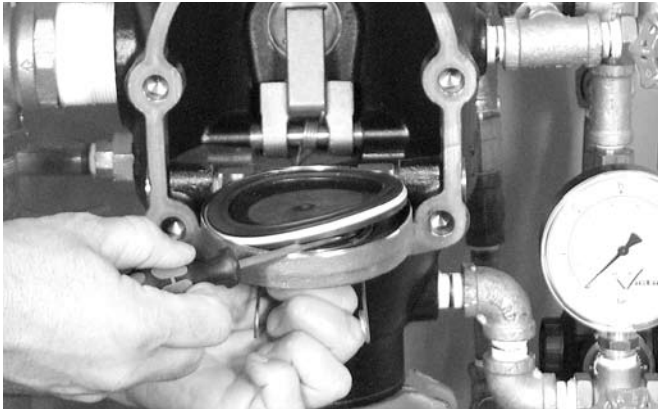

6. Pry the clapper seal, along with the seal ring, out of the clapper. Inspect the clapper seal. If the clapper seal is torn or worn, replace it with a new, Victaulic-supplied clapper seal. If replacing the clapper seal assembly with a new assembly, skip to step 7.

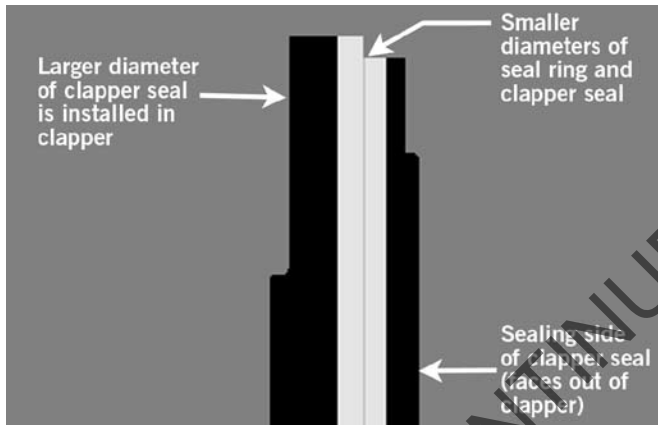

- 6a. If using the same clapper seal assembly and the seal ring was removed from the clapper seal in the previous step: Re-insert the seal ring carefully underneath the outer lip of the clapper seal. Make sure the smaller diameter of the seal ring is toward the sealing surface of the clapper seal.

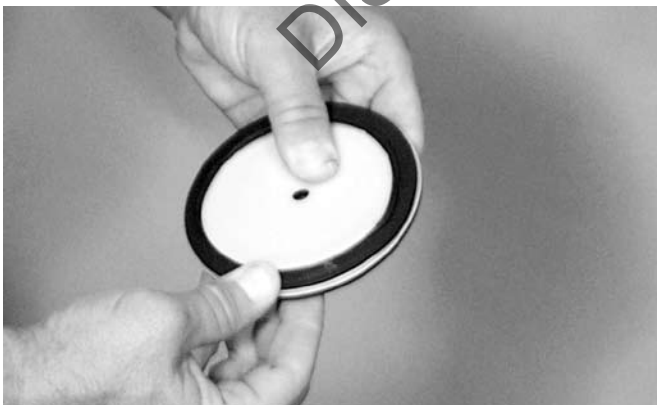

7. Insert the seal washer carefully underneath the sealing lip of the gasket.
8. Remove any contaminants, dirt, and mineral deposits from the clapper.

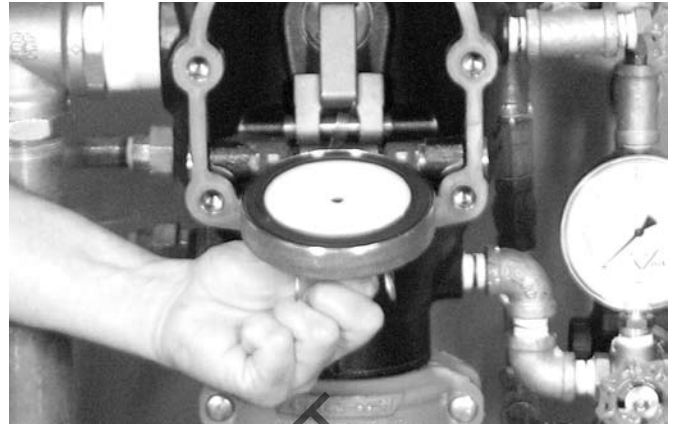

9. Install the clapper seal into the clapper carefully. Make sure the seal ring snaps into the clapper completely.

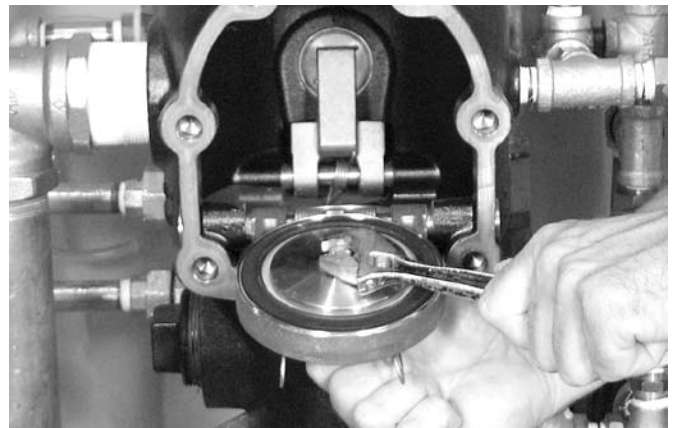
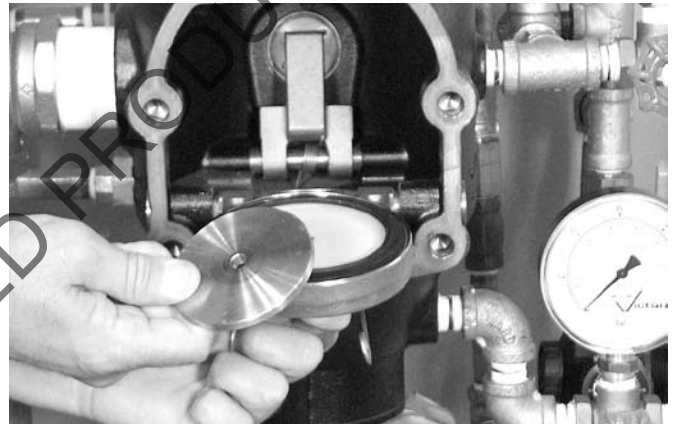

10. Place the seal-retaining ring onto the seal washer of the clapper seal. Install the seal-assembly bolt/bolt seal through the seal-retaining ring and clapper.
  - 10a. Tighten the seal-assembly bolt/bolt seal sufficiently, and apply an additional ¼ turn to ensure a proper seal.
11. Replace the cover plate by following the "Installing the Cover Plate Gasket and Cover Plate" section, starting on page 35.
12. Place the system back in service by following the "Placing the System in Service" section, starting on page 11.

## FireLock® European Dry Valve Stations

### SERIES 756

### WITH SERIES 776 LOW-PRESSURE ACTUATOR

#### REMOVING AND REPLACING THE CLAPPER ASSEMBLY

1. Perform steps 1 – 8 of the "Required Internal Inspection" section, starting on page 29.

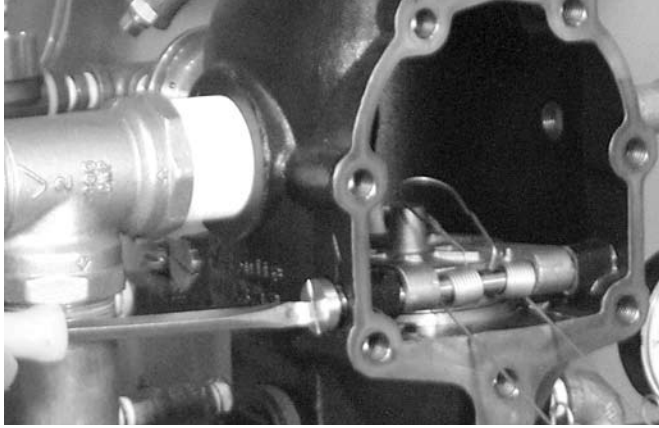

2. Remove one clapper shaft retaining bushing from the valve body.

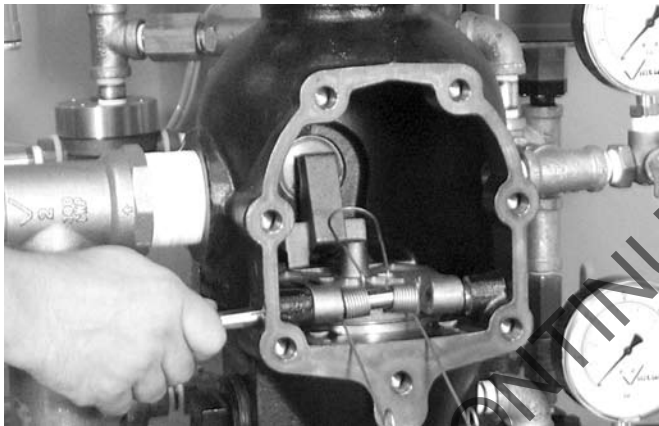

3. Remove the clapper shaft. **NOTE:** As the shaft is being removed, the clapper spring will drop out of position. Keep the clapper spring for re-installation.

- 3a. Remove the clapper from the valve body.

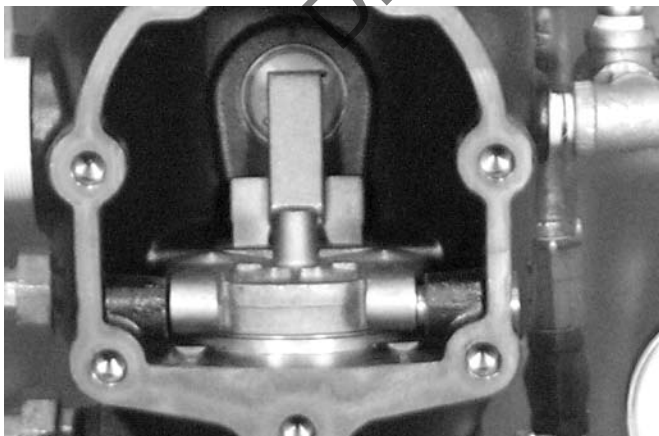

4. Place the new clapper assembly onto the valve-body seat ring. Make sure the holes in the clapper arms align with the holes in the valve body.

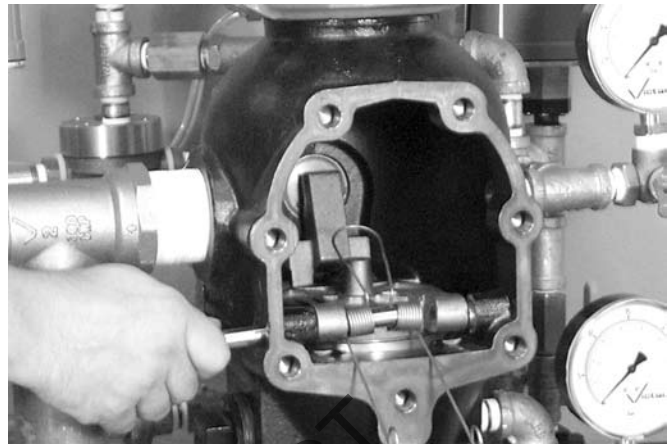

5. Insert the clapper shaft halfway into the valve body.
  - 5a. Install the clapper spring on to the clapper shaft. Make sure the loop of the clapper spring is facing toward the clapper, as shown above.
  - 5b. Finish inserting the clapper shaft through the clapper arm and valve body.

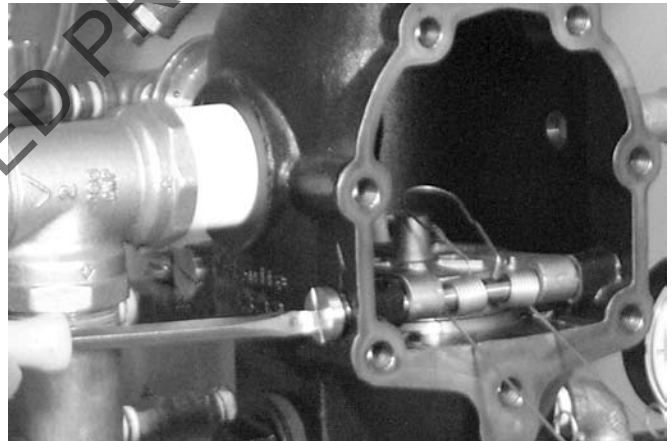

6. Apply thread sealant to the clapper shaft retaining bushing. Install the clapper shaft retaining bushing into the valve body until hand-tight.
  - 6a. Tighten the clapper shaft retaining bushing until metal-to-metal contact occurs with the valve body.
7. Check the clapper for freedom of movement.
8. Replace the cover plate by following the "Installing the Cover Plate Gasket and Cover Plate" section, starting on page 35.
9. Place the system back in service by following the "Placing the System in Service" section, starting on page 11.

# FireLock® European Dry Valve Stations

SERIES 756  
WITH SERIES 776 LOW-PRESSURE ACTUATOR

## INSTALLING THE COVER PLATE GASKET AND COVER PLATE

**CAUTION**

- Use only Victaulic-supplied replacement parts.  
Failure to follow this instruction could cause improper valve operation, resulting in property damage.

1. Verify that the cover plate gasket is in good condition. If the gasket is torn or worn, replace it with a new, Victaulic-supplied gasket.



2. Align the holes of the cover plate gasket with the holes in the cover plate.



3. Insert one cover plate bolt through the cover plate and cover plate gasket to ease alignment.

**CAUTION**

- DO NOT over-tighten the cover plate bolts.  
Failure to follow this instruction could cause damage to the cover plate gasket, resulting in valve leakage.



4. Align the cover plate/cover plate gasket to the valve. Make sure the clapper spring's arms are rotated to their installed position. Tighten all cover plate bolts into the cover plate/valve body.
  - 4a. Torque all cover plate bolts in an even, crossing pattern. Refer to the "Required Cover Plate Bolt Torques" table below for the required torque values. DO NOT over-tighten the cover plate bolts.

**REQUIRED COVER PLATE BOLT TORQUES**

Size	Torque
	N•m
DN80	81
DN100	136
DN150	156
DN200	136

5. Place the system back in service by following the "Placing the System in Service" section, starting on page 11.

# FireLock® European Dry Valve Stations

SERIES 756  
WITH SERIES 776 LOW-PRESSURE ACTUATOR

## REMOVING AND REPLACING THE PISTON ASSEMBLY

### ⚠ CAUTION

- **DO NOT extend the piston manually. Manually extending the piston could damage the internal diaphragm.**  
**Failure to follow this instruction could result in improper valve operation and/or valve leakage.**

1. Remove the system from service by following steps 1 – 6 of the "Required Internal Inspection" section, starting on page 26.
2. Disconnect the trim from the piston. Refer to the applicable trim drawing for details.

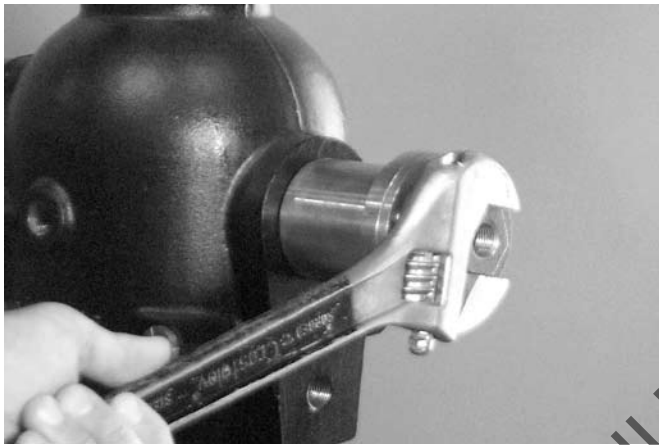

3. Remove the piston from the valve body.
4. Clean the back of the valve body to remove any debris that may interfere with proper piston seating.
5. Replace the piston with a new, Victaulic-supplied assembly. Make sure the o-ring is installed flush to the piston body. Tighten the piston into the valve body until metal-to-metal contact occurs.

### ⚠ CAUTION

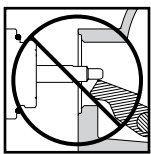

- **Make sure the piston is reinstalled correctly.**  
**Failure to follow this instruction could cause improper valve operation, resulting in property damage.**

6. Re-attach the trim to the piston. Refer to the applicable trim drawing for details.
7. Place the system back in service by following the "Placing the System in Service" section, starting on page 11.

## REPLACING THE STRAINER SCREEN FOR SERIES 776 LOW-PRESSURE ACTUATORS

1. Remove the system from service by following steps 1 – 6 of the "Required Internal Inspection" section, starting on page 29.
2. Remove the Series 776 Low-Pressure Actuator from the trim. Refer to the applicable trim drawing for details.



3. Remove the strainer assembly from the Series 776 Low-Pressure Actuator, as shown above. Discard the strainer screen only.

### ⚠ CAUTION

- **DO NOT re-use strainer screens. After removal, the old strainer screen must be replaced with a new, Victaulic-supplied screen.**

**Failure to follow this instruction could cause improper valve operation, resulting in property damage.**

4. Use only a new, Victaulic-supplied strainer screen. Insert the strainer screen into the strainer assembly.
5. Install the strainer assembly into the Series 776 Low-Pressure Actuator carefully. Avoid damage to the o-ring seals.
6. Re-install the Series 776 Low-Pressure Actuator into the trim. Refer to the applicable trim drawing for details.
7. Place the system in service by following the "Placing the System in Service" section, starting on page 1.



# FireLock® European Dry Valve Stations

**SERIES 756  
WITH SERIES 776 LOW-PRESSURE ACTUATOR**

## TROUBLESHOOTING – SERIES 776 LOW-PRESSURE ACTUATOR

PROBLEM	POSSIBLE CAUSE	SOLUTION
When the Auto Vent Sleeve of the Series 776 Low-Pressure Actuator is pulled up, the screw does not stay set in the "UP" position.	The Series 776 Low-Pressure Actuator is not receiving enough air.	Increase the air pressure going into the Series 776 Low-Pressure Actuator.
	The Series 776 Low-Pressure Actuator has a broken seal.	If the above procedure does not work, contact Victaulic.
Water is leaking through the Series 776 Low-Pressure Actuator.	The air chamber of the Series 776 Low-Pressure Actuator is not set.	Make sure the vent seal of the Series 776 Low-Pressure Actuator is in the set position and the air chamber is pressurized.
	The strainer on the Series 776 Low-Pressure Actuator is clogged.	Replace the strainer screen of the Series 776 Low-Pressure Actuator. Refer to the instructions on page 30.
	The Series 776 Low-Pressure Actuator has a ripped diaphragm.	If water still leaks through the Series 776 after performing the above procedures, contact Victaulic.
No water is passing through the Series 776 Low-Pressure Actuator.	The strainer on the diaphragm charge line is clogged.	Disassemble and clean the diaphragm charge line strainer. Refer to the applicable trim drawing for details.

## TROUBLESHOOTING – SERIES 746-LPA DRY ACCELERATOR

PROBLEM	POSSIBLE CAUSE	SOLUTION
The valve operates without sprinkler activation.	There is a loss of air pressure in the lower inlet chamber of the Series 746-LPA Dry Accelerator.	Check for air loss at the lower chamber seal. If a leak is present, turn the adjustment nut counterclockwise to seal. Check for any leaks in the system and trim. Confirm that the AMTA is operating properly.
	System air pressure exceeds 2 Bar	Decrease system air pressure.
The Series 746-LPA Dry Accelerator does not operate within a 0.3-Bar pressure drop in system air pressure.	There is a loss of air pressure in the upper air chamber of the Series 746-LPA Dry Accelerator.	Apply soapy water to all joints around the Series 746-LPA Dry Accelerator to check for leaks. Repair any leaks and re-test.
	The air decay rate of the system is too slow.	Make sure there are no restrictions in the remote system test valve (inspector's test connection). If the above procedures do not work, contact Victaulic.
The Series 746-LPA Dry Accelerator does not set up properly (cannot get pressure on the upper gauge, and the button pops up immediately when pressure is introduced).	The Series 746-LPA Dry Accelerator is installed upside-down.	Remove the Series 746-LPA Dry Accelerator from the trim, and turn the unit around so that the vent seal "button" is facing down (toward the Series 776 Low-Pressure Actuator).

## TROUBLESHOOTING – SYSTEM

PROBLEM	POSSIBLE CAUSE	SOLUTION
The valve operates without sprinkler activation.	There is a loss of air pressure in the system or trim.	Check for any leaks in the system and trim. Confirm that the AMTA is operating properly. Consider installing a low-air supervisory switch.
	The pressure switch on the air compressor is set too low, or the compressor is not operating properly.	Increase the "ON" setting of the air compressor's pressure switch, and check the air compressor for proper operation.
Water is leaking from the drip check located in the alarm line.	Water is getting past the clapper seal and into the intermediate chamber of the valve.	Check the clapper seal and valve body seat ring for physical damage and foreign material.
	Water is under the clapper seal.	Inspect the clapper seal to make sure no water is under the seal. If water is present, remove and replace the seal. Refer to the instructions on page 32.
Air is leaking from the drip check located in the alarm line.	Air is getting past the clapper seal and into the intermediate chamber of the valve.	Check the clapper seal and valve body seat ring for physical damage and foreign material.
	Water is under the clapper seal.	Inspect the clapper seal to make sure no water is under the seal. If water is present, remove and replace the seal. Refer to the instructions on page 32.
The clapper will not latch closed.	There is no water pressure on the diaphragm.	Check the water pressure in the diaphragm charge line. Make sure the restrictor in the diaphragm charge line is clean.
	The Auto Drain is not set.	Set the Auto Drain by pulling up on the Auto Drain Sleeve.
Water is leaking from the vent hole in the piston assembly.	The diaphragm in the piston is damaged.	Contact Victaulic.
Air is leaking from the vent hole in the piston assembly.	The piston rod seal is damaged.	Contact Victaulic.

t

DISCONTINUED PRODUCT

DISCONTINUED PRODUCT

# FireLock® European Dry Valve Stations

SERIES 756  
WITH SERIES 776 LOW-PRESSURE ACTUATOR

DISCONTINUED PRODUCT

#### US & WORLD HEADQUARTERS

P.O. Box 31  
Easton, PA 18044-0031 USA

4901 Kesslersville Road  
Easton, PA 18040 USA

1-800-PICK-VIC (1-800-742-5842)  
1-610-559-3300  
1-610-250-8817 (fax)  
pickvic@victaulic.com

[www.victaulic.com](http://www.victaulic.com)

#### CANADA

905-884-7444  
905-884-9774 (fax)  
viccanada@victaulic.com

#### EUROPE

32-9-381-15-00  
32-9-380-44-38 (fax)  
viceuro@victaulic.be

#### UNITED KINGDOM

44 (0) 1438741100  
44 (0) 1438313883 (fax)  
viceuro@victaulic.be

#### CENTRAL AND SOUTH AMERICA

1-610-559-3300  
1-610-559-3608 (fax)  
vical@victaulic.com

#### ASIA PACIFIC

86-21-54253300  
86-21-54253671 (fax)  
vicap@victaulic.com

#### MIDDLE EAST

971-4-883-88-70  
971-4-883-88-60 (fax)



WCAS-6M8PRY

UPDATED 4/2006

I-756LPA.VDS 3813 REV B Z000756VPA

VICTAULIC IS A REGISTERED TRADEMARK OF VICTAULIC COMPANY. © 2006 VICTAULIC COMPANY. ALL RIGHTS RESERVED. PRINTED IN THE USA.

I-756LPA.VDS

