



Victaulic® VicFlex™ Style VS1 Dry Sprinkler

⚠ WARNING





- Read and understand all instructions before attempting to install any Victaulic® VicFlex™ Style VS1 Dry Sprinklers.
- Wear safety glasses, hardhat, and foot protection.
- These installation instructions are intended for an experienced, trained installer.
- The installer must understand the use of this product and why it was specified for the particular application.
- The installer must understand common industry safety standards and potential consequences of improper product installation.

Failure to follow these instructions could cause improper sprinkler operation, resulting in death or serious personal injury and property damage.

TECHNICAL DATA

⚠ WARNING

- It is the system designer's responsibility to verify suitability of stainless steel components for use with the intended fluid media within the piping system and external environment.
- The material specifier must evaluate the effect of chemical composition, pH level, operating temperature, chloride level, and oxygen level on stainless steel components to confirm system life will be acceptable for the intended service.

Failure to follow these instructions could cause product failure, resulting in serious personal injury and/or property damage.

Maximum Working Pressure Rating:
175 psi/12 Bar/1207 kPa (UL Listing)

Connection to Branch Line (Inlet):
1 inch/25 mm NPT or BSPT

Minimum Bend Radius:
2 inch/50 mm (UL Listing)

K-Factor of Sprinkler:
5.6 US/80 metric

Maximum Number of 90° Bends:
4 Bends (UL Listing)

BEND CHARACTERISTICS

NOTE: For out-of-plane (three-dimensional) bends, care must be taken to avoid imparting torque on the assembly.

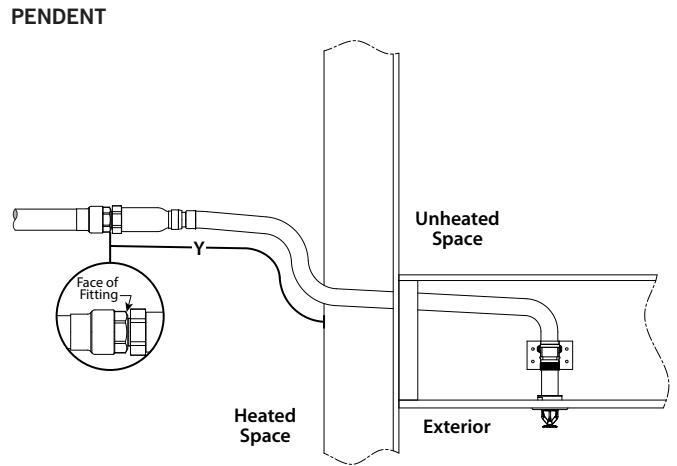
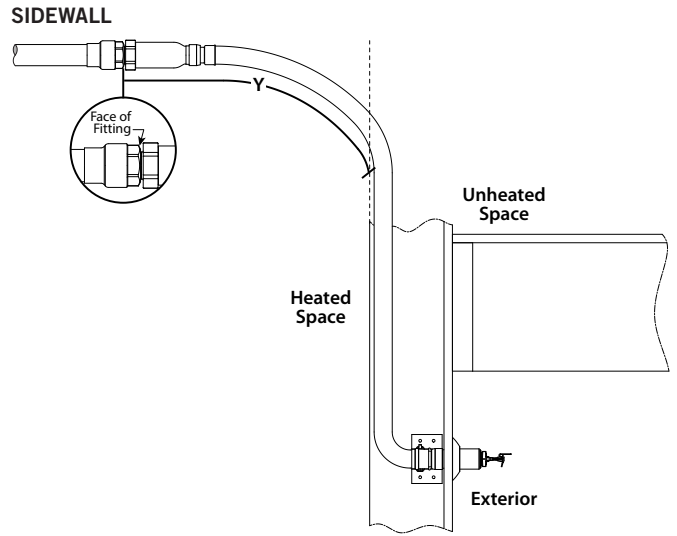
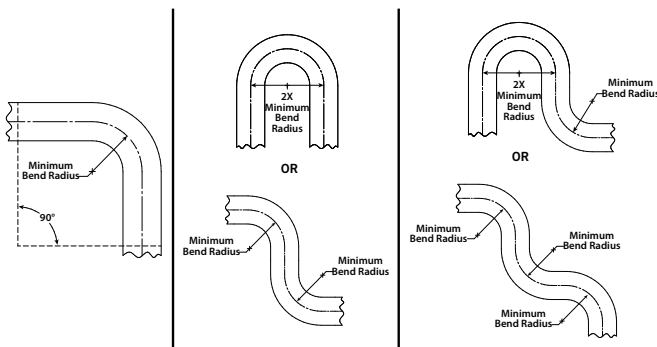

The following table is used when the ambient temperature is maintained between 40°F/4°C and 60°F/16°C around the wet piping system.

Ambient Temperature Exposed to Discharge End of Sprinkler °F/°C	Exposed Minimum Barrel Length "Y" inches/mm		
	40°F/4°C	50°F/10°C	60°F/16°C
40	0	0	0
4	0	0	0
30	0	0	0
-1	0	0	0
20	4	0	0
-7	100	0	0
10	8	1	0
-12	200	25	0
0	12	3	0
-18	300	75	0
-10	14	4	1
-23	350	100	25
-20	14	6	3
-29	350	150	75
-30	16	8	4
-34	400	200	100
-40	18	8	4
-40	450	200	100
-50	20	10	6
-46	500	250	150
-60	20	10	6
-51	500	250	150

NOTE: Exposed minimum barrel lengths are inclusive up to 30-mph/48-kph wind velocities

IMPORTANT INSTALLATION INFORMATION

- Victaulic® VicFlex™ Style VS1 Dry Sprinklers must be installed according to current, applicable National Fire Protection Association (NFPA 13, 13D, 13R, etc.) standards or equivalent standards. Victaulic® VicFlex™ Style VS1 Dry Sprinklers are intended to be installed in wet, dry, or preaction actuated systems. Deviations from these standards or alterations to Victaulic® VicFlex™ Style VS1 Dry Sprinklers will void any Victaulic warranty. In addition, installations must meet provisions of the local authority having jurisdiction and local codes, as applicable.
- Transport and store Victaulic® VicFlex™ Style VS1 Dry Sprinklers in a cool, dry environment in their original packaging.
- **Refer to the specific product submittal for applications and listing information. These submittals are located in Sections 10 and 40 of the Victaulic G-100 Catalog or on the Victaulic website at victaulic.com.**
- Size the piping system to provide the minimum operating pressure of 7 psi/0.5 Bar/48 kPa.
- Per NFPA requirements, flush the system to remove foreign material. Continue to flush the system until water runs clear.
- **DO NOT** install sprinkler system piping through heating ducts.
- **DO NOT** connect sprinkler system piping to domestic hot water systems.
- **DO NOT** install Victaulic® VicFlex™ Style VS1 Dry Sprinklers where they will be exposed to temperatures that exceed the maximum ambient temperature rating for the product.
- **Victaulic® VicFlex™ Style VS1 Dry Sprinklers have limited flexibility and are intended only to be installed with bends not less than their respective minimum bend radii.**
- Protect wet piping systems from freezing temperatures.
- If construction is altered, refer to applicable standards to determine if additional Victaulic® VicFlex™ Style VS1 Dry Sprinklers are required.
- **DO NOT** install Victaulic® VicFlex™ Style VS1 Dry Sprinklers that have been dropped or struck by another object, even if they do not appear damaged. Never install glass bulb sprinklers if the bulb is cracked or if there is a loss of liquid from the bulb. Discard and replace any Victaulic® VicFlex™ Style VS1 Dry Sprinklers that are damaged or show signs of corrosion.
- Before installation, verify that the Victaulic® VicFlex™ Style VS1 Dry Sprinkler is the proper style, orifice size, and temperature rating for the intended service.
- **VICTAULIC® VICFLEX™ STYLE VB2 BRACKET ASSEMBLIES SHALL BE USED ONLY WITH STYLE VS1 RECESSED PENDENT SPRINKLERS.**
- **VICTAULIC® VICFLEX™ STYLE VB3 BRACKET ASSEMBLIES SHALL BE USED ONLY WITH STYLE VS1 CONCEALED PENDENT SPRINKLERS.**
- **DO NOT** paint, coat, plate, or alter Victaulic® VicFlex™ Style VS1 Dry Sprinklers. Victaulic® VicFlex™ Style VS1 Dry Sprinklers that have been altered from their manufactured condition may not function properly and will void any agency listings and/or approvals.
- **DO NOT** test Victaulic® VicFlex™ Style VS1 Dry Sprinklers with a heat source. The glass bulb can weaken or shatter if exposed to a heat source during testing.
- Victaulic® VicFlex™ Style VS1 Dry Sprinklers that have operated cannot be reassembled or reused, per NFPA requirements. When replacing sprinklers, use new sprinklers of the same type, orifice, temperature, and response.
- **DO NOT** clean Victaulic® VicFlex™ Style VS1 Dry Sprinklers with soapy water, detergents, ammonia, cleaning fluids, or other chemicals. Remove any dust, lint, etc. with a soft, dry cloth.
- Inspect Victaulic® VicFlex™ Style VS1 Dry Sprinklers on a regular basis for corrosion, mechanical damage, obstructions, etc. The frequency of inspections may vary due to corrosive atmospheres/water supplies and activities around the sprinklers.
- **DO NOT** hang anything from or attach anything to Victaulic® VicFlex™ Style VS1 Dry Sprinklers. Obstructing the discharge pattern will prevent the sprinkler from operating properly.
- The owner is responsible for maintaining the fire protection system in proper operating condition.
- For minimum maintenance and inspection requirements, refer to NFPA 25 and any other applicable NFPA standards that describe the care and maintenance of sprinkler systems. In addition, the authority having jurisdiction may have additional maintenance, testing, and inspection requirements that must be followed.

WARNING

- **Replacement/relocation of this Victaulic® VicFlex™ Style VS1 Dry Sprinkler MUST be performed by qualified personnel familiar with the system's original design criteria, sprinkler listings/approvals, and state and local codes (including NFPA 13 standards).**

Failure to replace/relocate Victaulic® VicFlex™ Style VS1 Dry Sprinklers properly could affect their performance during a fire, resulting in serious personal injury and property damage.

STYLE VS1 SPRINKLER ASSEMBLY DRAWING

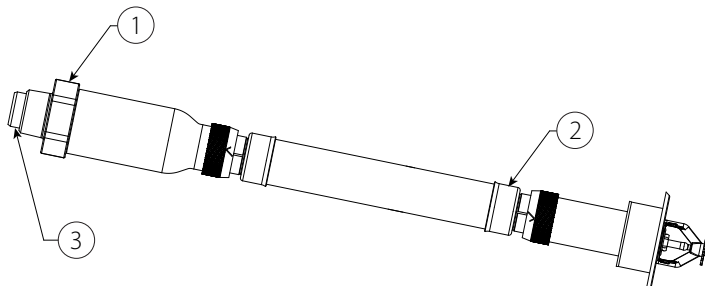

Recessed Pendent Shown Above

Item	Description
1	Swivel Hex Nut
2	Weld Fitting
3	Inlet

STYLE VB1 BRACKET ASSEMBLY DRAWING

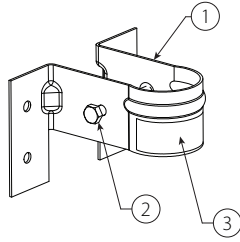

Item	Description
1	Style VB1 Bracket
2	Hex Cap Screw
3	Relocation Warning Label

STYLE VB2 BRACKET ASSEMBLY DRAWING

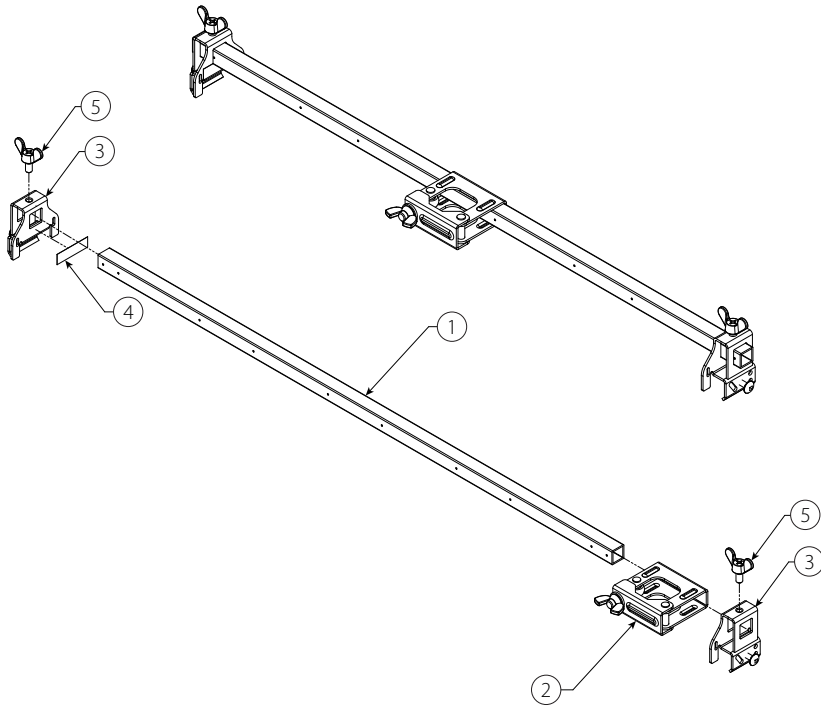

Item	Description
1	24-inch/610-mm or 48-inch/1219-mm Square Bar*
2	Center Gate Assembly with Wing Nut
3	Style VB2 End Bracket with Tapping Screw
4	Relocation Warning Label
5	Wing Screw

* Reference submittal document VS-10.91 for listing information. Square bar length is in reference to nominal ceiling grid spacing.

NOTICE

- VICTAULIC® VICFLEX™ STYLE VB2 BRACKET ASSEMBLIES SHALL BE USED ONLY WITH STYLE VS1 RECESSED PENDENT SPRINKLERS.

STYLE VB3 BRACKET ASSEMBLY DRAWING

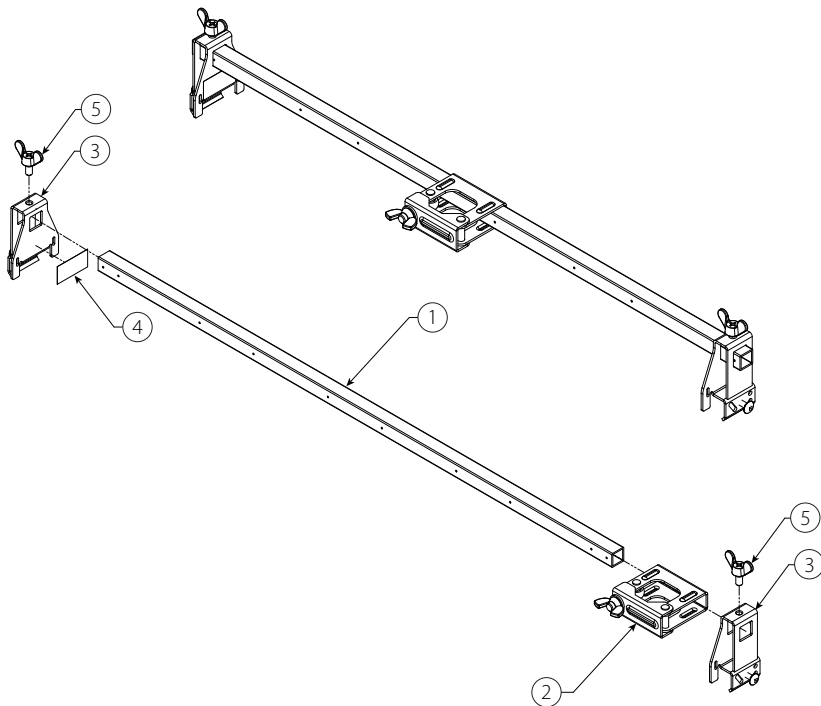

Item	Description
1	24-inch/610-mm or 48-inch/1219-mm Square Bar*
2	Center Gate Assembly with Wing Nut
3	Style VB3 End Bracket with Tapping Screw
4	Relocation Warning Label
5	Wing Screw

* Reference submittal document VS-10.91 for listing information. Square bar length is in reference to nominal ceiling grid spacing.

NOTICE

- VICTAULIC® VICFLEX™ STYLE VB3 BRACKET ASSEMBLIES SHALL BE USED ONLY WITH STYLE VS1 CONCEALED PENDENT SPRINKLERS.

STYLE VS1 SPRINKLER ASSEMBLY PITCHING REQUIREMENTS

SIDEWALL

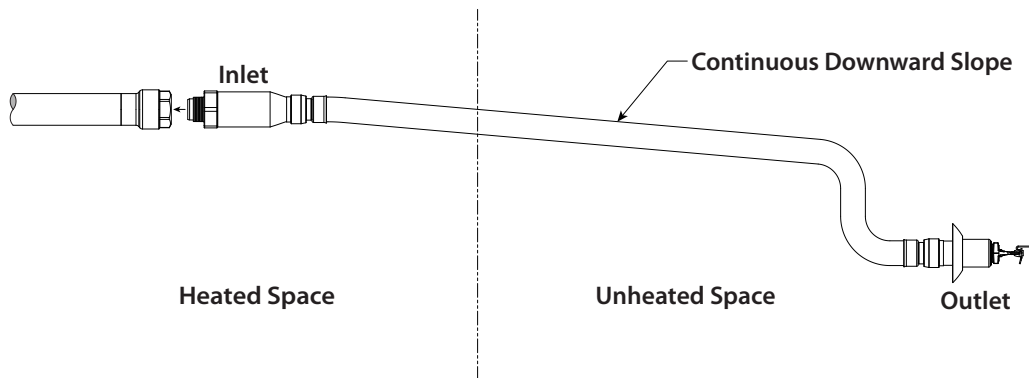

ACCEPTABLE PITCH

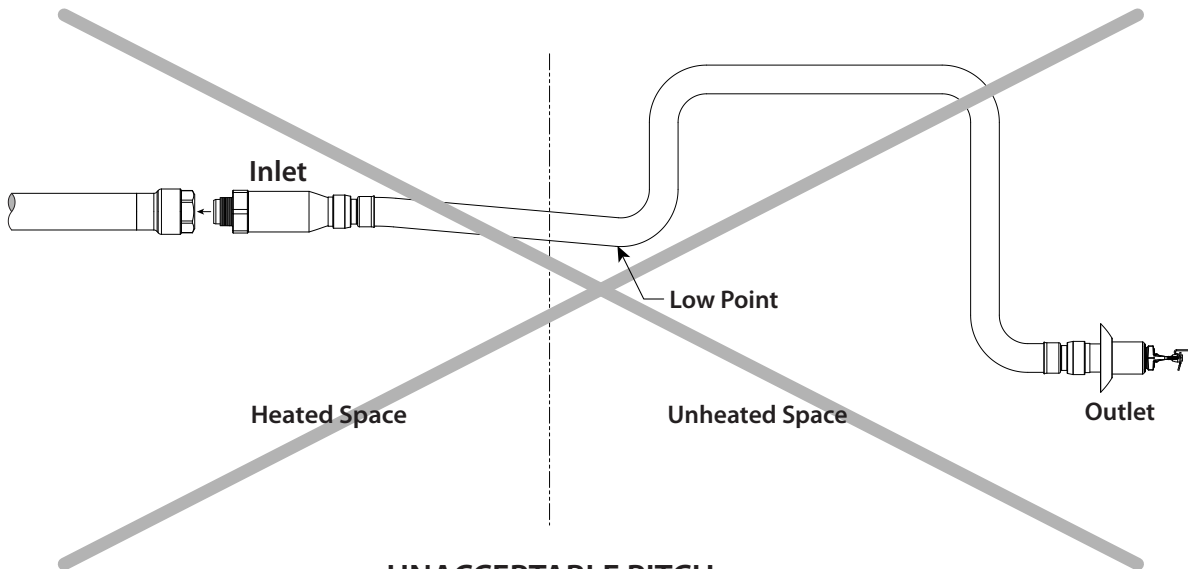

UNACCEPTABLE PITCH

FOR DRY SYSTEMS ONLY:

- The Style VS1 Dry Sprinkler's inlet shall be installed only into the outlet of a cast or malleable iron tee that meets the dimensional requirements of ANSI B16.3 and ANSI B16.4, Class 125 and Class 150. Use a sample fitting to confirm proper engagement.



Style VS1 Dry Sprinklers in dry systems must be installed with a continuous downward slope along its entire length from the branch line fitting to the sprinkler. No localized low points shall be present along the length of the Style VS1 Dry Sprinkler.

Style VS1 Dry Sprinklers are not permitted to be installed into the top of the branch line piping. Style VS1 Dry Sprinklers must be installed into the side or from the bottom of the branch line piping.

FOR WET SYSTEMS ONLY:

- **DO NOT** install Victaulic® VicFlex™ Style VS1 Dry Sprinklers into couplings or threaded elbows.
- **DO NOT** install Victaulic® VicFlex™ Style VS1 Dry Sprinklers into any fitting that interferes with thread penetration. The inlet of the Victaulic® VicFlex™ Style VS1 Dry Sprinkler **MUST NOT** bottom out in the fitting. Use a sample fitting to confirm proper engagement.
- To ensure unobstructed flow during operation, the Victaulic® VicFlex™ Style VS1 Dry Sprinkler must be installed into a fitting that will prevent water and debris from accumulating at the dry sprinkler's inlet.



In a wet system, if a portion of the Style VS1 Dry Sprinkler extends into an unconditioned space, it must be installed with a continuous downward slope along the entire exposed length from the inside wall to the sprinkler. No localized low points shall be present along the exposed length of the sprinkler.

STYLE VS1 SPRINKLER ASSEMBLY PITCHING REQUIREMENTS (CONTINUED)

PENDENT

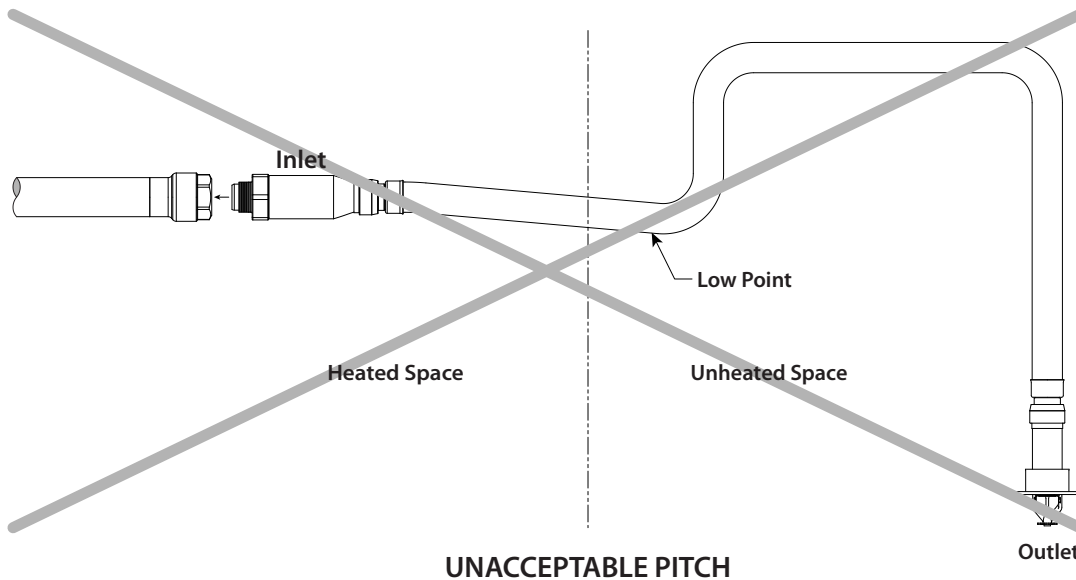
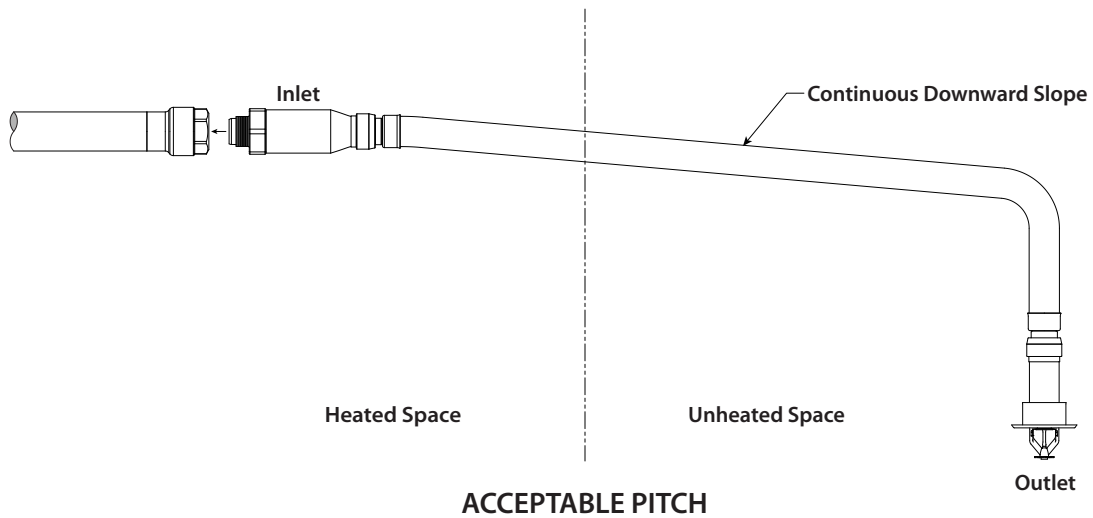

FOR DRY SYSTEMS ONLY:

- The Style VS1 Dry Sprinkler's inlet shall be installed only into the outlet of a cast or malleable iron tee that meets the dimensional requirements of ANSI B16.3 and ANSI B16.4, Class 125 and Class 150. Use a sample fitting to confirm proper engagement.



Style VS1 Dry Sprinklers in dry systems must be installed with a continuous downward slope along its entire length from the branch line fitting to the sprinkler. No localized low points shall be present along the length of the Style VS1 Dry Sprinkler.

Style VS1 Dry Sprinklers are not permitted to be installed into the top of the branch line piping. Style VS1 Dry Sprinklers must be installed into the side or from the bottom of the branch line piping.

FOR WET SYSTEMS ONLY:

- **DO NOT** install Victaulic® VicFlex™ Style VS1 Dry Sprinklers into couplings or threaded elbows.
- **DO NOT** install Victaulic® VicFlex™ Style VS1 Dry Sprinklers into any fitting that interferes with thread penetration. The inlet of the Victaulic® VicFlex™ Style VS1 Dry Sprinkler **MUST NOT** bottom out in the fitting. Use a sample fitting to confirm proper engagement.
- To ensure unobstructed flow during operation, the Victaulic® VicFlex™ Style VS1 Dry Sprinkler must be installed into a fitting that will prevent water and debris from accumulating at the dry sprinkler's inlet.



In a wet system, if a portion of the Style VS1 Dry Sprinkler extends into an unconditioned space, it must be installed with a continuous downward slope along the entire exposed length from the inside wall to the sprinkler. No localized low points shall be present along the exposed length of the sprinkler.

STYLE VB1 BRACKET INSTALLATION FOR WOOD OR METAL JOISTS/STUDS

WARNING

- DO NOT attempt to adjust or remove a Victaulic® VicFlex™ Style VS1 Dry Sprinkler while the sprinkler system is pressurized.

Failure to follow this instruction could result in death or serious personal injury and property damage.

1. Cut a hole in the finished ceiling or wall. Refer to the table below for hole sizes.

Minimum and Maximum Hole Sizes

Sprinkler Style	Hole Sizes – inches/millimeters	
	Minimum	Maximum
VS1 Recessed	2	2 ³ / ₈
	51	60
VS1 Concealed	2 ⁵ / ₈	2 ³ / ₄
	67	70
VS1 Sleeve/Skirt	1 ³ / ₄	2 ¹ / ₂
	44	64



2. Apply a non-hardening pipe-joint compound or two to three wraps of PTFE thread sealant tape to the male threads of the Style VS1 Dry Sprinkler's inlet, in accordance with the pipe joint compound or tape manufacturer's instructions.

- 2a. Using a 2-inch wrench, tighten the swivel hex nut at the Style VS1 Dry Sprinkler's inlet to a torque of 30 ft-lbs/41 N•m (approximately 1/2 to 3/4 of a turn past hand-tight).



3. Using a 5/16-inch hex socket, remove the hex cap screw from the bracket.

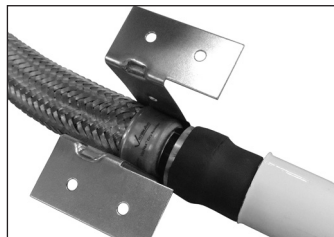

4. Snap the bracket onto the weld fitting, as shown to the left. Make sure the slot of the bracket aligns with the lip on the weld fitting.

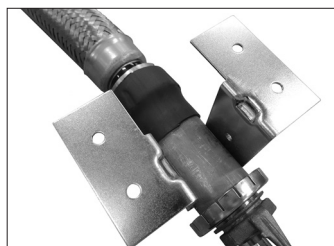

- An alternative to step 4 is to snap the bracket onto the outlet tube, as shown.



5. Place the bracket assembly in the desired position on the wood or metal joist/stud. Make sure the sprinkler orientation is in the proper position.

- 5a. Using a 5/16-inch hex socket, re-install the hex cap screw. Tighten the hex cap screw to 15 inch-lbs/1.7 N•m (approximately one to two turns past hand-tight). This will retain the sprinkler orientation in relation to the bracket mounting flanges.

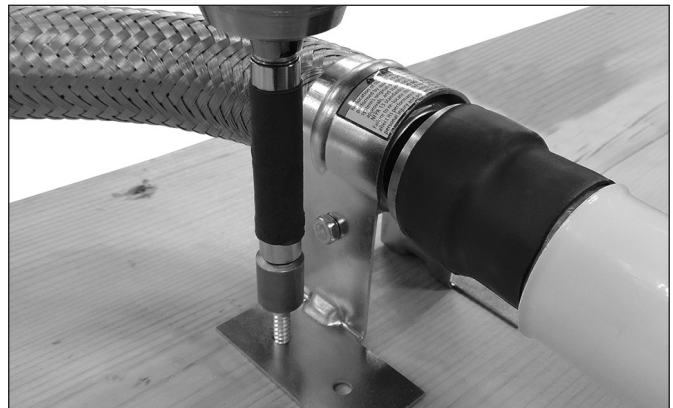

6. Anchor the bracket in the desired location on the wood or metal joist/stud by using two #10 x 1 1/2-inch long wood screws (for wood joists/studs shown above) or two #10 x 1 1/2-inch long sheet metal screws (for metal joists/studs). **NOTE:** Victaulic does not supply wood screws or sheet metal screws.

NOTICE

- Style VS1 Dry Sprinklers in dry systems must be installed with a continuous downward slope along its entire length from the branch line fitting to the sprinkler. No localized low points shall be present along the length of the Style VS1 Dry Sprinkler.
- Style VS1 Dry Sprinklers in dry systems are not permitted to be installed into the top of the branch line piping. Style VS1 Dry Sprinklers must be installed into the side or from the bottom of the branch line piping.
- Style VS1 Dry Sprinklers in wet systems, installed where a portion extends into an unconditioned space, must be installed with a continuous downward slope along the entire exposed length from the inside wall to the sprinkler. No localized low points shall be present along the exposed length of the sprinkler.

**STYLE VB2 AND STYLE VB3 BRACKETS –
INSTALLATION FOR ASTM C635 CEILING
SUSPENSION SYSTEMS INSTALLED WITH
LAY-IN TILES (IN ACCORDANCE WITH
ASTM C636 STANDARDS)**

⚠ WARNING

- **DO NOT** attempt to adjust or remove a Victaulic® VicFlex™ Style VS1 Dry Sprinkler while the sprinkler system is pressurized. Failure to follow this instruction could result in death or serious personal injury and property damage.

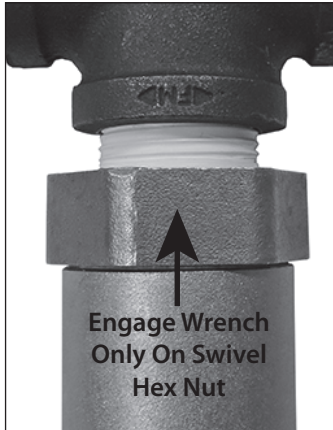

1. Apply a non-hardening pipe-joint compound or two to three wraps of PTFE thread sealant tape to the male threads of the Style VS1 Dry Sprinkler's inlet, in accordance with the pipe joint compound or tape manufacturer's instructions.
- 1a. Using a 2-inch wrench, tighten the swivel hex nut at the Style VS1 Dry Sprinkler's inlet to a torque of 30ft-lbs/41 N•m (approximately ½ to ¾ of a turn past hand-tight).



For adjustment purposes, the wing screw on top of each end bracket assembly can be loosened to allow the end bracket to slide on the square bar. Tighten the wing screw on top of each end bracket assembly to a torque of 36 inch-lbs/4 N•m (approximately ½ to ¾ of a turn past hand-tight) to secure the end bracket to the square bar.

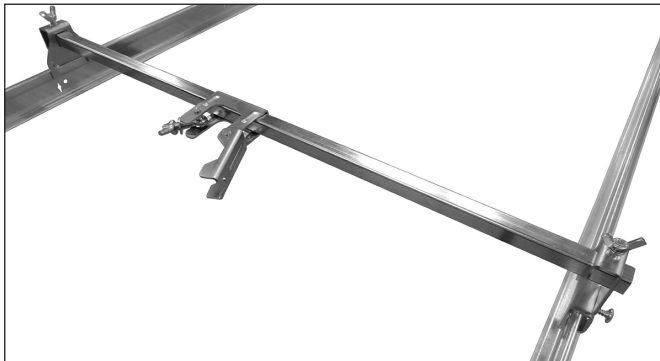

2. Attach the end brackets of the Style VB2 Bracket to the T-bar rails of an ASTM C635 ceiling suspension system installed in accordance with ASTM C636 standards. Make sure the ends of the Style VB2 Bracket engage the rails.

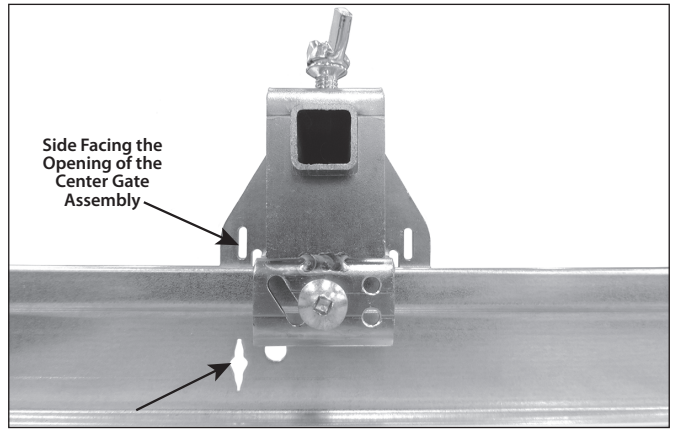

- 2a. For center-of-tile installations, align the end bracket with the center-of-tile slot of the T-bar rail (with the side facing the opening of the center gate assembly), as shown above.

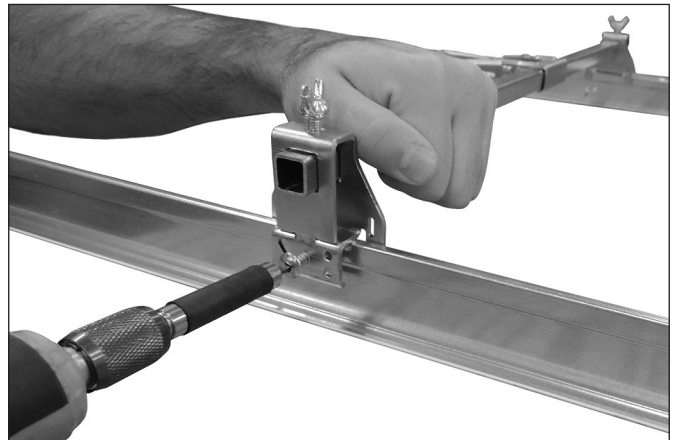

- 2b. Apply light downward pressure, as shown above, to maintain the position of the end bracket flat against the T-bar rail. To secure the end brackets to the T-bar rails, tighten the pre-installed sheet metal screws using a #2 recessed square drive bit. Penetrate through the T-bar rail until the end bracket is seated fully against the T-bar rail. **DO NOT over-tighten the screws. Over-tightening will cause the screw to strip, resulting in an unsecured bracket connection.**



3. Move the center gate assembly of the Style VB2 Bracket to the desired location. Loosen the wing nut to open the center gate assembly, then slide the sprinkler reducing nipple into the center gate assembly. **NOTE:** The pivot screw of the center gate assembly is staked to resist removal of the wing nut.

Victaulic® VicFlex™ Style VS1 Dry Sprinkler

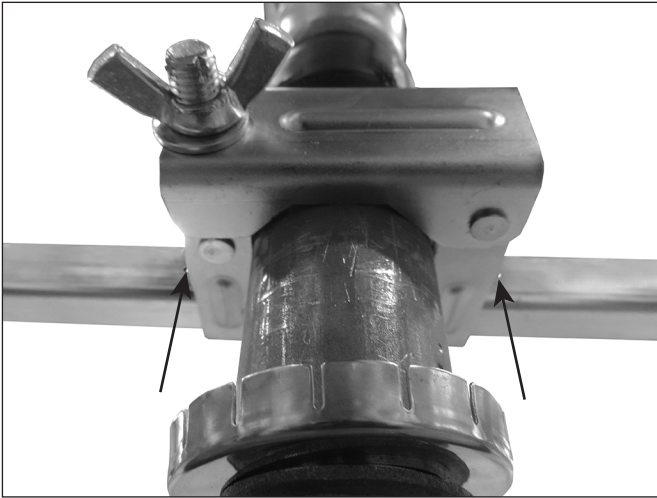

For center-of tile installations, position the center gate assembly between the two reference marks on the square bar, as shown above.



- 3a. Close the center gate assembly around the sprinkler reducing nipple. Swing the pivot screw and washer into the slot on the gate, and tighten the wing nut to a torque of 50 inch-lbs/6 N•m (approximately hand-tight, plus $\frac{1}{2}$ to $\frac{3}{4}$ of a turn). **NOTE:** Make sure the washer is seated under the head of the wing nut.

For complete contact information, visit victaulic.com

I-VICFLEX.VS1 8919 REV C UPDATED 05/2016 Z000VS1000

VICTAULIC AND VICFLEX ARE REGISTERED TRADEMARKS OR TRADEMARKS OF VICTAULIC COMPANY AND/OR ITS AFFILIATED ENTITIES IN THE UNITED STATES AND/OR OTHER COUNTRIES. © 2016 VICTAULIC COMPANY. ALL RIGHTS RESERVED.

