

VE436MC Roll Grooving Tool Slide Upgrade Kit

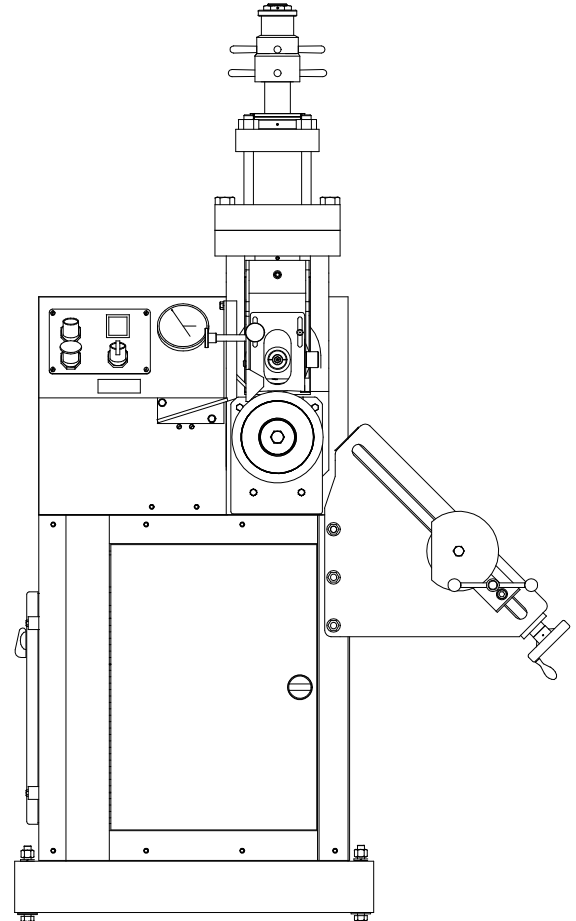

PARTS ORDERING INFORMATION

When ordering parts, the following information is necessary for Victaulic to process the order promptly:

1. Tool Model Number – VE436MC
2. Tool Serial Number – The Serial Number can be found on the side of the tool.
3. Quantity, Item Number, Part Number, Description
4. Where to send the part(s) – Company Name and Address
5. To whose attention to send the part(s)
6. Purchase Order Number

Parts may be ordered from your nearest Victaulic Sales Office.

VE436MC Roll Grooving Tool Slide Upgrade Kit

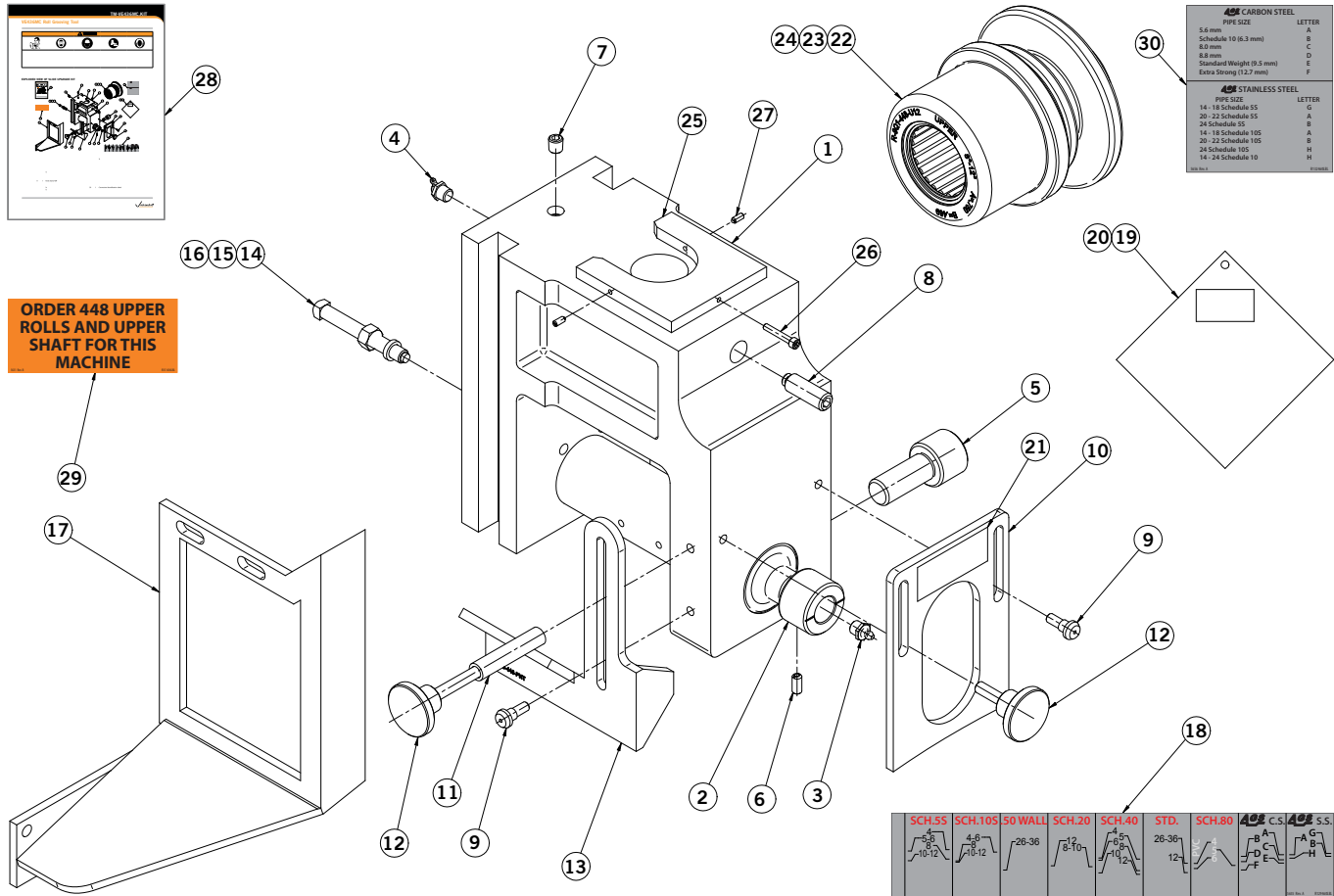

Item#	Part #	Qty.	Description
1	R-102-448-MCH	1	Slide
2	R-105-448-MCH	1	Upper Shaft
3	N-M01-000-002	1	Lubrication Fitting
4	N-M01-000-001	1	Lubrication Fitting
5	R-122-448-PLT	1	Upper Shaft Pin
6	N-M12-000-002	1	Ball Plunger
7	N-H16-002-001	1	1/8" Flush Socket Pressure Plug
8	N-S80-080-100	1	Set Screw, 1/2 - 13 UNC x 1.0 Lg. Brass Tip, Blk. Ox.
9	R-131-448-PLT	2	Guard Retaining Stud
10	R-130-448-PNT	1	Front Sliding Guard
11	R-127-448-PNT	1	Knob Stand-Off
12	N-M04-000-007	2	Knob
13	R-123-448-PNT	1	Sliding Guard
14	N-S89-060-300	2	Pilot Pt. Sq. Hd. Set Screw, 3/8-16 UNC x 3.0 Lg. Blk. Ox.
15	N-N01-060-000	2	Hex Nut, 3/8 - 16 UNC, Pltd.
16	N-W05-060-000	2	3/8" Hi-Collar Lock Washer, Blk. Ox.

Item#	Part #	Qty.	Description
17	R-036-448-PNT	1	Roll Guard
18	R-129-460-LBL	1	Pipe Size Indicator Label
19	R-039-272-0FS	1	Guard Setting Pad Assembly for Original Groove System (OGS)
20	R-077-416-ASY	1	Guard Setting Pad Assembly for Advanced Groove System (AGS)
21	R-040-416-LAB	1	Pipe Rotation Label
22	R-9Q1-448-ASY	1	Upper Roll Assembly, 4 - 6" OGS Steel
23	R-9Q1-448-ASY	1	Upper Roll Assembly, 8 - 12" OGS Steel
24	R-WQ2-448-ASY	1	Upper Roll Assembly, 14 - 24" AGS Steel
25	R-108-436-VE0	1	Slide Spacer
26	N-S03-008-100	1	#8 - 32 UNC x 1.0 Lg. Socket Head Cap Screw, Blk. Ox.
27	N-M12-000-004	2	Ball Plunger
28	5573	1	TM-VE436MC.KIT Slide Upgrade Kit Instructions
29	R-151-436-LBL	1	Conversion Identification Label
30	R-132-460-LBL	1	AGS Pipe Size Reference Label

For complete contact information, visit www.victaulic.com

RP-VE436MC.KIT 5633 REV A UPDATED 04/2009 RPL0436KIT

VICTAULIC IS A REGISTERED TRADEMARK OF VICTAULIC COMPANY. © 2009 VICTAULIC COMPANY. ALL RIGHTS RESERVED. PRINTED IN THE USA.

RP-VE436MC.KIT

