

VE436MC Roll Grooving Tool

⚠ WARNING



- Read and understand all instructions before attempting to operate, adjust, or maintain any Victaulic grooving tools.
 - Always disconnect the tool from the power source before attempting to perform maintenance on any components.
 - Wear safety glasses, hardhat, foot protection, and hearing protection when working with tools.
- Failure to follow these instructions could result in serious personal injury and product damage.

The following instructions detail removal of the original-style slide and installation of the upgraded slide kit, which allows the operator to use “Quick Change” upper rolls. Always refer to the operating and maintenance instructions manual for complete setup and operating requirements.

EXPLODED VIEW OF SLIDE UPGRADE KIT

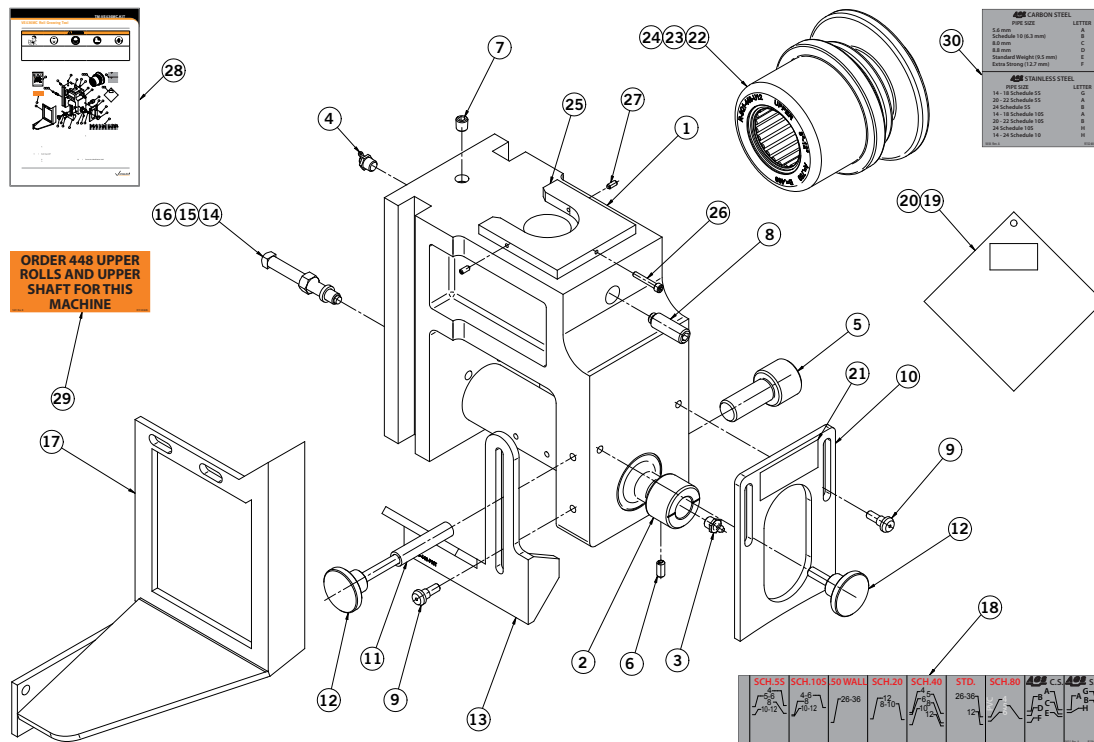

Bill of Materials

Item	Qty.	Description	Item	Qty.	Description
1	1	Slide	16	2	3/8-inch Hi-Collar Lock Washer
2	1	Upper Shaft	17	1	Roll Guard
3	1	Lubrication Fitting	18	1	Pipe Size Indicator Label
4	1	Lubrication Fitting	19	1	Guard Setting Pad for Original Groove System (OGS)
5	1	Upper Shaft Pin	20	1	Guard Setting Pad for Advanced Groove System (AGS)
6	1	Ball Plunger	21	1	Pipe Rotation Label
7	1	1/8-inch Flush Socket Pressure Plug	22	1	4 - 6-inch OGS Steel Upper Roll Assembly
8	1	1/2-13UNC x 1.50-inch Long Set Screw	23	1	8-12-inch OGS Steel Upper Roll Assembly
9	2	Guard Retaining Stud	24	1	14-24-inch AGS Steel Upper Roll Assembly
10	1	Front Sliding Guard	25	1	Slide Spacer
11	1	Knob Stand-Off	26	1	#8-32UNC x 1.00-inch Long Socket Head Cap Screw
12	2	Knob	27	2	Ball Plunger
13	1	Sliding Guard	28	1	TM-VE436MC.KIT Slide Upgrade Kit Instructions Sheet
14	2	3/8-16UNC x 3.0-inch Long Pilot Pt. Sq. Hd. Set Screw	29	1	Conversion Identification Label
15	2	3/8-16UNC Hex Nut	30	1	AGS Pipe Size Reference Label

* Refer to the RP-VE436MC.KIT Repair Parts List for a complete listing of part numbers for the above-listed components.

VE436MC Roll Grooving Tool

VE436MC TOOL HEAD ASSEMBLY

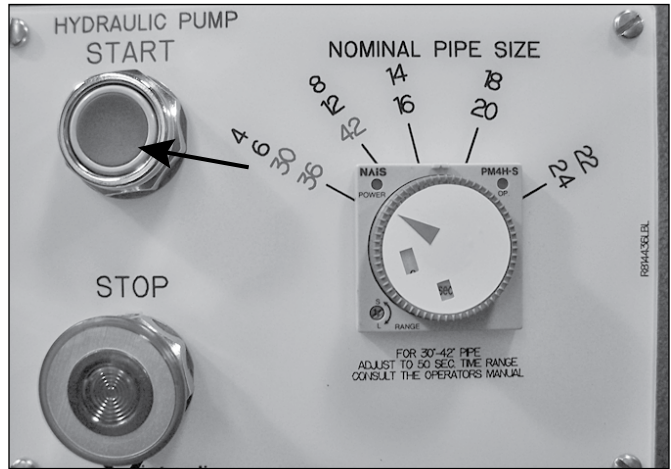
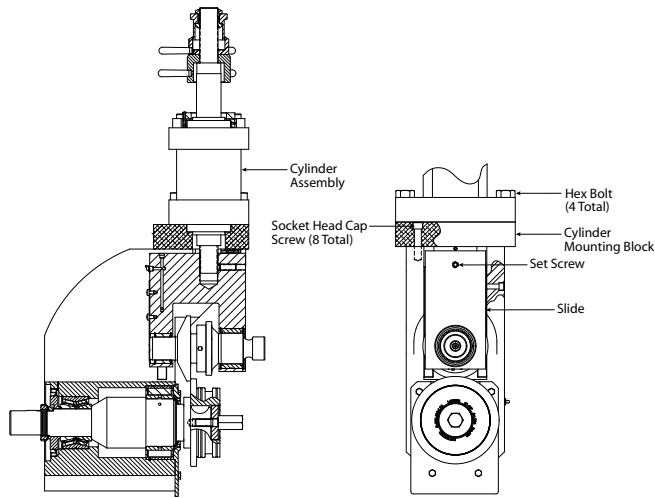

4. Push the "HYDRAULIC PUMP START" button.

REMOVING THE EXISTING ROLL SET

1. Turn on the main power supply to the tool (main breaker panel, knife switch, etc.).



2. Turn the power switch on the side of the tool to the "ON" position.

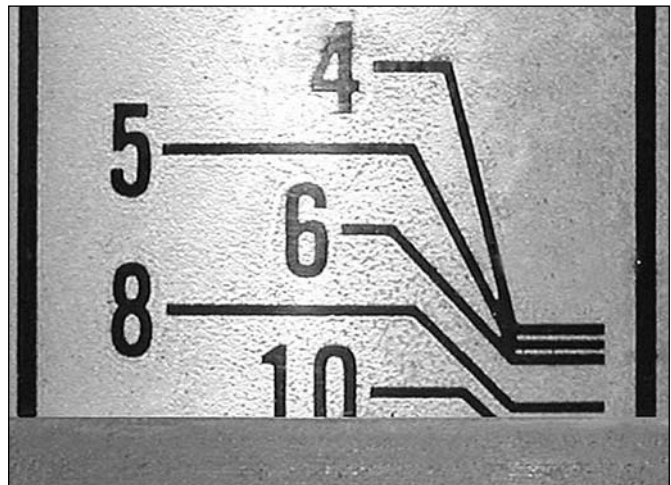

5. Rotate the depth adjuster to the setting for nominal size 8-inch Schedule 40 pipe, as shown above.

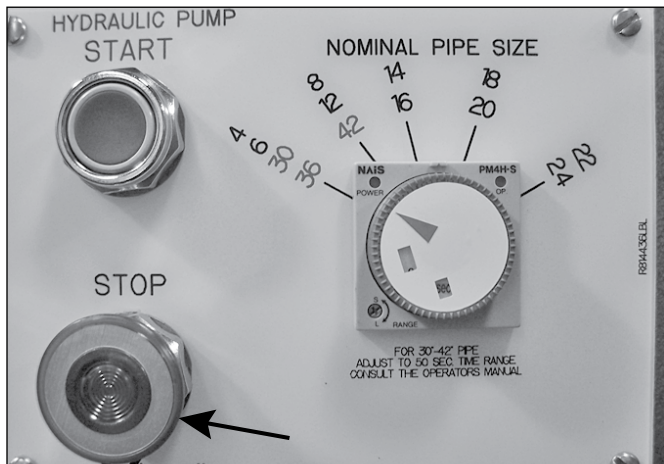

3. Pull the red "STOP" knob to the out position.

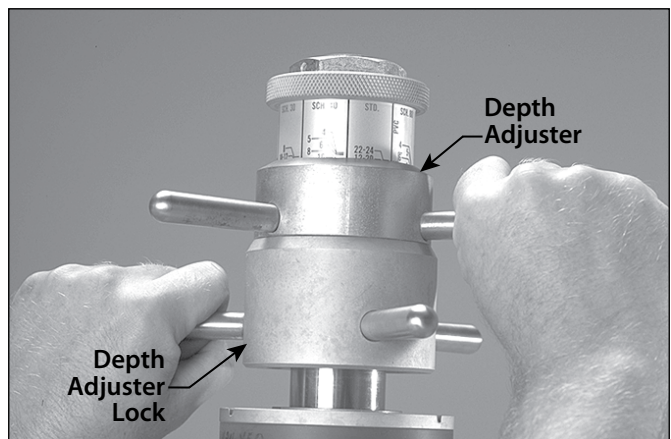

6. Hold the depth adjuster to prevent it from turning. Turn the depth adjuster lock clockwise to lock it with the depth adjuster.

VE436MC Roll Grooving Tool

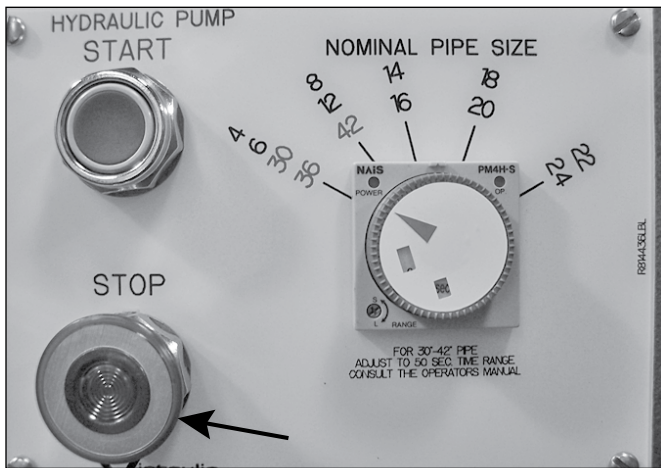
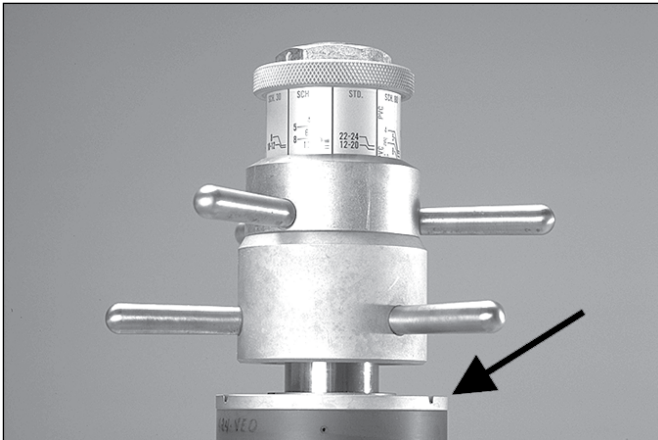

7. Depress the safety foot switch. When the groove diameter stop contacts the hydraulic cylinder, push down (in) on the red "STOP" knob. Release the safety foot switch, and withdraw foot from switch.



8. Remove the slide spacer by snapping it out directly, as shown above.

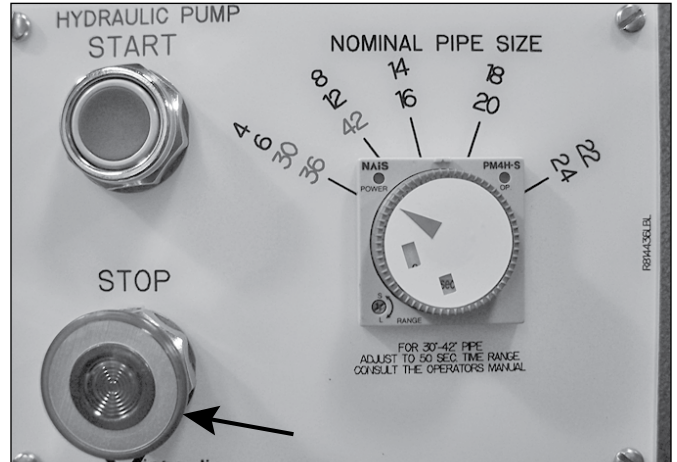

9. Pull the red "STOP" knob to the out position.

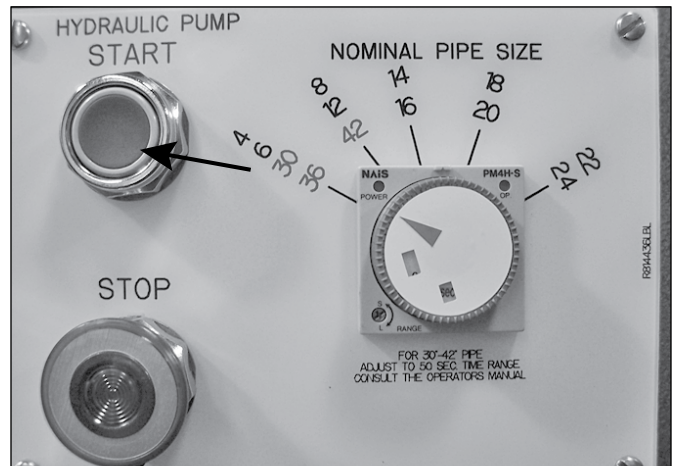

10. Push the "HYDRAULIC PUMP START" button to retract (raise) the slide.

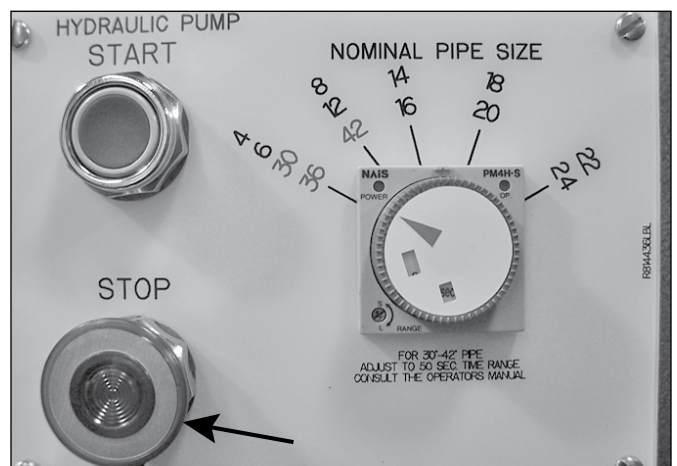

11. After the slide is retracted (raised) completely, push down (in) on the red "STOP" knob.

VE436MC Roll Grooving Tool



12. Turn the power switch on the side of the tool to the “OFF” position.

WARNING

- Always turn off the main power supply to the tool before making any tool adjustments.

Failure to follow this instruction could result in death or serious personal injury.

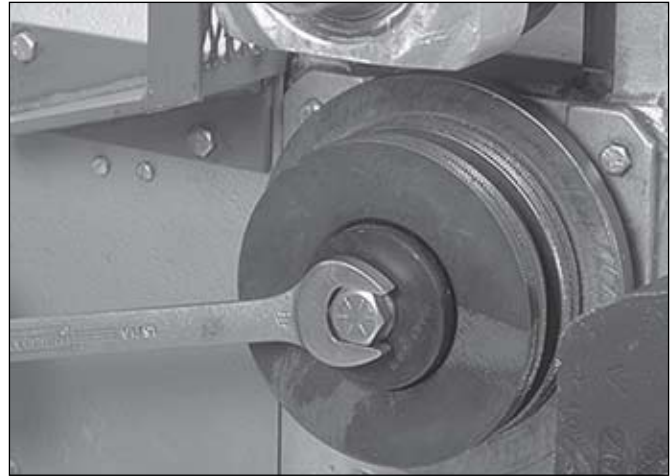

14. Using a $\frac{1}{16}$ -inch wrench, remove the $\frac{5}{8}$ -inch bolt and washer that secures the lower roll.

NOTICE

- Be careful not to lose the Woodruff Key. The Woodruff Key should remain in the lower shaft.
- If the Woodruff Key shows signs of damage, replace it with a new, Victaulic-supplied key.

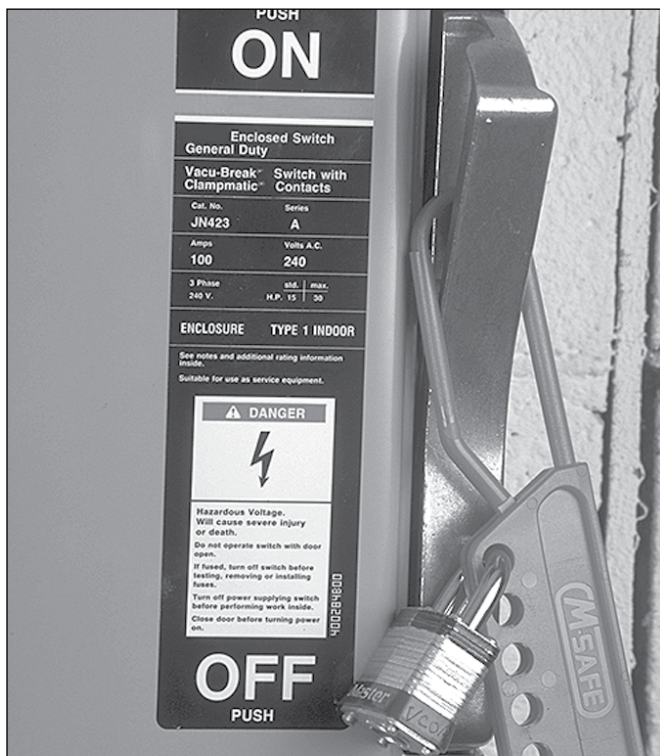

13. Turn off the main power supply to the tool (main breaker panel, knife switch, etc.). Lock the switch in the “OFF” position to prevent accidental engagement. **NOTE:** Victaulic does not supply this lockout mechanism.

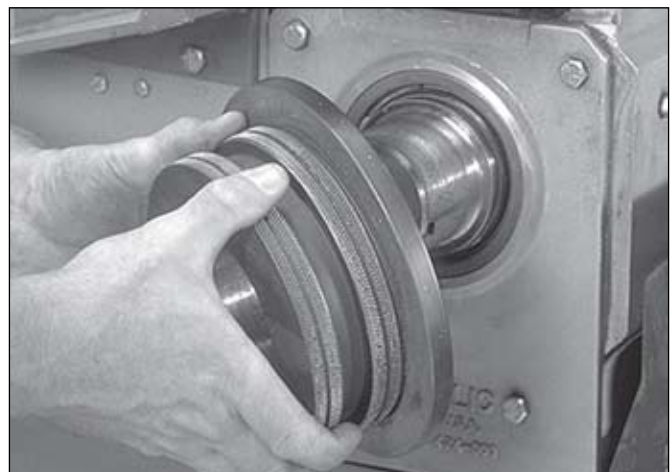

15. Pull the lower roll off the main shaft. Store the lower roll inside the tool cabinet. If the lower roll cannot be removed by hand, use a conventional gear puller. Be careful not to lose the Woodruff Key.

VE436MC Roll Grooving Tool

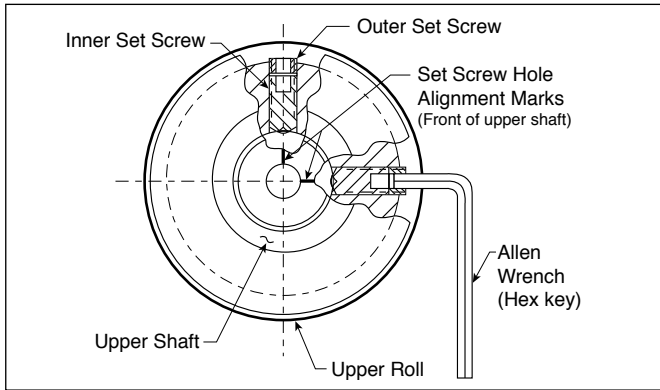

FIGURE 1

- Loosen the upper roll by inserting the 3/16-inch allen wrench (supplied) into each outer set screw, as shown in Figure 1 above. Loosen each outer set screw approximately half a turn.

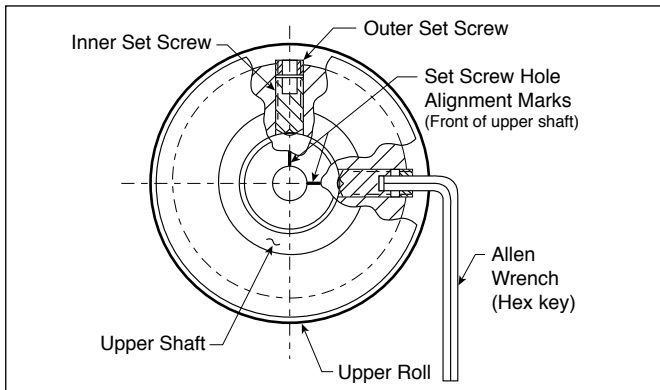

FIGURE 2

- Insert the allen wrench completely through the outer set screw and into each inner set screw, as shown in Figure 2 above. Loosen each inner set screw two turns.
- Repeat steps 14 – 15 on the remaining set screws that are 90° from the ones that were loosened previously.



- With one hand, support the upper roll from underneath. With the other hand, withdraw the upper shaft from the slide, as shown above. When the upper shaft is withdrawn, the upper roll will drop into your hand. Remove the upper roll from the right side of the tool.

REMOVAL OF THE EXISTING SLIDE

- Turn on the main power supply to the tool (main breaker panel, knife switch, etc.).



- Turn the power switch on the side of the tool to the "ON" position.

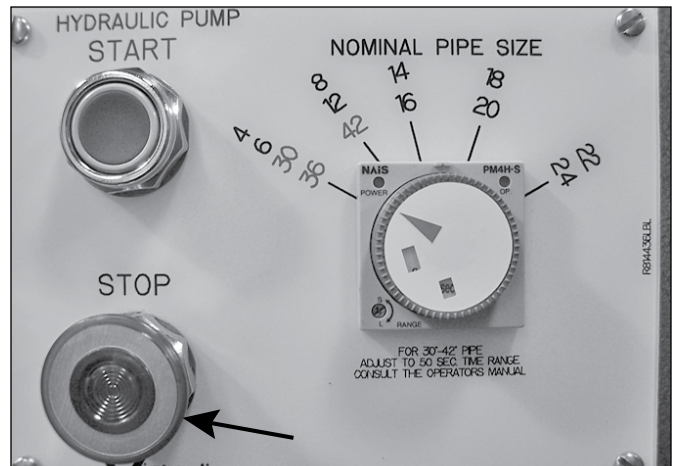

- Pull the red "STOP" knob to the out position.

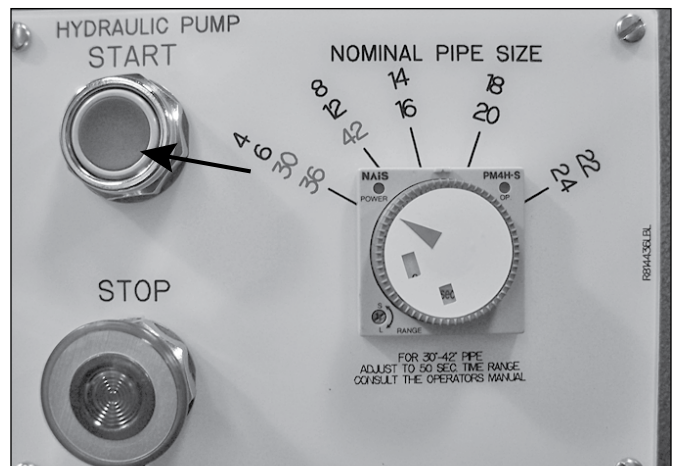

- Push the "HYDRAULIC PUMP START" button.

VE436MC Roll Grooving Tool

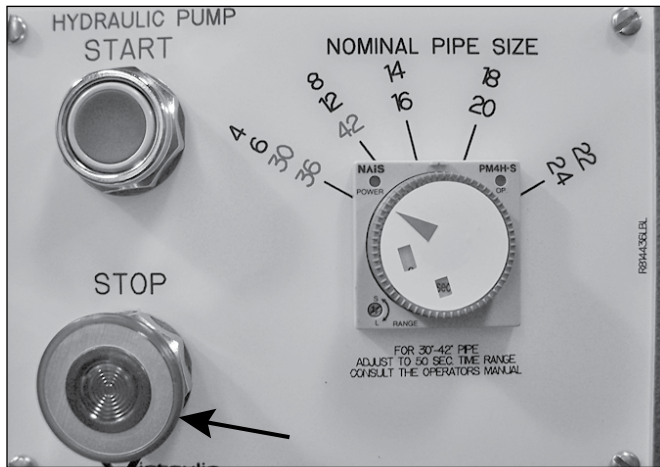

5. Depress the safety foot switch. When the slide moves to its lowest position, push down (in) on the red **"STOP"** knob. Release the safety foot switch, and withdraw your foot from the switch.



6. Turn the power switch on the side of the tool to the **"OFF"** position.

⚠ WARNING

- Always turn off the main power supply to the tool before making any tool adjustments.
- Failure to follow this instruction could result in death or serious personal injury.



7. Turn off the main power supply to the tool (main breaker panel, knife switch, etc.). Lock the switch in the **"OFF"** position to prevent accidental engagement. **NOTE:** Victaulic does not supply this lockout mechanism.

VE436MC Roll Grooving Tool

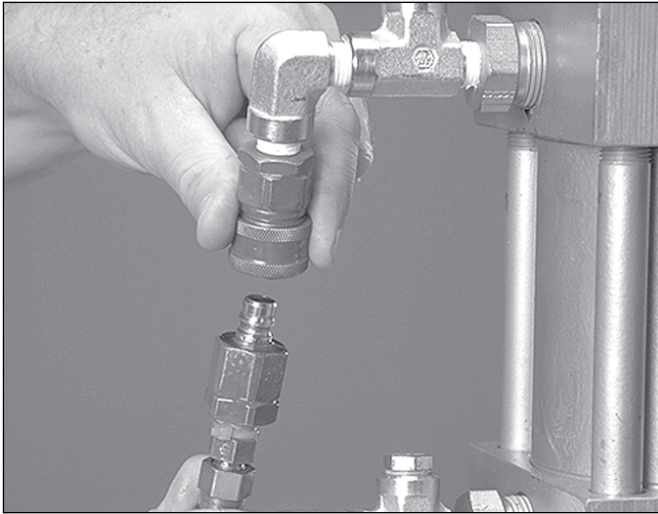

8. Disconnect the hydraulic hoses at the rear of the cylinder. Plug or cap the end of the hose and cylinder ports to prevent loss of hydraulic fluid. If the tool is equipped with quick connectors, it is not necessary to cap the ends. **NOTE:** Mark or tag the hoses as "top" or "bottom" accordingly to ensure each connection is made correctly in later steps.

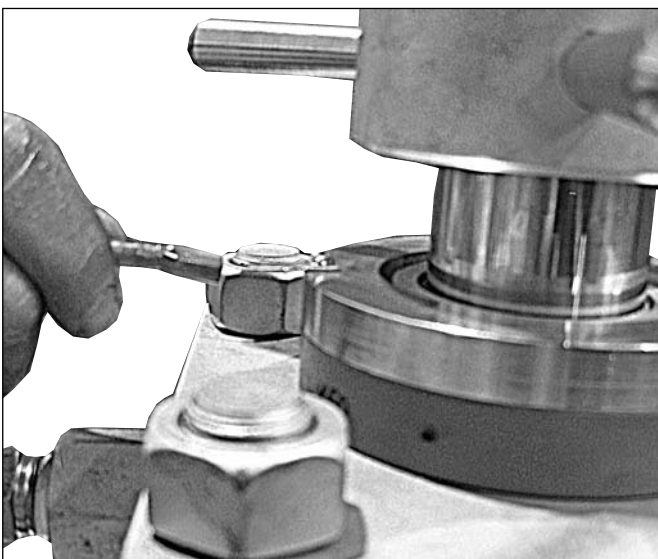
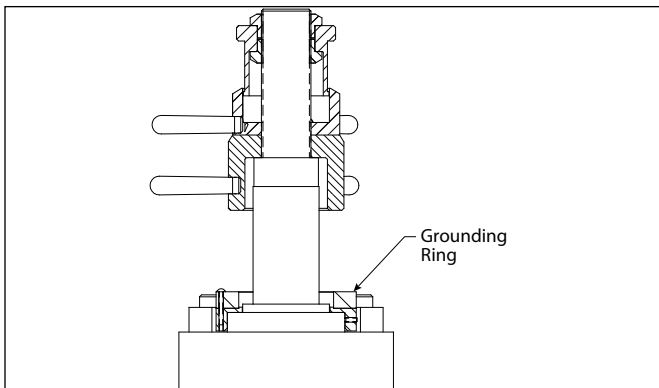

9. Disconnect the wire from the grounding ring, as shown above.

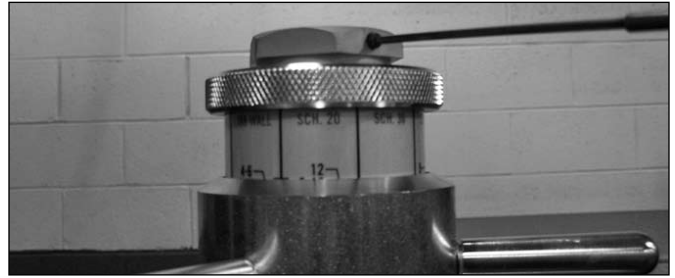

10. Using a $\frac{3}{32}$ -inch hex key wrench (not supplied), carefully loosen the set screw located above the depth adjuster barrel.



11. Unscrew the top calibration nut. Save this calibration nut for re-installation.



12. Remove the depth adjuster barrel by lifting it up and out of the depth adjuster. **DO NOT REMOVE THE BOTTOM CALIBRATION NUT.**



13. Remove and discard the original pipe size indicator label from the depth adjuster barrel. Clean the barrel with solvent to remove excess adhesive, oil, grease, etc. Allow the depth adjuster barrel to dry completely before proceeding with the next step.

VE436MC Roll Grooving Tool

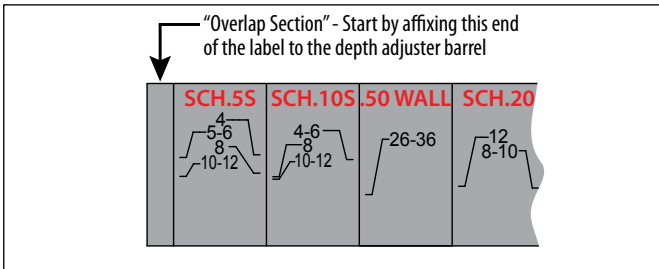
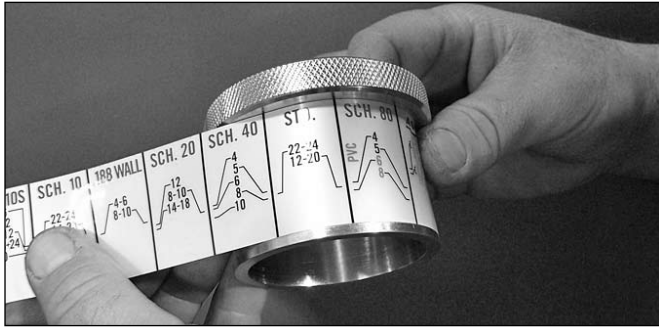

14. Remove part of the backing from the new pipe size indicator label (part number R129448LBL provided with the kit), starting with the side that contains the blank “overlap” section. Start the new label on the depth adjuster barrel with the side that contains the blank “overlap” section. Make sure the label stays flush with the bottom edge of the depth adjuster barrel’s extended portion, as shown above. Remove the remainder of the backing from the pipe size indicator label, and finish wrapping the label around the depth adjuster barrel. Press the label firmly against the depth adjuster barrel to force out any air pockets.

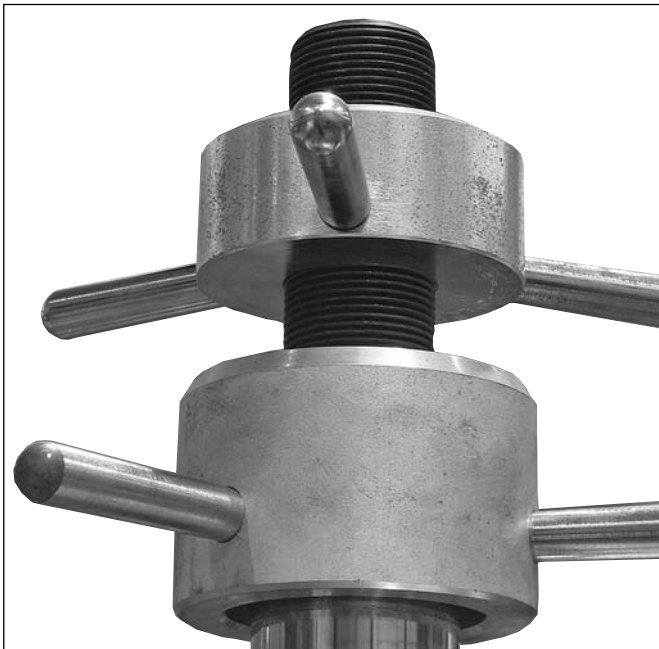

15. Move the depth adjuster up to allow space between it and the depth adjuster lock.

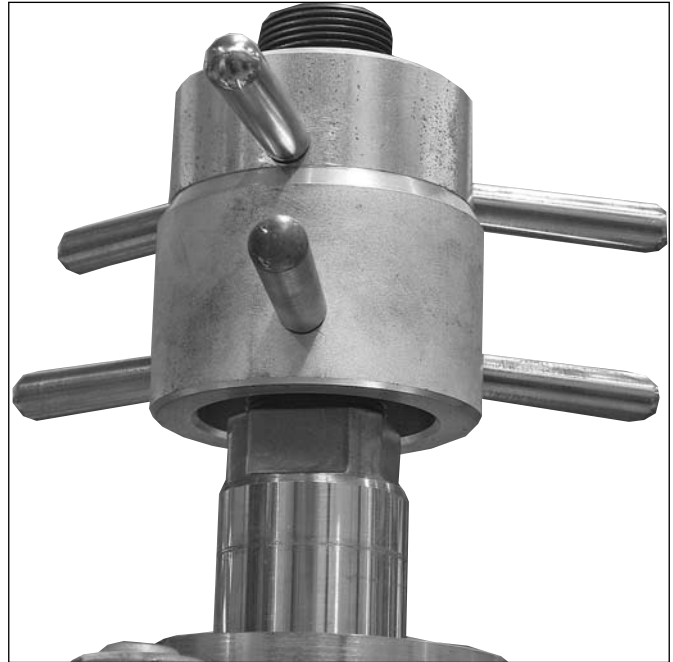

16. Move the depth adjuster lock up against the depth adjuster until the flats of the threaded rod are exposed, as shown above.



17. Loosen the set screw on the front of the slide five to six full turns.

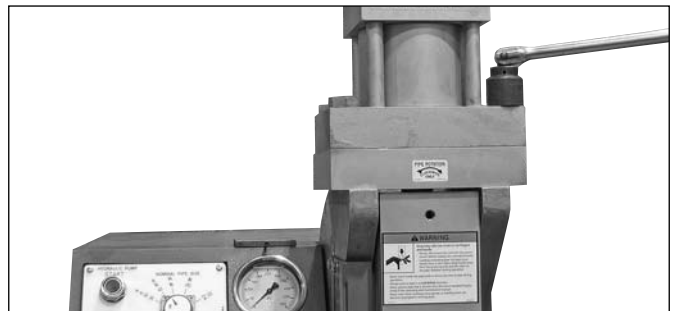

18. Remove the four hex bolts that attach the cylinder assembly to the cylinder mounting block.

VE436MC Roll Grooving Tool



19. With an adjustable wrench engaged on the flats at the top of the threaded rod (underneath the depth adjuster lock), rotate the cylinder assembly counterclockwise until it is free from the cylinder mounting block.



21. Remove the eight socket head cap screws located on top of the cylinder mounting block.

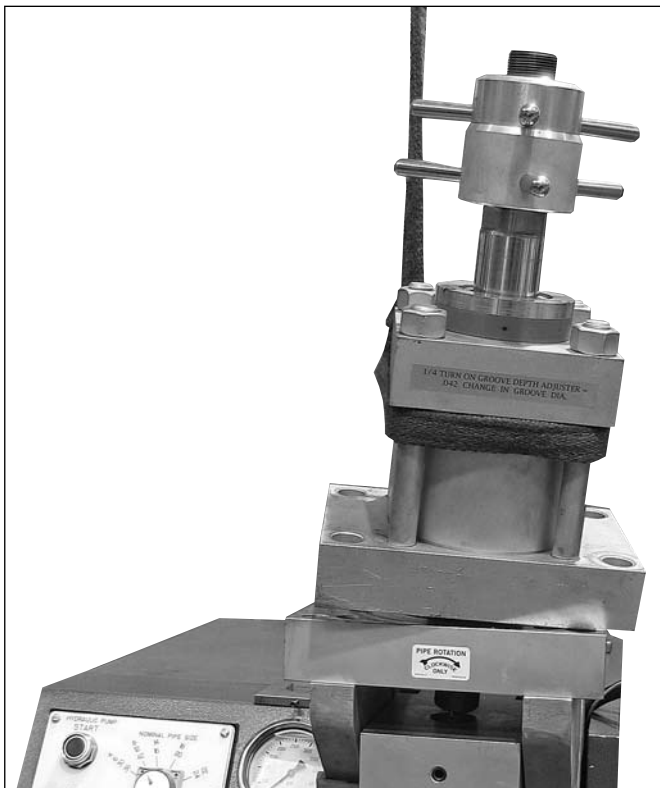

20. Remove the cylinder assembly from the cylinder mounting block.
NOTE: The cylinder and threaded rod are heavy. A crane, or other lifting equipment, should be used to remove the cylinder assembly.



22. Place a mark on the cylinder mounting block to identify which side is the front. Remove the cylinder mounting block.

VE436MC Roll Grooving Tool



23. Remove the plate from the back side of the slide, as shown above.

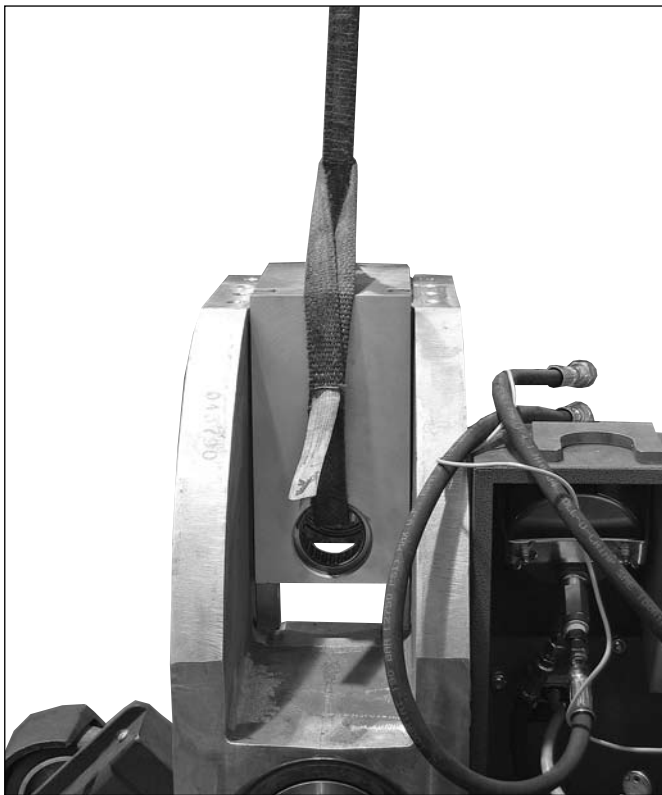

24. Lift the existing slide off the gibs. **NOTE:** The slide is heavy. A crane, or other lifting equipment, should be used to remove the slide.

INSTALLATION OF THE NEW SLIDE

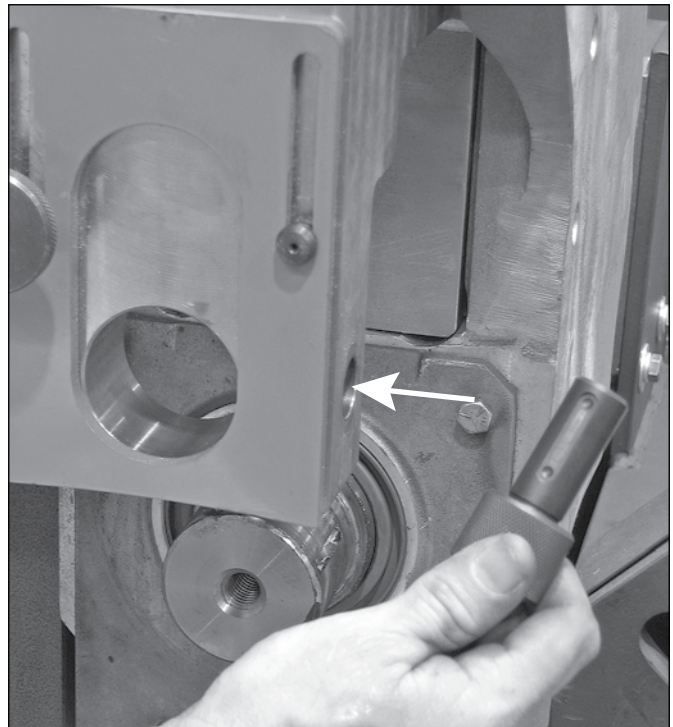

1. Place the new slide onto the gibs.
- 1a. Install the upper shaft pin into the slide (with the detents facing down) at the location shown above. **NOTE:** The ball plunger, located in the hole at the bottom of the slide, may need to be loosened in order to insert the upper shaft pin. Re-adjust the ball plunger to allow the upper shaft pin to slide from left to right without coming out of the slide.

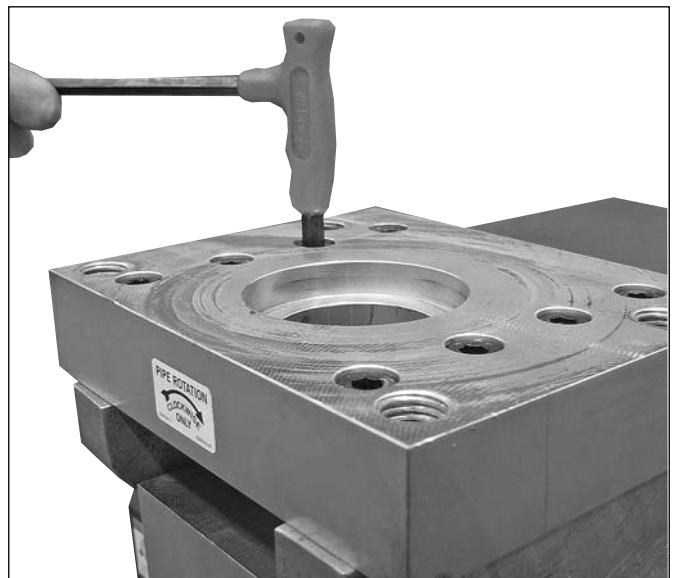

2. Re-install the cylinder mounting block, with the mark made in the previous section, facing toward the front of the tool.
- 2a. Tighten the eight socket head cap screws on top of the cylinder mounting block securely.

VE436MC Roll Grooving Tool



3. Re-install the cylinder assembly onto the cylinder mounting block.
NOTE: The cylinder and threaded rod are heavy. A crane, or other lifting equipment, should be used to install the cylinder assembly.



4. With an adjustable wrench engaged on the flats at the top of the threaded rod (underneath the depth adjuster lock), re-install the cylinder assembly by rotating it clockwise. As the cylinder assembly is rotated/tightened, the gap between the slide and the cylinder mounting block will be reduced, as shown above. Make sure the hydraulic connections face the back of the tool when the tightening process is complete.

VE436MC Roll Grooving Tool

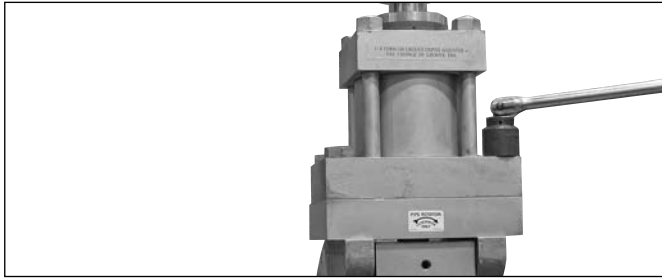

5. Insert the four hex bolts through the cylinder assembly and into the cylinder mounting block. Tighten the four hex bolts completely.



6. Tighten the set screw on the front of the new slide. **DO NOT** over-tighten the set screw, since damage to the cylinder threads may occur.

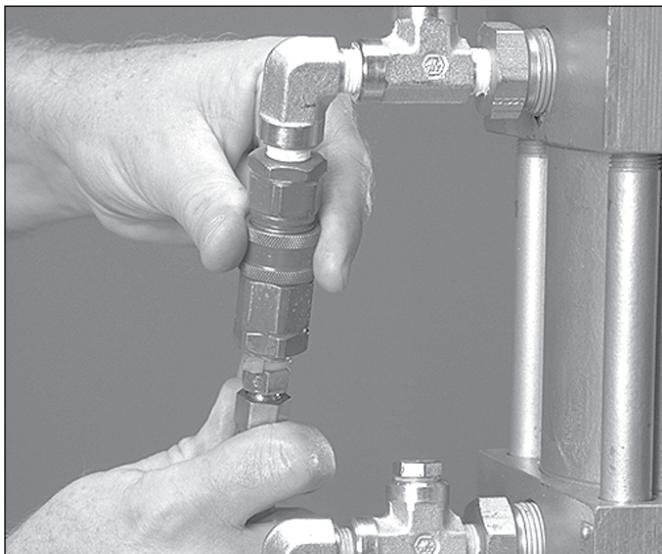

7. Re-connect the hydraulic lines to the back of the hydraulic cylinder. **NOTE:** Refer to the marks made in the previous section to ensure the correct hose is connected at the proper location.

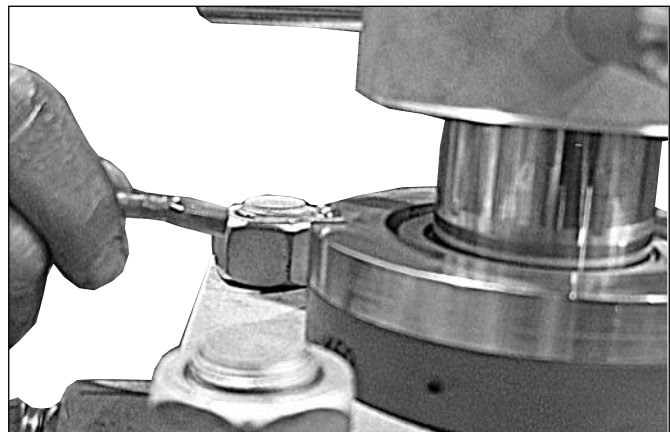
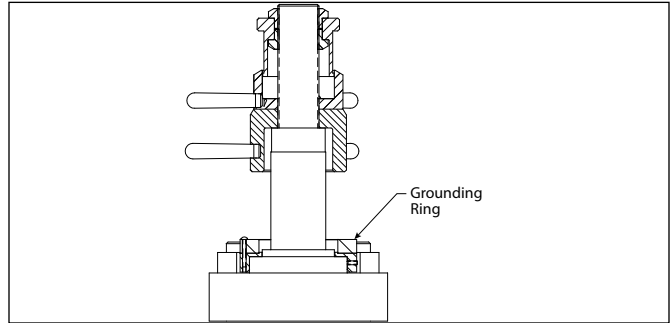

8. Re-connect the wire to the grounding ring at the top of the cylinder.



9. Lower the depth adjuster lock and depth adjuster to allow for re-installation of the depth adjuster barrel. Re-install the depth adjuster barrel into the depth adjuster.



10. Re-install the top calibration nut. **DO NOT** tighten the top calibration nut completely. The depth adjuster barrel should be able to rotate easily. If the depth adjuster barrel cannot be rotated easily, turn the top calibration nut counterclockwise until the depth adjuster barrel rotates freely.

VE436MC Roll Grooving Tool



11. Tighten the set screw for the top calibration nut. **DO NOT** over-tighten the set screw, since damage to the ram shaft threads may occur.

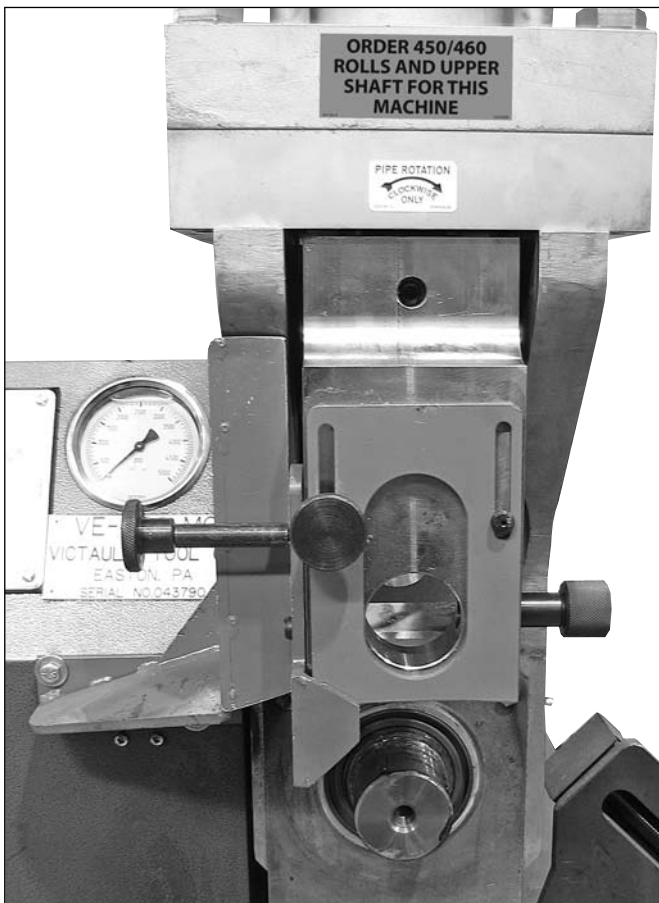

12. Affix the orange label, provided in the kit, at the location shown above. This label identifies the machine as having the upgraded slide kit.

REMOVAL OF THE EXISTING GUARD ASSEMBLY

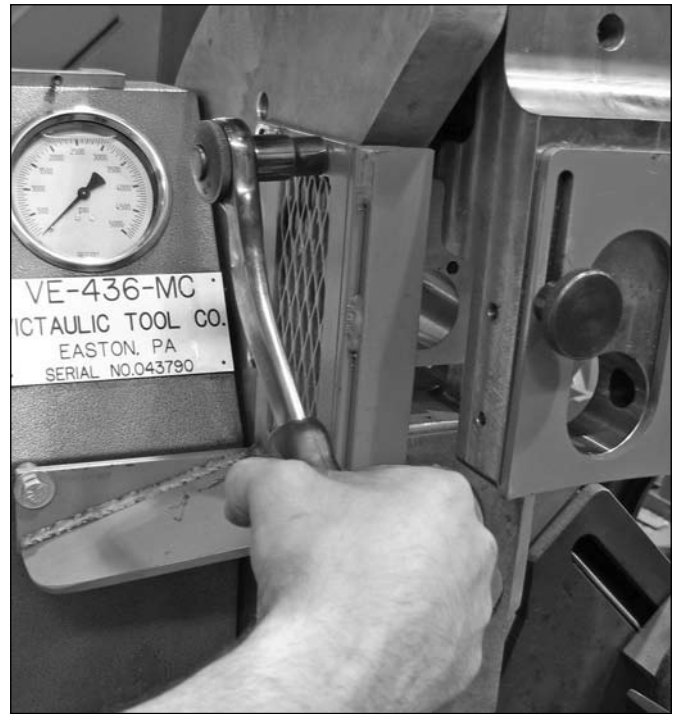

1. Remove the three sets of bolts/washers from the existing guard assembly. Keep the bolts/washers for installation of the new guard assembly in the next section.
2. Remove the existing guard from the tool.

VE436MC Roll Grooving Tool

INSTALLATION OF THE NEW GUARD ASSEMBLY



1. Align the slots in the new roll guard with the holes in the side of the tool where the old guard was removed in the previous section.
2. Install the three sets of bolts with washers, that were removed in the previous section, through the three slot locations in the new roll guard and into the holes in the tool, as shown above. Tighten the bolts completely.



3. Install the sliding guard between the roll guard and slide, as shown above. Install the knob with standoff through the slot in the sliding guard and into the upper hole in the slide, as shown above. Thread the knob standoff completely into the hole in the slide.

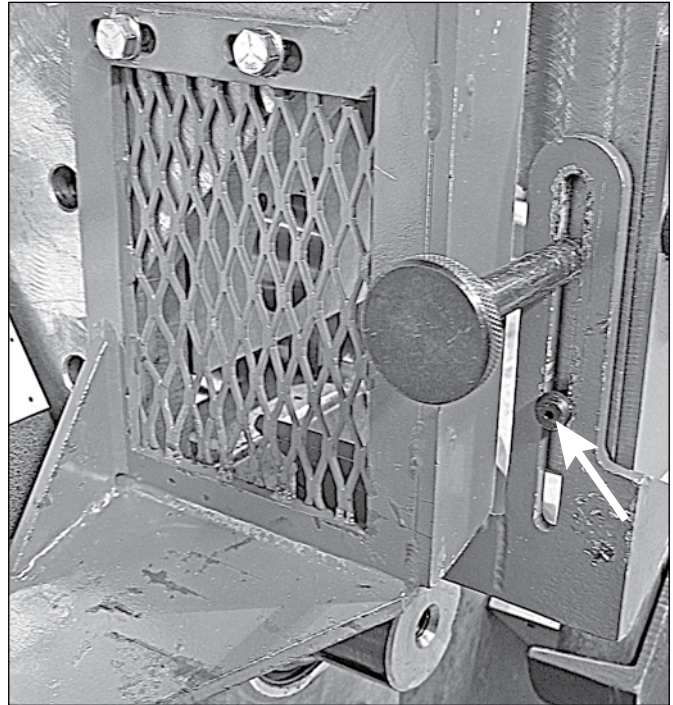

4. Install the guard retaining stud through the slot in the sliding guard and into the lower hole in the slide, as shown above. Tap the guard retaining stud completely into the hole in the slide to retain the sliding guard.

VE436MC Roll Grooving Tool

AIR BLEEDING

This section must be completed to remove any air that may have entered the hydraulic system during slide changeout.

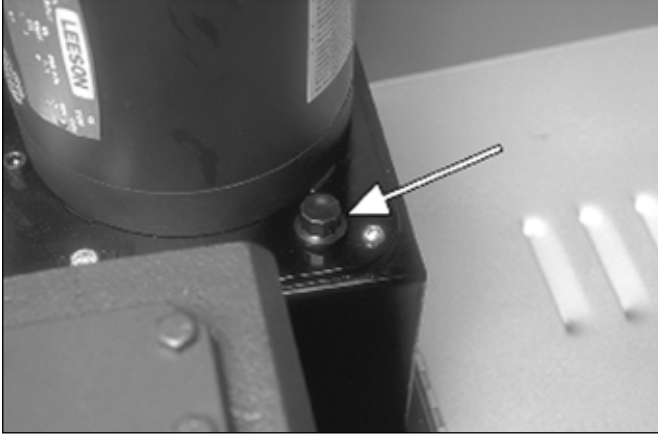

1. Remove the fill/vent plug from the hydraulic tank.

RECOMMENDED HYDRAULIC OIL

(High-Pressure, Anti-Wear/Anti-Foam Hydraulic Oil ISO Grade 32)

Manufacturer	Product
BP Amoco	Energol HLP-HM32
Gulf Oil Corp.	Harmony 32 AW
Kendall Refining Co.	Kenoil R&O AW-32
Lubriplate	HO-o
Mobil Oil Corp.	Mobil DTE 24
Pennzoil Products Co.	Pennzbell AW32
Shell Oil Co.	Tellus 32
Sun Refining	Survis 832
Texaco Inc.	Rando

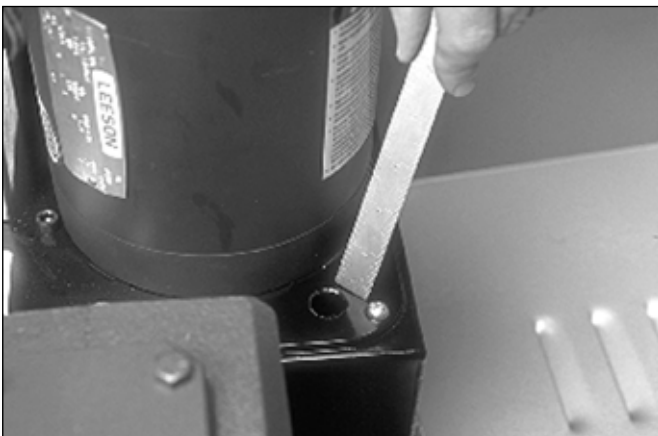

2. Bring the hydraulic oil level up to 1 – 2 inches/25 – 50 mm from the top of the tank. Refer to the “Recommended Hydraulic Oil” table above for the proper hydraulic oil.

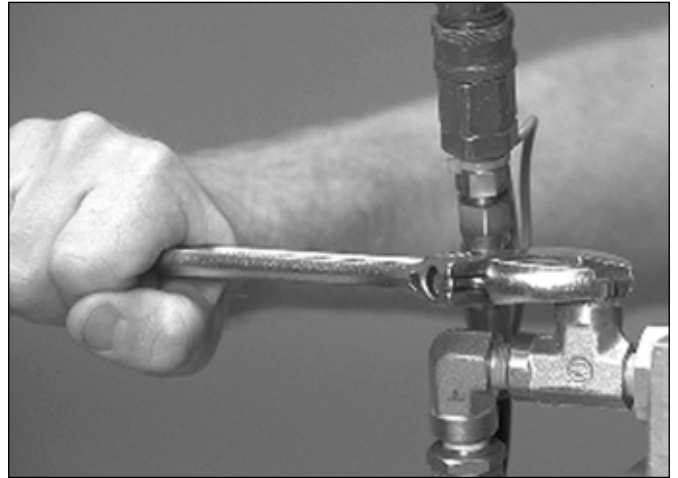

3. Remove the plug from the tee at the bottom of the hydraulic cylinder port.

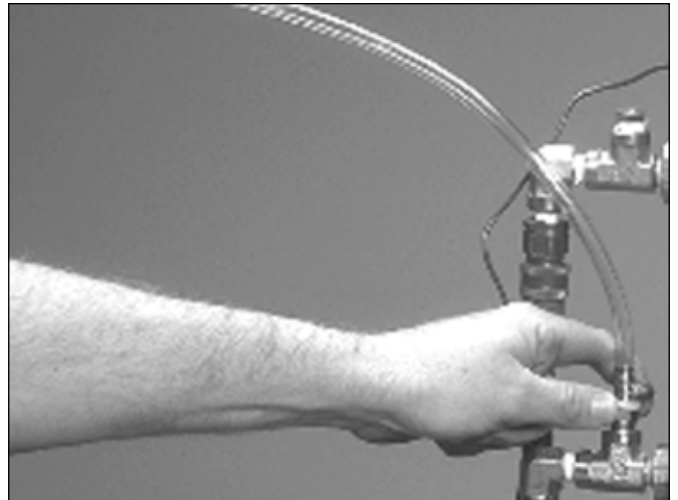

4. Install the bleeder tube into the tee, as shown above. Insert the other end of the bleeder tube into the fill/vent hole in the hydraulic tank. **NOTE:** The bleeder tube consists of a ¼-inch NPT barb hose fitting and 4 feet/1.2 m of ¼-inch ID clear vinyl hose (supplied with the tool).
5. Turn on the main power supply to the tool (main breaker panel, knife switch, etc.).

VE436MC Roll Grooving Tool



6. Turn the power switch on the side of the tool to the "ON" position.

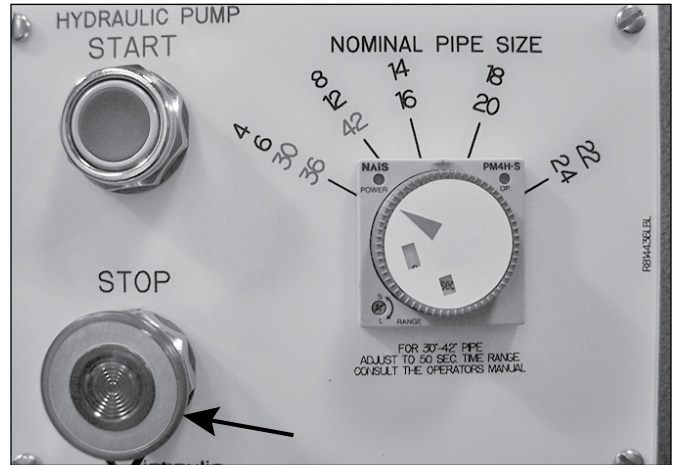

10. Push down (in) on the red "STOP" knob.

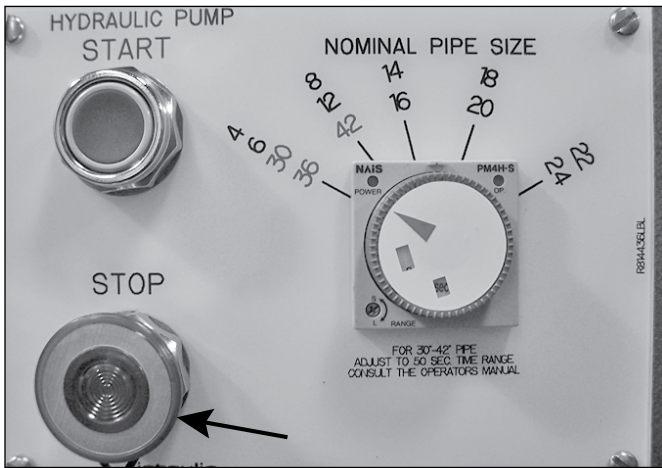

7. Pull the red "STOP" knob to the out position.

NOTICE

- To prevent oil from flowing out of the tee while removing the bleeder tube and installing the plug, block the groove diameter stop from moving down by inserting a piece of wood between the groove diameter stop and the top of the hydraulic cylinder.
- To prevent air from entering the tee while the bleeder tube is removed and the plug in installed, hold the 4-way valve in the "shifted" position by pressing in on the rubber boot on the end of the valve. Keep the rubber boot depressed until the plug is installed and tightened.

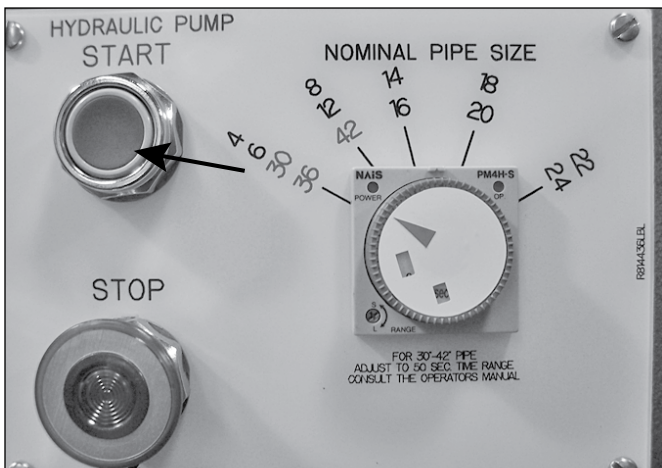

8. Push the "HYDRAULIC PUMP START" button. Hydraulic oil will start flowing from the tee through the bleeder tube and into the tank.
9. Depress the safety foot switch, hold it down for 5 seconds, then release it for 5 seconds. Repeat this step until no air bubbles can be seen through the clear vinyl tube.

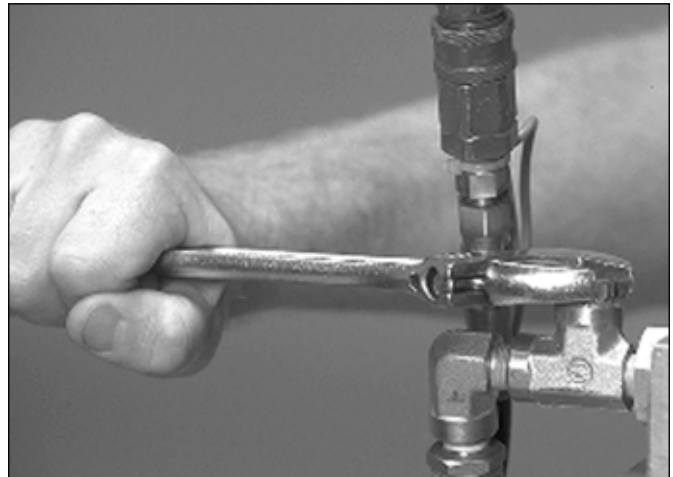

11. Remove the bleeder tube, and install the plug into the tee. **DO NOT ALLOW AIR TO GET BACK INTO THE TEE WHEN INSTALLING THE PLUG (REFER TO NOTICE ABOVE).**

VE436MC Roll Grooving Tool

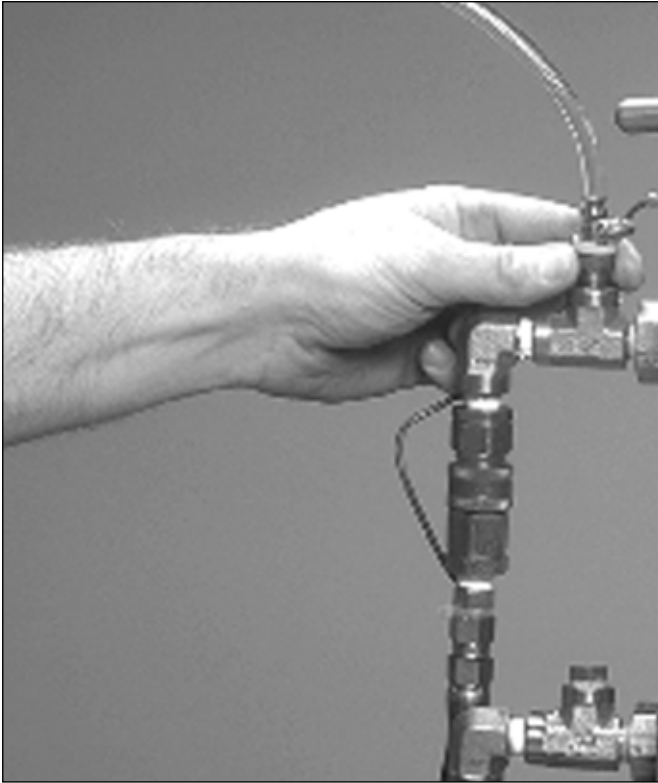

12. Repeat steps 4 – 11 for bleeding air from the tee at the top of the hydraulic cylinder port. Refer to the photo above for bleeder tube installation.

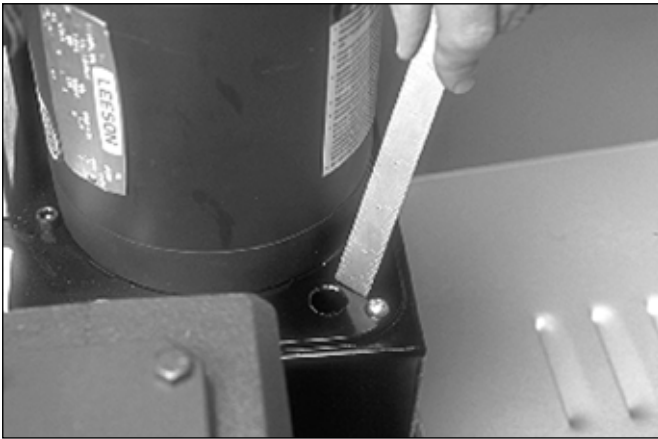

13. Bring the hydraulic oil level up to 1 – 2 inches/25 – 50 mm from the top of the tank. Refer to the “Recommended Hydraulic Oil” table for the proper hydraulic oil.

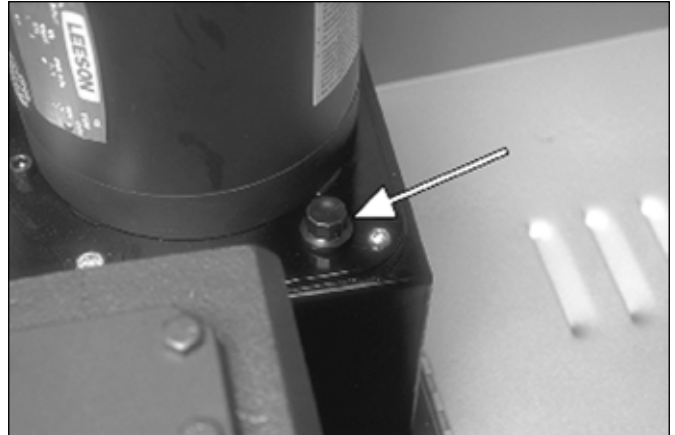

14. Re-install the fill/vent plug into the hydraulic tank.
15. Installation of the slide upgrade kit is now complete.

VE436MC Roll Grooving Tool

ADDITIONAL INFORMATION

- Series 450/460 Roll Set Installation
- Adjusting the Roll Guards
- Series 450/460 Roll Set Removal

NOTICE
<ul style="list-style-type: none">• If preparing the tool to groove 26-inch/660.0-mm and larger pipe: Refer to the “Tool Height Adjustment and Stabilizer Re-Location” section of the TM-VE424MC/VE436MC Operating and Maintenance Instructions manual.• Refer to the “Grooving Operation” section of the TM-VE424MC/VE436MC Operating and Maintenance Instructions manual to groove the pipe.

VE436MC Roll Grooving Tool

SERIES 450/460 ROLL SET INSTALLATION

1. Select the proper roll set by referring to the markings on the front face of the rolls. The rolls are color coded for the pipe material.
2. Prior to installation, clean the upper shaft and the upper roll (provided in the kit) to remove any foreign material. Inspect the bearing in the upper roll for proper lubrication and condition. If damage is present, replace any affected components.



3. Pull the upper shaft pin out of the slide until it stops.
4. Install the proper upper roll behind the slide, as shown above. Make sure the markings on the upper roll are facing forward. While supporting the upper roll, insert the upper shaft into the slide and upper roll. DO NOT force the upper shaft into the tool.

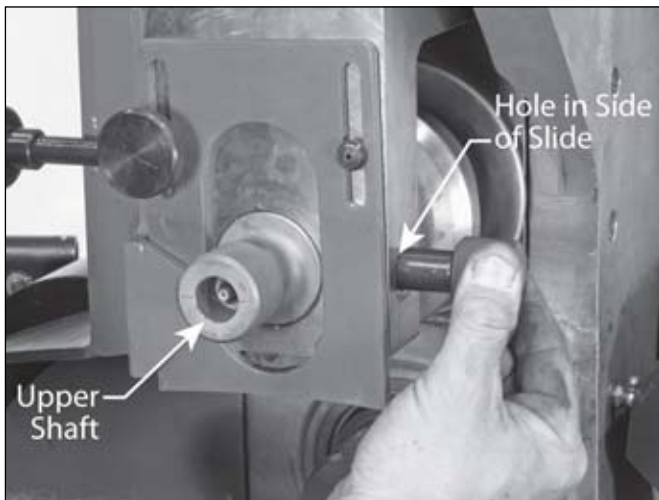

5. Align the hole in the upper shaft with the hole in the side of the slide. Push the upper shaft pin into the slide/upper shaft until it stops.

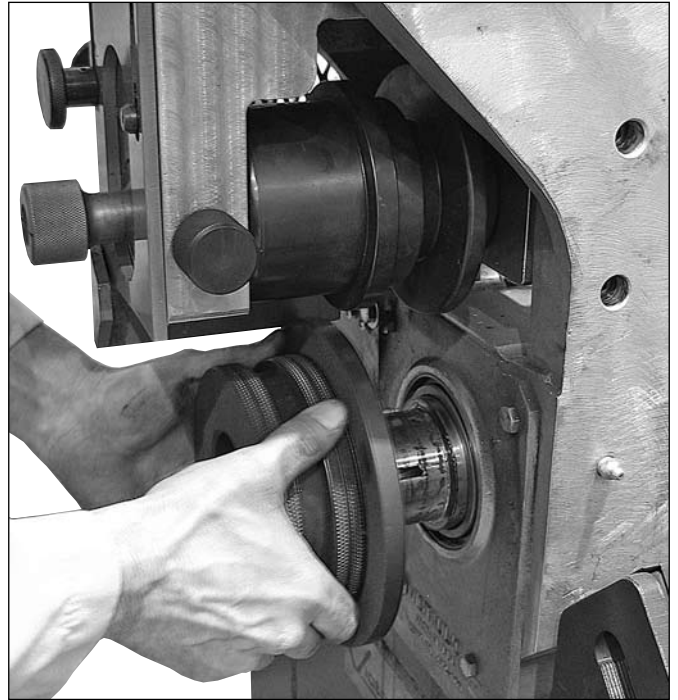

6. Clean the main shaft. Apply a thin film of grease or anti-seize lubricant to the surface of the main shaft where the lower roll seats. **NOTE:** A thin film of grease will permit lower roll removals the next time a roll change is made.
- 6a. Install the lower roll onto the main shaft, as shown above. Make sure the lower roll fits over the Woodruff key.

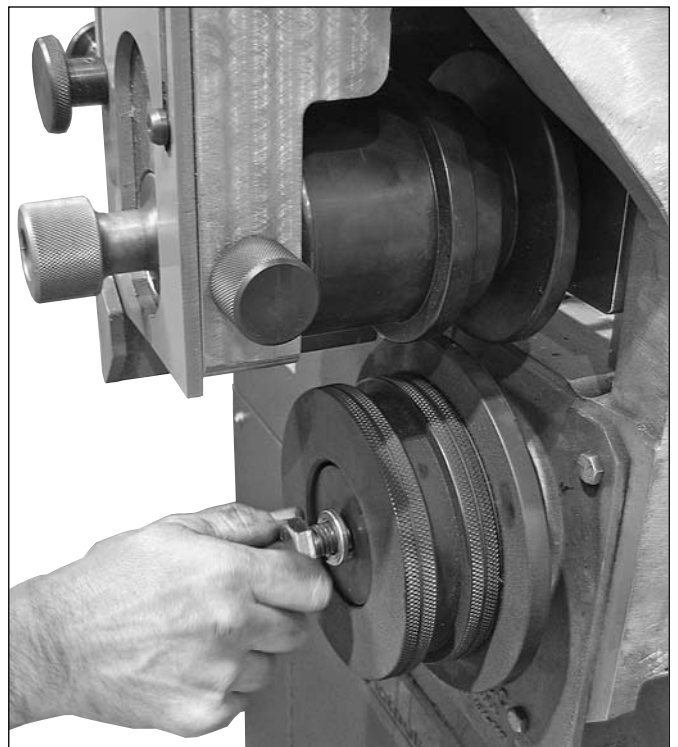

7. Install the lower roll washer and $\frac{5}{8}$ -inch bolt.

VE436MC Roll Grooving Tool

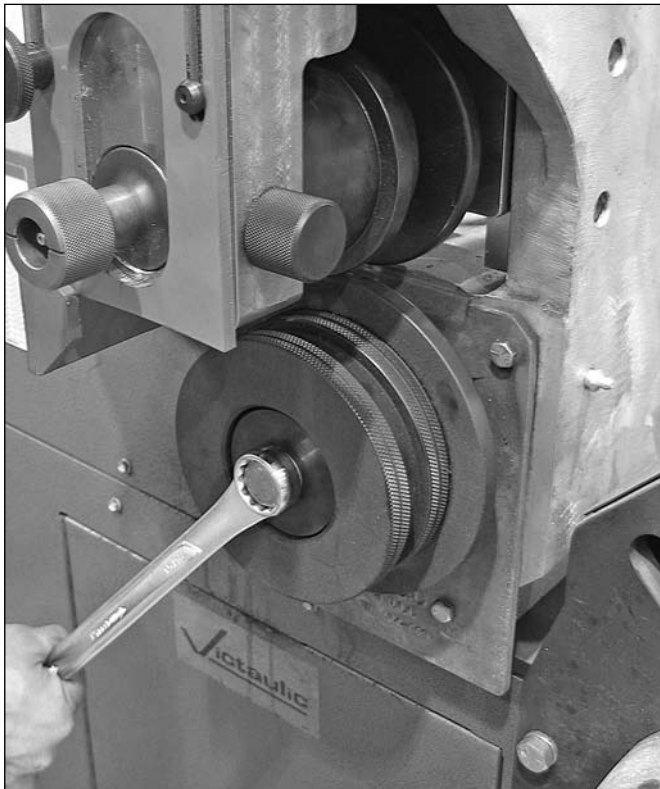

8. Using a 1 5/16-inch wrench, tighten the bolt securely.
9. Turn on the main power supply to the tool (main breaker panel, knife switch, etc.).



10. Turn the power switch on the side of the tool to the "ON" position.

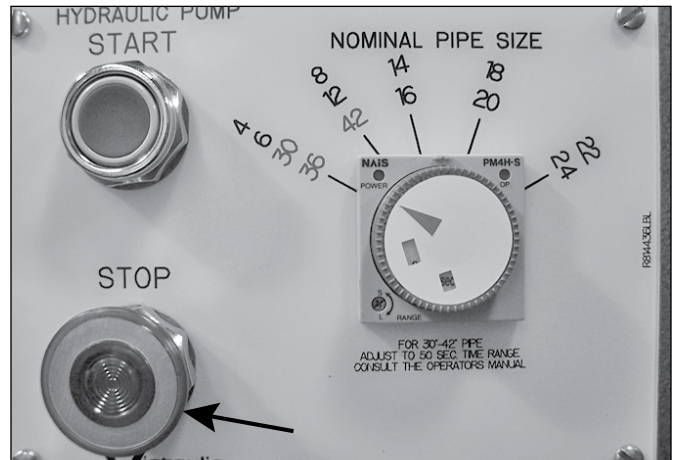

11. Pull the red "STOP" knob to the out position.

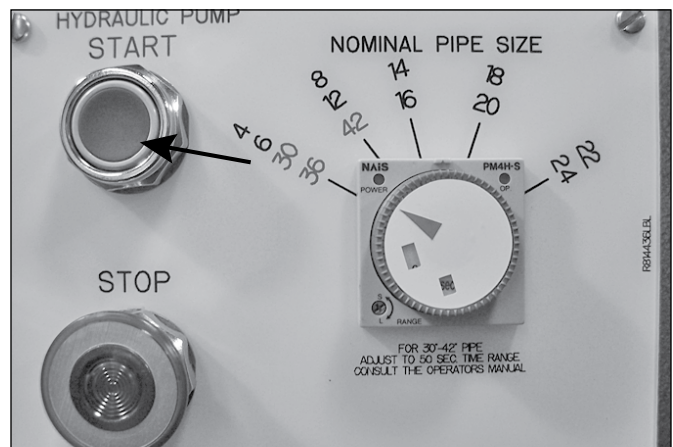

12. Push the "HYDRAULIC PUMP START" button.

⚠ WARNING

Grooving rolls can crush or cut fingers and hands.

- Keep hands away from the grooving rolls and the roller on the pipe stabilizer during operation.

13. Depress the safety foot switch. As the slide advances, align the upper roll's "groove" with the lower roll's backstop flange. Align the upper roll by pushing or pulling on the knob on the front of the upper shaft.

VE436MC Roll Grooving Tool

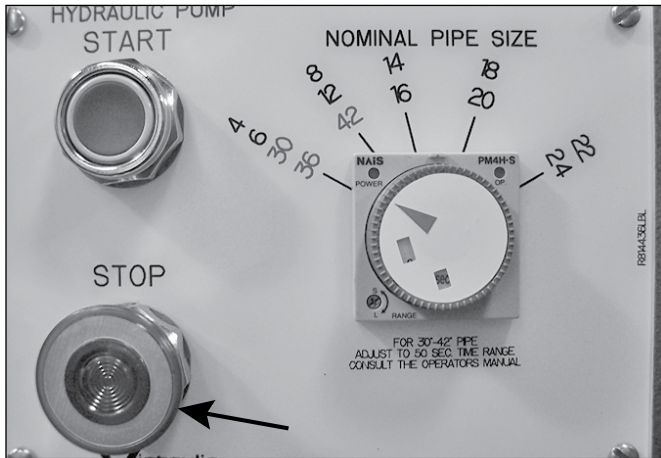

14. After the slide has advanced approximately 1 inch/25 mm, and the rolls are aligned and engaged, push down (in) on the red **"STOP"** knob. Release the safety foot switch, and withdraw your foot from the switch.
15. Snap the new slide spacer (included with the kit) into the tool between the top of the slide and the bottom of the cylinder mounting block.

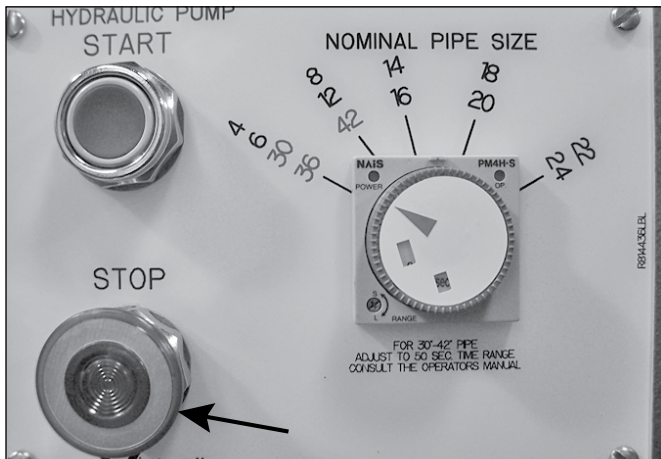

16. Pull the red **"STOP"** knob to the out position.

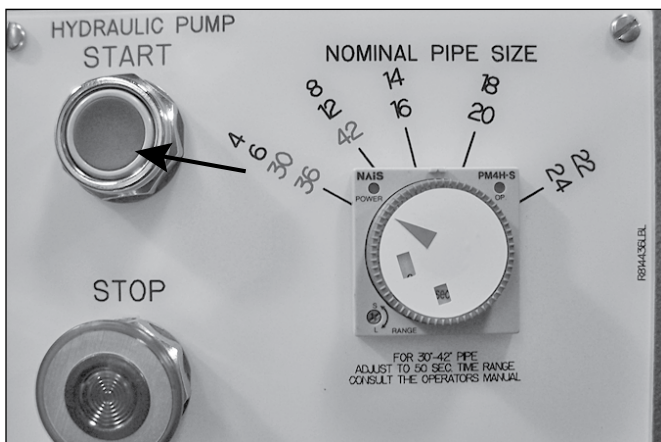

17. Push the **"HYDRAULIC PUMP START"** button to retract (raise) the slide completely.

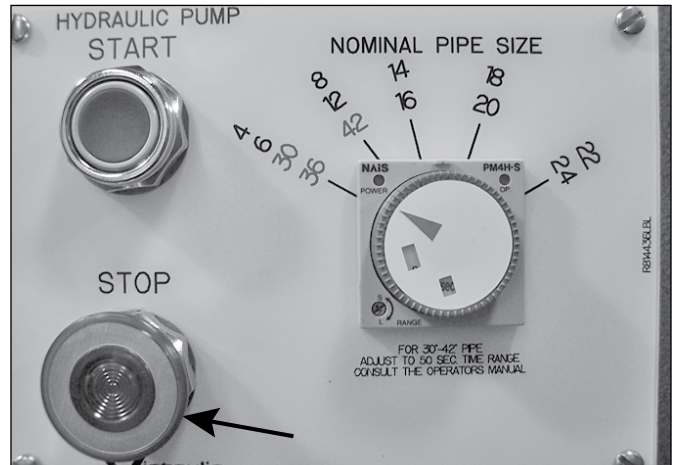

18. After the slide has been retracted (raised) completely, push down (in) on the red **"STOP"** knob.

RECOMMENDED GENERAL PURPOSE EP LITHIUM-BASE GREASE

Manufacturer	Product
BP Amoco	Energrease LC-EP2
Gulf Oil Corp.	Gulfcrown Grease EP#2
Lubriplate	No. 630-2
Mobil Oil Corp.	Mobilux EP2
Pennzoil Products Co.	Pennlith EP 712 Lube
Shell Oil Co.	Alvania EP2
Sun Refining	Sun Prestige 742 EP
Texaco Inc.	Multifak EP2

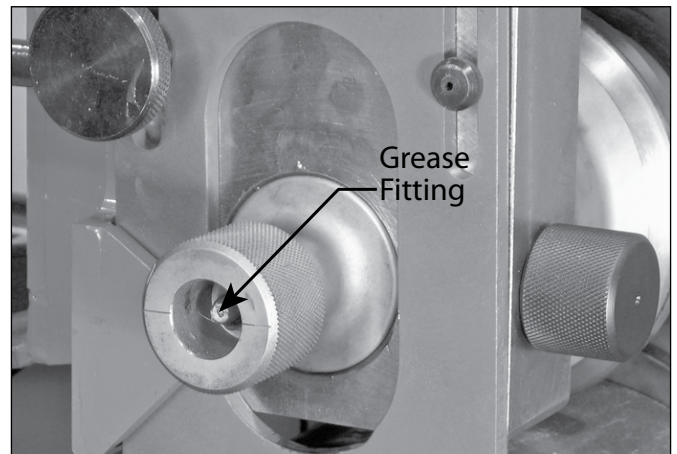

19. Lubricate the upper roll bearings every time rolls are changed and after every 8 hours of operation. A grease fitting is provided on the front of the upper shaft, as shown above. Refer to the table above for recommendations.

VE436MC Roll Grooving Tool

ADJUSTING THE ROLL GUARDS

Guards must be adjusted every time the rolls are changed or when the pipe size or wall thickness is different from the previous pipe that was grooved.



1. Turn the power switch on the side of the tool to the "OFF" position.

WARNING

- Always turn off the main power supply to the tool before making any tool adjustments.

Failure to follow this instruction could result in death or serious personal injury.

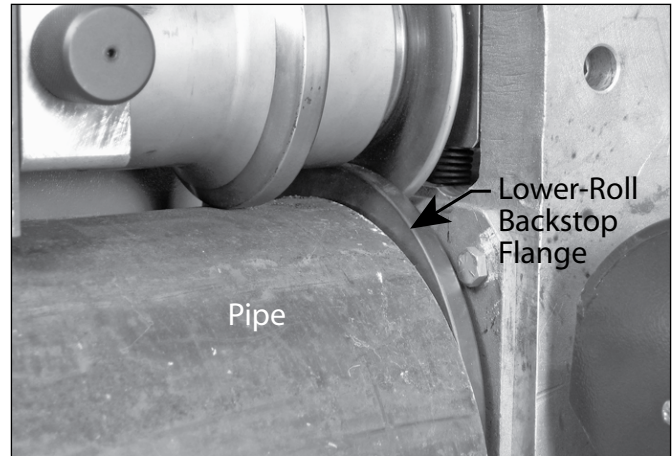

3. Insert a length of pipe that is the correct size and schedule onto the lower roll. Make sure the pipe end contacts the lower-roll backstop flange. The pipe must rest directly on top of the roll and must not be skewed to one side or the other. **NOTE:** If necessary, retract the pipe stabilizer to provide clearance for inserting the pipe over the lower roll. To retract the pipe stabilizer, loosen the locking handle, and use the handwheel to retract the roller.
4. Select the appropriate guard setting pad provided in the kit. **NOTE:** Two guard setting pads are included in the kit. One is specifically for pipe being grooved with original-type roll sets (¼-inch thick guard pad), and the other is specifically for pipe being grooved with AGS roll sets (⅜-inch thick guard pad containing a "FOR AGS ONLY" label).



2. Turn off the main power supply to the tool (main breaker panel, knife switch, etc.). Lock the switch in the "OFF" position to prevent accidental engagement. **NOTE:** Victaulic does not supply this lockout mechanism.

VE436MC Roll Grooving Tool

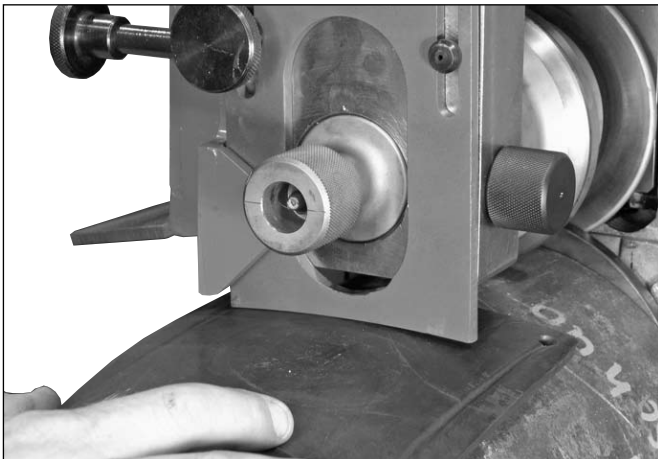
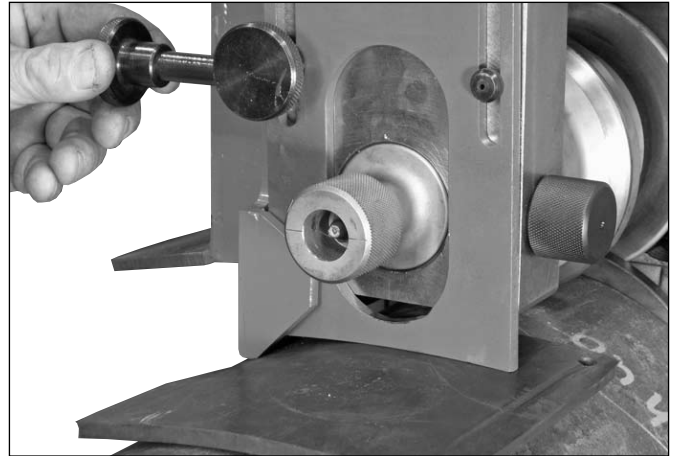
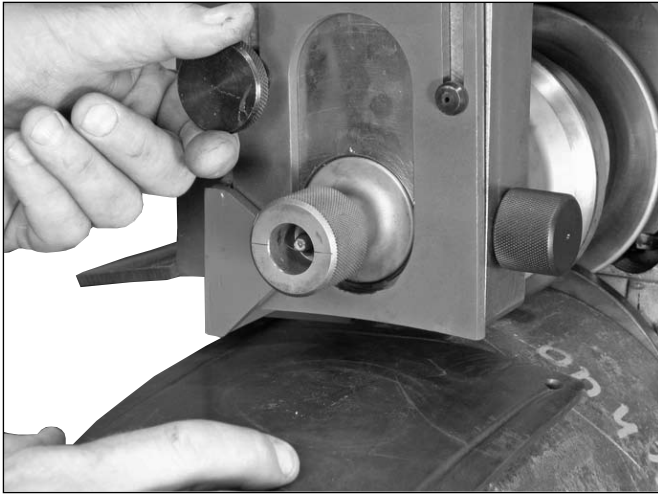

5. Hold the correct guard setting pad firmly against the pipe and push it under the roll guards. Loosen the knob on the front of the roll guards to drop the plate onto the guard setting pad. Tighten the knob.

6. Loosen the knob on the side of the roll guards to drop the sliding guard onto the guard setting pad. Tighten the knob.
7. Remove the guard setting pad from the pipe. Store the guard setting pad in the tool cabinet.

VE436MC Roll Grooving Tool

SERIES 450/460 ROLL SET REMOVAL

1. Turn on the main power supply to the tool (main breaker panel, knife switch, etc.).



2. Turn the power switch on the side of the tool to the "ON" position.

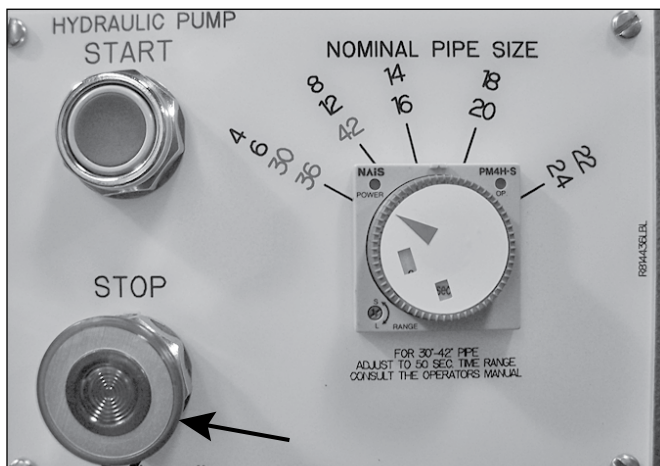

3. Pull the red "STOP" knob to the out position.

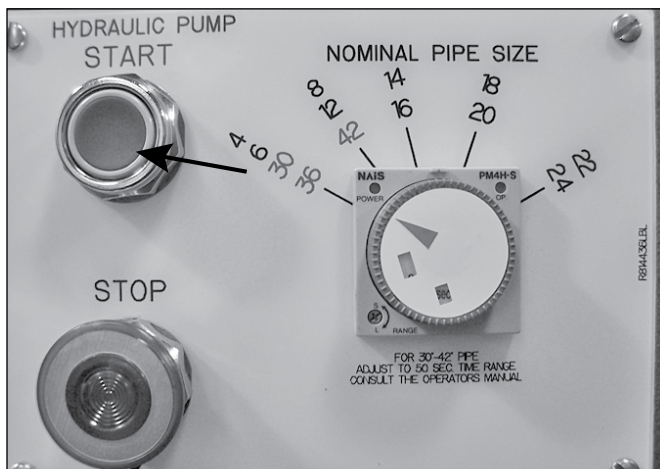

4. Push the "HYDRAULIC PUMP START" button.

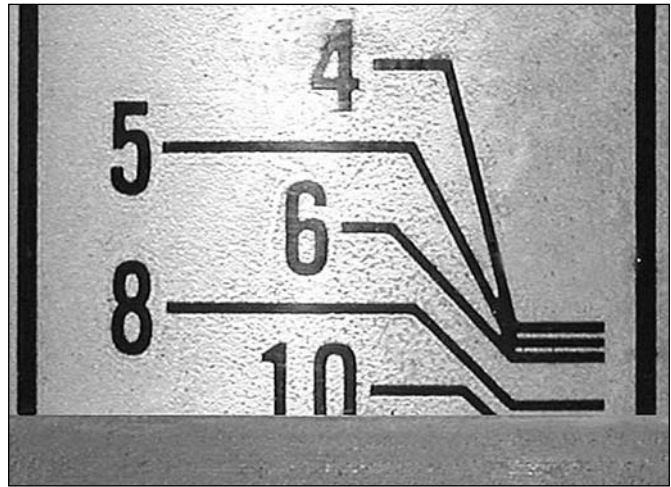

5. Rotate the depth adjuster to the setting for nominal size 8-inch Schedule 40 pipe, as shown above.

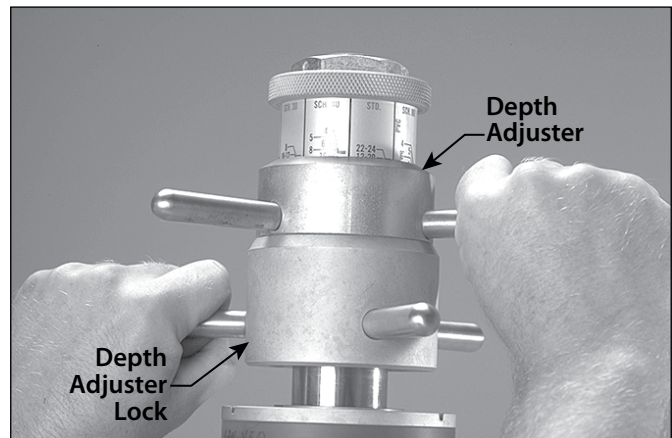

6. Hold the depth adjuster to prevent it from turning. Turn the depth adjuster lock clockwise to lock it with the depth adjuster.

VE436MC Roll Grooving Tool

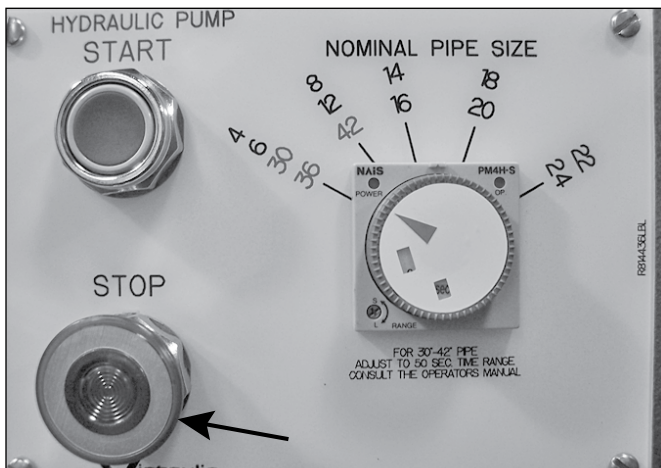
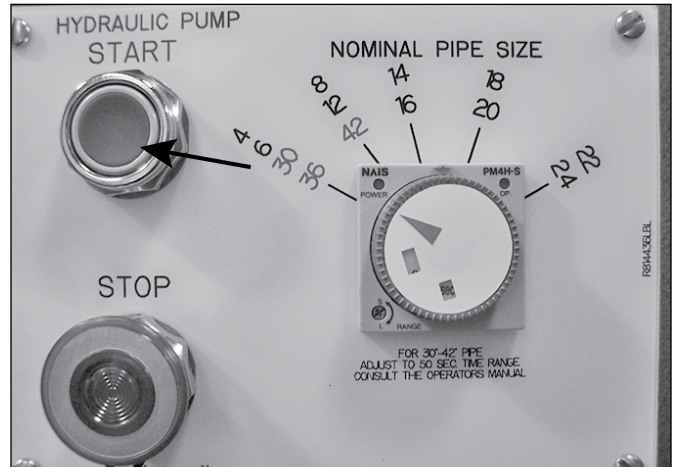
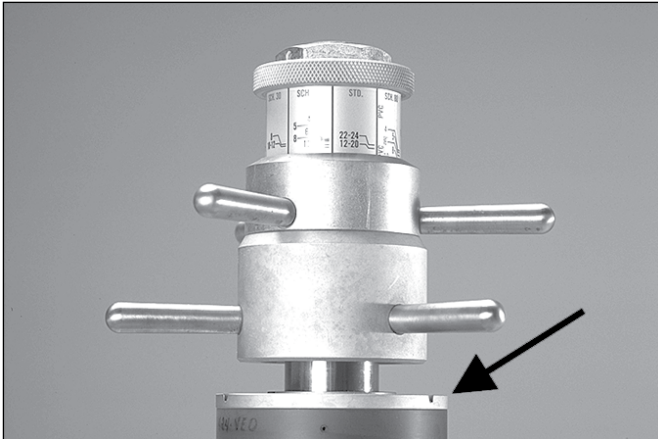

10. Push the **"HYDRAULIC PUMP START"** button to retract (raise) the slide.

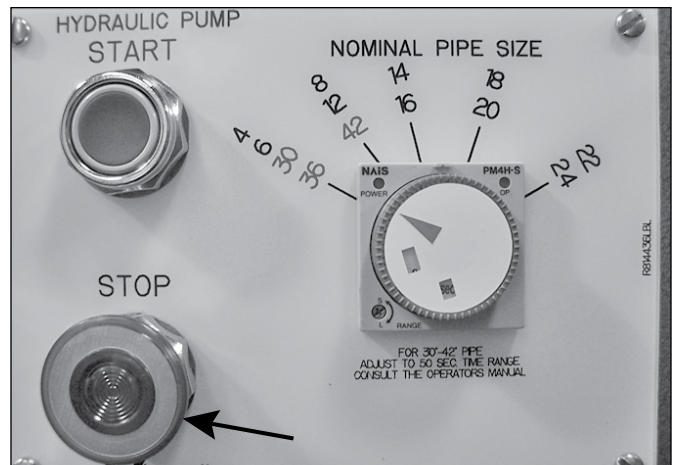

7. Depress the safety foot switch. When the groove diameter stop contacts the hydraulic cylinder, push down (in) on the red **"STOP"** knob. Release the safety foot switch, and withdraw foot from switch.
8. Remove the slide spacer by snapping it out directly.

11. After the slide is retracted (raised) completely, push down (in) on the red **"STOP"** knob.

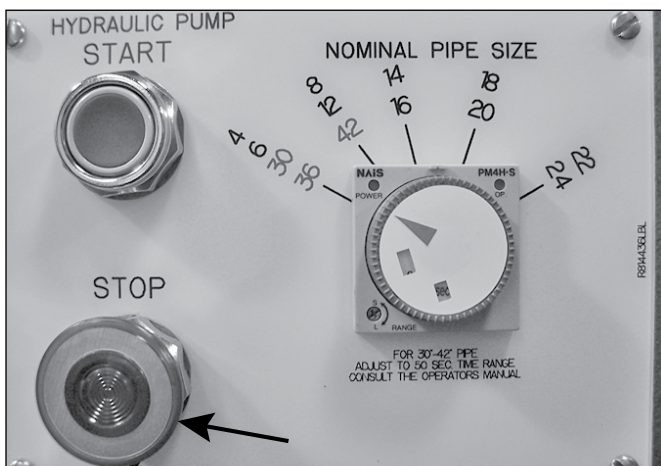

9. Pull the red **"STOP"** knob to the out position.



12. Turn the power switch on the side of the tool to the **"OFF"** position.

VE436MC Roll Grooving Tool

WARNING

- Always turn off the main power supply to the tool before making any tool adjustments.
- Failure to follow this instruction could result in death or serious personal injury.

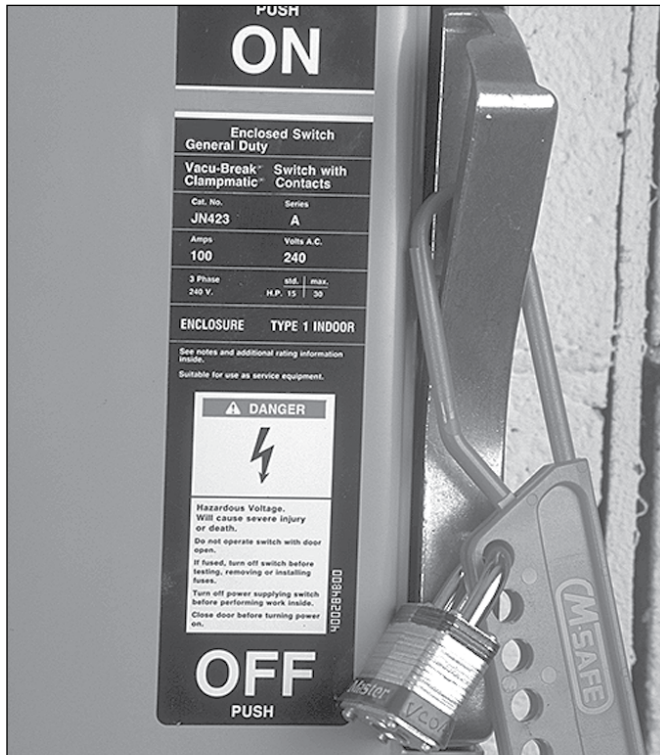

13. Turn off the main power supply to the tool (main breaker panel, knife switch, etc.). Lock the switch in the "OFF" position to prevent accidental engagement. **NOTE:** Victaulic does not supply this lockout mechanism.

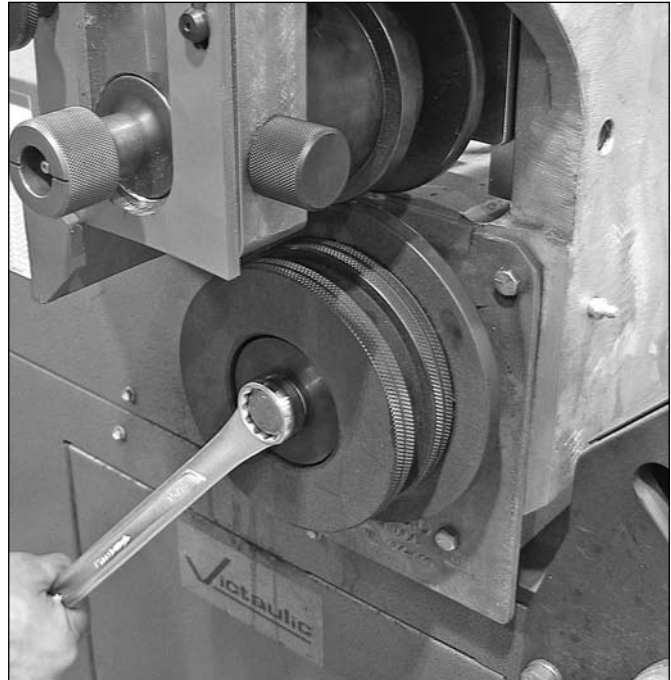

14. Using a $\frac{1}{16}$ -inch wrench, remove the $\frac{5}{8}$ -inch bolt and washer that secures the lower roll.

NOTICE

- Be careful not to lose the Woodruff Key. The Woodruff Key should remain in the lower shaft.
- If the Woodruff Key shows signs of damage, replace it with a new, Victaulic-supplied key.

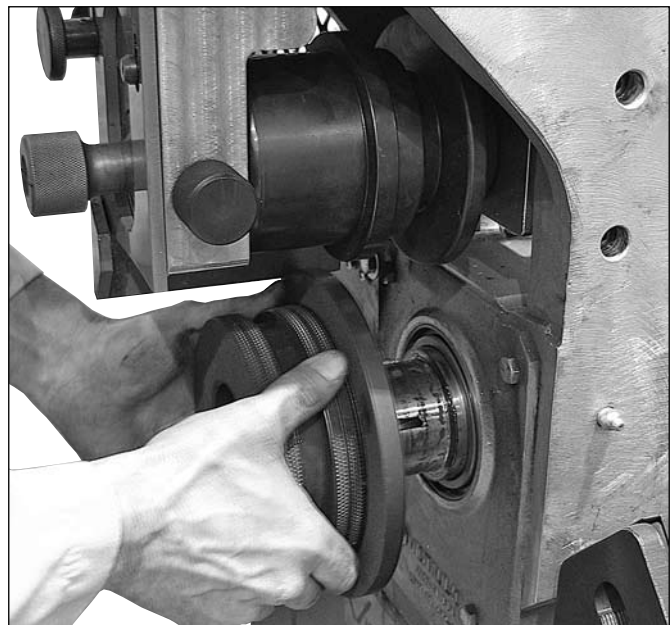

15. Pull the lower roll off the main shaft. Store the lower roll inside the tool cabinet. If the lower roll cannot be removed by hand, use a conventional gear puller. Be careful not to lose the Woodruff Key.

VE436MC Roll Grooving Tool

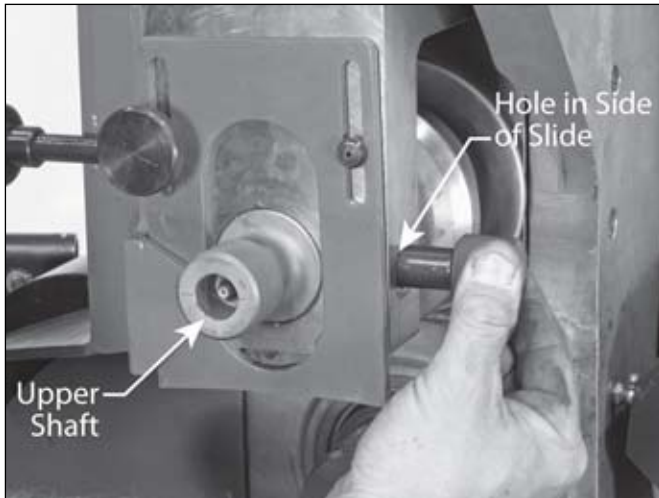

16. Pull the upper shaft pin out of the slide until it stops.



17. With one hand, support the upper roll from underneath. With the other hand, withdraw the upper shaft from the slide, as shown above. When the upper shaft is withdrawn, the upper roll will drop into your hand. Remove the upper roll from the right side of the tool.

VE436MC Roll Grooving Tool

For complete contact information, visit www.victaulic.com

TM-VE436MC.KIT 5573 REV A UPDATED 04/2009 RM00436KIT

VICTAULIC IS A REGISTERED TRADEMARK OF VICTAULIC COMPANY. © 2009 VICTAULIC COMPANY. ALL RIGHTS RESERVED. PRINTED IN THE USA.

TM-VE436MC.KIT

