

Victaulic Vortex™ Hybrid Fire Extinguishing System

For Protection of Wet Bench Applications and Similar Processing Equipment

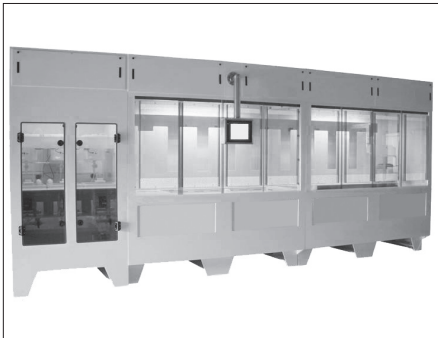

Automatic Wet Bench

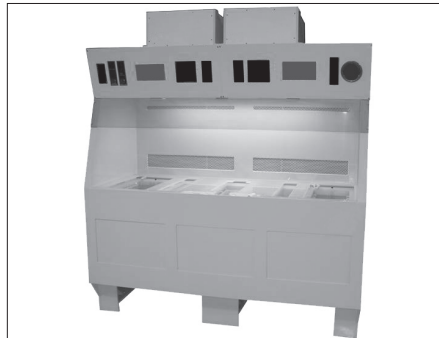

Manual Wet Bench



For Technical Questions,
Scan QR Code for Contact
Information for Your Region
victauliclocations.com

THIS GENERAL DESIGN MANUAL SHALL BE USED IN CONJUNCTION WITH THE I-VORTEX.IOM VICTAULIC VORTEX™ HYBRID FIRE EXTINGUISHING SYSTEM INSTALLATION, OPERATION, AND MAINTENANCE MANUAL.

⚠ WARNING



- Victaulic Vortex™ Hybrid Fire Extinguishing Systems shall be designed only by competent and certified system designers that have successfully completed all appropriate Victaulic training. System designs shall be conducted per all applicable laws, codes, and industry standards.
- System designers shall use sound engineering judgment to design the system in accordance with this general design manual. A complete evaluation of the hazards, authority having jurisdiction (AHJ) requirements, applicable laws, codes, and industry standards shall be conducted.

- System design shall include suitable safeguards to ensure prompt evacuation and to prevent entry into hazardous atmospheres, including a means for prompt rescue of trapped personnel.
- Safety items shall include personnel training, warning signs, discharge alarms, self-contained breathing apparatus, evacuation plans, and fire drills.
- Always verify that the piping system has been completely depressurized and drained immediately prior to installation, removal, adjustment, or maintenance of any Victaulic products.
- Contractors shall be certified, per local code requirements, and shall successfully complete all Victaulic training before attempting to install the system. Always reference this general design manual and consult the local authority having jurisdiction (AHJ) for complete installation requirements. This manual contains important safety and operational information.
- Nitrogen cylinders contain stored energy that can discharge explosively. Transportation and installation shall be performed only by personnel that has been trained on the hazards and proper handling techniques. All nitrogen cylinder movement shall be done with appropriate material handling equipment. Always secure nitrogen cylinders during transport, storage, and use.
- All installer-supplied piping shall conform to and be installed in accordance with requirements of this manual, applicable laws, codes, and site-specific standards, and it shall be rated for the pressure and operating conditions to which it will be subjected.
- Use only Victaulic replacement parts when servicing the system.
- Changes to hazard classifications or hazard zones may affect system performance. All changes shall be reported to the AHJ for approval.

Failure to properly design the Victaulic Vortex™ system, including determination of appropriate applications, calculation of nitrogen and water requirements, expected oxygen levels, and pipe size/system layout may result in failure to extinguish a fire, low oxygen levels, or other conditions that may result in death or serious personal injury and property damage.

If you need additional copies of any literature, or if you have any questions concerning the safe installation and operation of this product, contact Victaulic.

HAZARD IDENTIFICATION



Definitions for identifying the various hazard levels are provided below. When you see this symbol, be alert to the possibility of personal injury. Carefully read and fully understand the message that follows.

DANGER

- The use of the word "DANGER" identifies an immediate hazard with a likelihood of death or serious personal injury if instructions are not followed.

CAUTION

- The use of the word "CAUTION" identifies possible hazards or unsafe practices that could result in personal injury and product or property damage if instructions are not followed.

WARNING

- The use of the word "WARNING" identifies the presence of hazards or unsafe practices that could result in death or serious personal injury if instructions are not followed.

NOTICE

- The use of the word "NOTICE" identifies special instructions that are important but not related to hazards.

DEFINITIONS FOR "SHOULD" AND "SHALL" REFERENCES USED THROUGHOUT THIS MANUAL

References to "should" within this manual indicate areas of importance that are to be taken under consideration, but are not a requirement.

References to "shall" within this manual indicate areas of critical importance that are a requirement.

SYSTEM DESIGN FOR TOTAL FLOODING APPLICATIONS – HYBRID MEDIA QUANTITY, HYBRID EMITTER SELECTION, AND SYSTEM PERFORMANCE

Acceptable applications can be determined by referencing the FM Listing and FM Loss Prevention Data Sheets

WARNING

The Victaulic Vortex™ system SHALL NOT be used in areas that contain the following materials, unless approved by the AHJ:

- Chemicals or mixtures of chemicals, such as cellulose nitrate and gun powder, that are capable of rapid oxidation in the absence of air
- Reactive metals, such as lithium, sodium, potassium, magnesium, titanium, zirconium, uranium, and plutonium
- Metal hydrides
- Chemicals, such as certain organic peroxides or hydrazine, that are capable of undergoing autothermal decomposition

Failure to follow these instructions could result in death or serious personal injury and property damage.

Hybrid Emitter	Acceptable Operating Pressure Range	Required Water Flow Control Cartridge	Recommended Discharge Time
¼-inch PVDF	38 – 42 psi 2.6 – 2.9 Bar	0.26 GPM 1 LPM	2 Minute Minimum

HYBRID EMITTER REQUIREMENTS – WORKING SURFACE

1. Hybrid emitters installed over the working surface shall be mounted in a pendent configuration.
2. Refer to Section II of the I-VORTEX.IOM for hybrid emitter material, connection detail, nitrogen and water flow, and pressure requirements.
3. Hybrid emitters shall be placed to avoid any obstructions that can block discharge.
4. Hybrid emitters shall be placed, as shown in the drawing below.
 - Each hybrid emitter covers a maximum area of 24 x 30 inches/610 x 762 mm (5 ft²/0.5 m²).
 - Hybrid emitters shall be a vertical distance of 36 – 55 inches/914 – 1397 mm from the working surface.
 - Hybrid emitter location shall be a maximum of 8½ inches/216 mm from the sides of the working surface.
 - Hybrid emitter location shall be a maximum of 23½ inches/597 mm from the back wall of the working surface.
 - Hybrid emitter location shall be a maximum of 16 inches/406 mm from the front edge of the working surface.

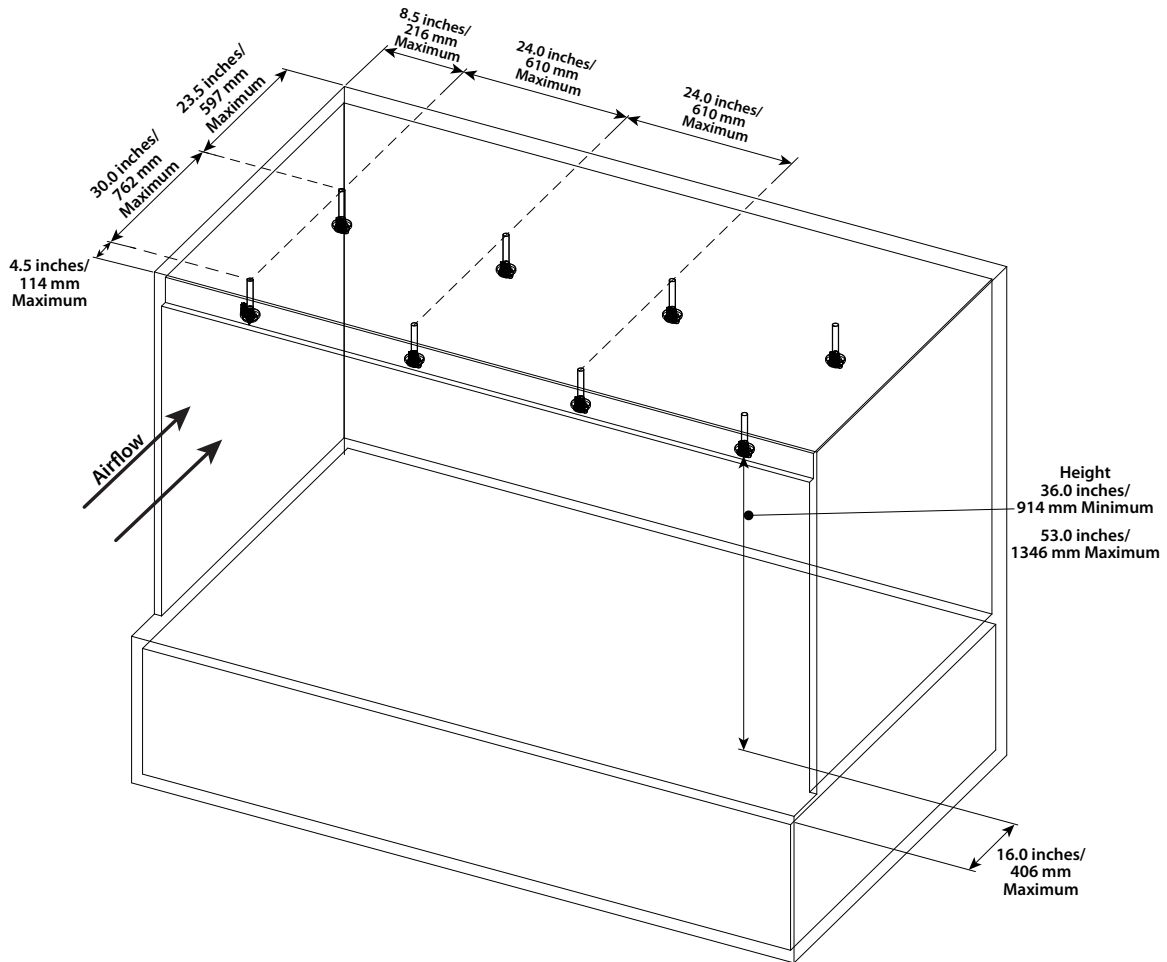

HYBRID EMITTER REQUIREMENTS – PLENUM AREA

1. Hybrid emitters installed in the plenum shall be located in a sidewall configuration along the back wall of the plenum.
2. Refer to Section II of the I-VORTEX.IOM for hybrid emitter material, connection detail, nitrogen and water flow, and pressure requirements.
3. Hybrid emitters shall be placed to avoid any obstructions that can block discharge.
4. Hybrid emitters shall be placed, as shown in the drawing below.
 - Maximum protected volume of a single hybrid emitter is 32.5 ft³/0.92 m³.
 - Maximum protected height of each hybrid emitter is 24 inches/610 mm.
 - Maximum protected depth of each hybrid emitter is 90 inches/2286 mm in the direction of discharge.
 - Hybrid emitters are to be installed mid-height of the space, projected horizontally.
 - Maximum hybrid emitter spacing is 24 inches/610 mm.

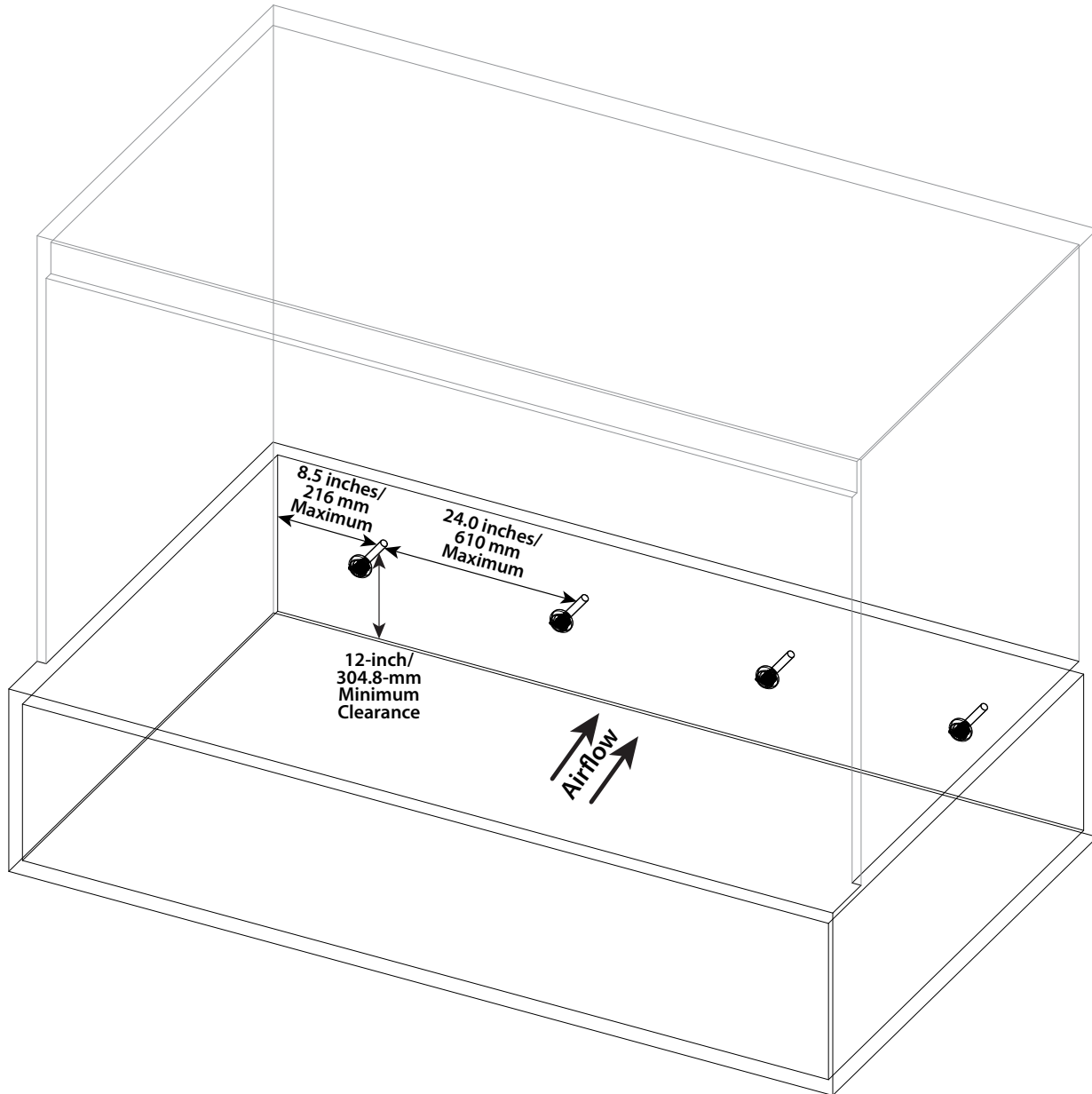

UNVENTILATED AUXILIARY COMPARTMENTS

1. Unventilated auxiliary compartments with minimal leakage may be protected by hybrid emitters that discharge nitrogen only in pendent or sidewall configurations.
2. When water is not used, the water connection on the hybrid emitter shall be plugged.
3. Use one hybrid emitter per 65 ft³/1.8 m³ of compartment volume.
4. Hybrid emitters shall be placed to avoid any obstructions that can block discharge.

CALCULATE THE NUMBER OF HYBRID EMITTERS REQUIRED

Calculate the number of hybrid emitters required.	Reference the "Working Surface," "Plenum Area," or "Unventilated Auxiliary Compartments" sections to determine the area that each hybrid emitter covers.
---	--

DETERMINE THE REQUIRED DISCHARGE TIME

Determine the discharge time based on the application and the relevant FM Data Sheets	2 minutes minimum
---	-------------------

CALCULATE THE NITROGEN QUANTITY REQUIRED

Nitrogen required for a zone is determined by the desired length of extinguishment flow and the number of emitters. Working surface and plenum designs have a 2-minute discharge requirement.	Nitrogen Quantity Required = Number of Hybrid Emitters x 2 Minutes x 40 SCFM
---	--

CALCULATE THE WATER QUANTITY REQUIRED

The water requirement may be determined by multiplying the number of hybrid emitters by the hybrid emitter water flow requirements and discharge time.	$W_{\text{water}} = q_{\text{water}} \times n_{\text{hybrid emitters}} \times t_{\text{discharge}}$ <p>Where: W_{water} = Water Discharged from System q_{water} = Hybrid Emitter Water Flow (GPM) $n_{\text{hybrid emitters}}$ = Number of Hybrid Emitters Required $t_{\text{discharge}}$ = Design Discharge Time in Minutes (Page 2)</p>
--	---

CALCULATE THE NUMBER OF CYLINDERS REQUIRED

Determine the number of cylinders required by dividing the nitrogen required by the nominal volume of the cylinders, then round up. Refer to Section II of the I-VORTEX.IOM for cylinder capacities. In all cases, an evaluation of the possible and expected oxygen levels shall be performed and appropriate training shall be provided.	$n_{\text{cylinder}} = \frac{W_{\text{N2_req}}}{W_{\text{usable cyl}}}$ <p>Where: n_{cylinder} = Number of Cylinders Required $W_{\text{N2_req}}$ = Quantity of Nitrogen Gas (SCF) $W_{\text{usable cyl}}$ = Usable Cylinder Volume (SCF) (Page 6)</p>
---	---

CALCULATE THE REQUIRED NITROGEN FLOW

Divide the required nitrogen by the desired discharge time to find the minimum nitrogen flow required from the total of all hybrid emitters in the hazard.	$Q_{\text{N2_min}} = \frac{W_{\text{N2_req}}}{t_{\text{discharge}}}$ <p>Where: $Q_{\text{N2_min}}$ = Minimum Nitrogen Flow (SCFM) $W_{\text{N2_req}}$ = Quantity of Nitrogen Gas (SCF) $t_{\text{discharge}}$ = Design Discharge Time in Minutes (Page 2)</p>
--	---

CALCULATE THE EXPECTED OXYGEN LEVEL

<p>Where: $O_2\%_{\text{actual}}$ = Oxygen Level for Cold Discharge n_{cylinder} = Number of Cylinders Required W_{cyl} = Cylinder Volume (SCF) (Page 6) V = Volume of Hazard (ft³) ACF = Atmospheric Correction Factor (From NFPA 770 Table 8.4.1.3, Atmospheric Correction Factors) T = Enclosure Temperature in Kelvin T_o = Standard Temperature (see "NOTE" above)</p> <p>NOTES: In the event of a fire, the oxygen level will be further reduced as a result of the combustion process. The oxygen level will be lower at elevated enclosure temperatures. It may be necessary to verify oxygen levels at nominal and maximum expected enclosure temperatures.</p>	$O_2\%_{\text{actual}} = 20.95e^{-\left(\frac{n_{\text{cylinder}} \times W_{\text{cyl}}}{V \times ACF} \times \frac{T}{T_o}\right)}$
--	--

CALCULATE THE WATER TANK CAPACITY

Additional water, equal to the volume of the water piping system, is required. Victaulic recommends applying an additional 20% safety factor above the hybrid emitter requirements, plus the pipe volume. During a system discharge, the Victaulic Vortex™ Panels regulate the water flow. Using a larger-than-required water tank will not cause excessive water to be applied to the space.	$W_{\text{tank}} = (W_{\text{water}} + W_{\text{pipe}}) \times \text{S.F.}$ <p>Where: W_{tank} = Minimum Water Tank Capacity W_{water} = Water Discharged from System W_{pipe} = Volume of Water That Will be Dry at Start of Discharge S.F. = Safety Factor (1.25 per FM Listing)</p>
--	--

Cylinder Capacity

The nitrogen requirement is determined by the hazard zone size, pipe size, number of hybrid emitters, discharge time, and pipe lengths to individual hazard zones. Nitrogen is stored in the cylinders as a gas. Verify the gas supplier's refill capability and determine the corresponding nitrogen cylinder capacity before designing the system. The cylinder volumes listed in the table below are the amount of nitrogen that will be discharged from cylinders into the piping and enclosure. Refer to Victaulic publication 70.04 for complete nitrogen cylinder material specifications and dimensions.

Capacities for 80-Liter Nitrogen Cylinder

Pressure at 70° F/21° C	Approximate Nominal Cylinder Volume	Cylinder Volume
2100 psi 144.8 Bar	384 SCF 10.9 Sm ³	399 SCF 11.3 Sm ³
2200 psi 151.7 Bar	403 SCF 11.4 Sm ³	418 SCF 11.8 Sm ³
2300 psi 158.6 Bar	418 SCF 11.8 Sm ³	432 SCF 12.2 Sm ³
2400 psi 165.5 Bar	436 SCF 12.4 Sm ³	451 SCF 12.8 Sm ³
2500 psi 172.4 Bar	449 SCF 12.7 Sm ³	464 SCF 13.1 Sm ³
2600 psi 179.3 Bar	459 SCF 13.0 Sm ³	474 SCF 13.4 Sm ³
2640 psi 182.0 Bar	475 SCF 13.5 Sm ³	490 SCF 13.9 Sm ³
2700 psi 186.2 Bar	486 SCF 13.8 Sm ³	501 SCF 14.2 Sm ³
2800 psi 193.1 Bar	504 SCF 14.3 Sm ³	519 SCF 14.7 Sm ³
2900 psi 199.9 Bar	515 SCF 14.6 Sm ³	530 SCF 15.0 Sm ³
3000 psi 206.8 Bar	534 SCF 15.1 Sm ³	549 SCF 15.5 Sm ³

NOTE: Unless noted otherwise in this manual, standard temperature is 294.4K (70°F) for values stated in SCF and Sm³.



**Temperature Effects on Nitrogen Pressure
80-liter Cylinder with 2400-psi/165.5-Bar Nominal Fill**

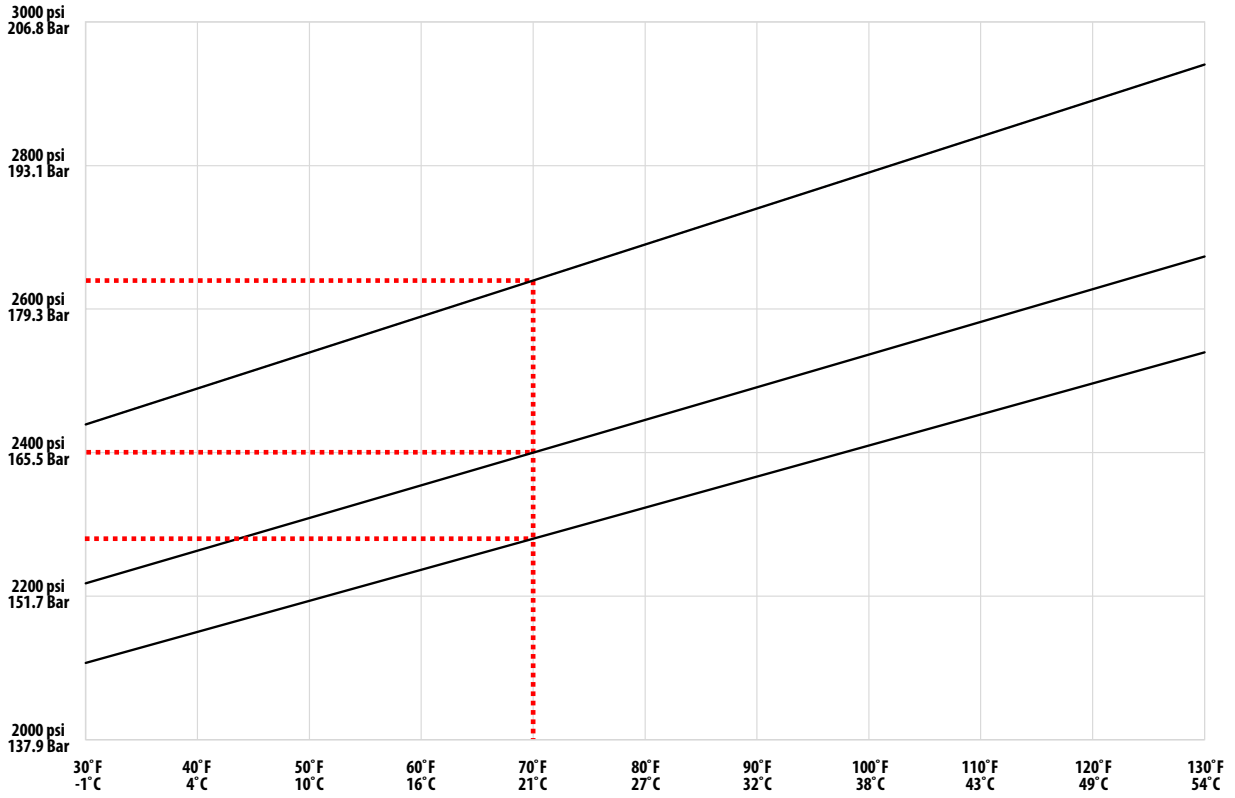

**Temperature Effects on Nitrogen Pressure
80-liter Cylinder with 3000-psi/206.8-Bar Nominal Fill**

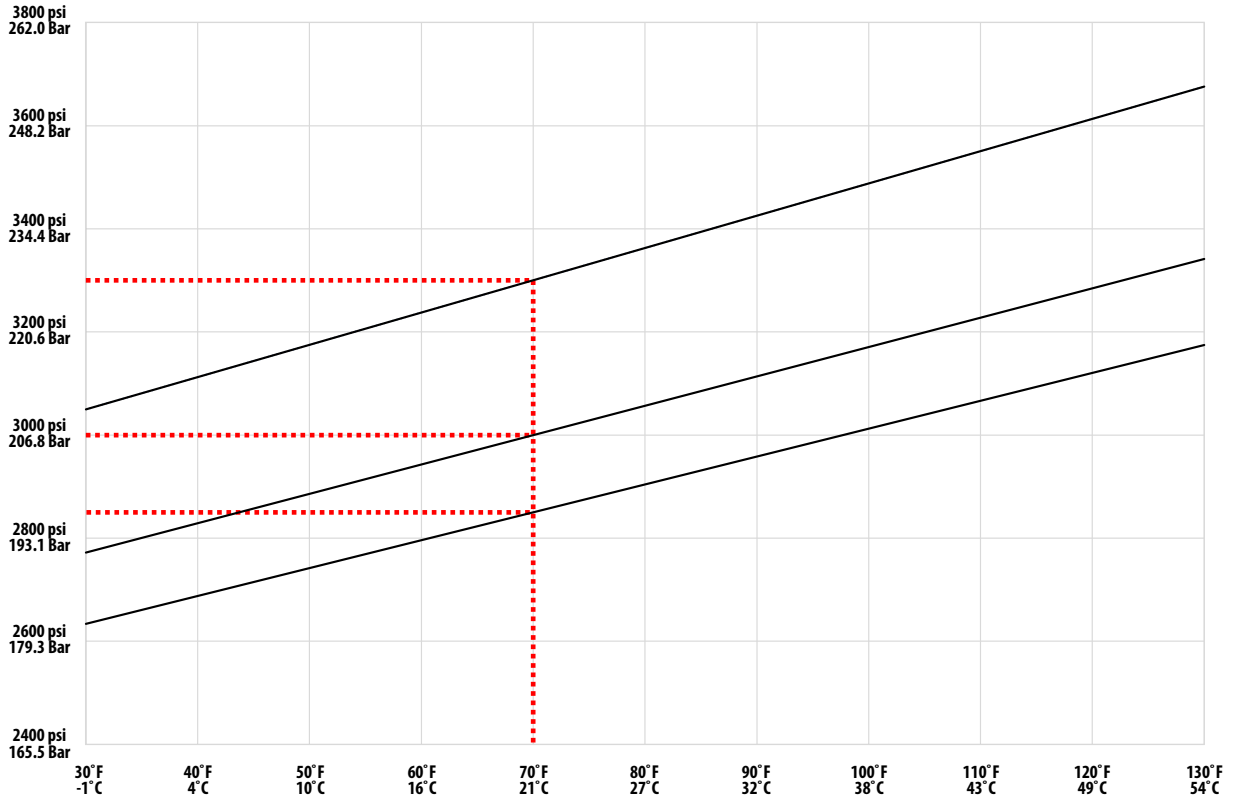

SINGLE-ZONE SYSTEM

A single-zone system utilizes a Combination Panel to regulate the flow of nitrogen and water to the hybrid emitters. In addition, a single-zone system incorporates an approved agent-releasing panel and detection installed in accordance with the manufacturers' recommendations.

A pressure relief valve is required in single-zone systems where the combined flow capability of the hybrid emitters is less than 150 SCFM/ 255 m³/hr to ensure that pressure does not build up greater than the pipe rating. The pressure relief valve is installed in the low-pressure nitrogen piping and shall be vented to outside the building (or to a space sufficiently large enough to prevent a low-oxygen condition during relief valve operation).

Single-Zone System Connection Diagram

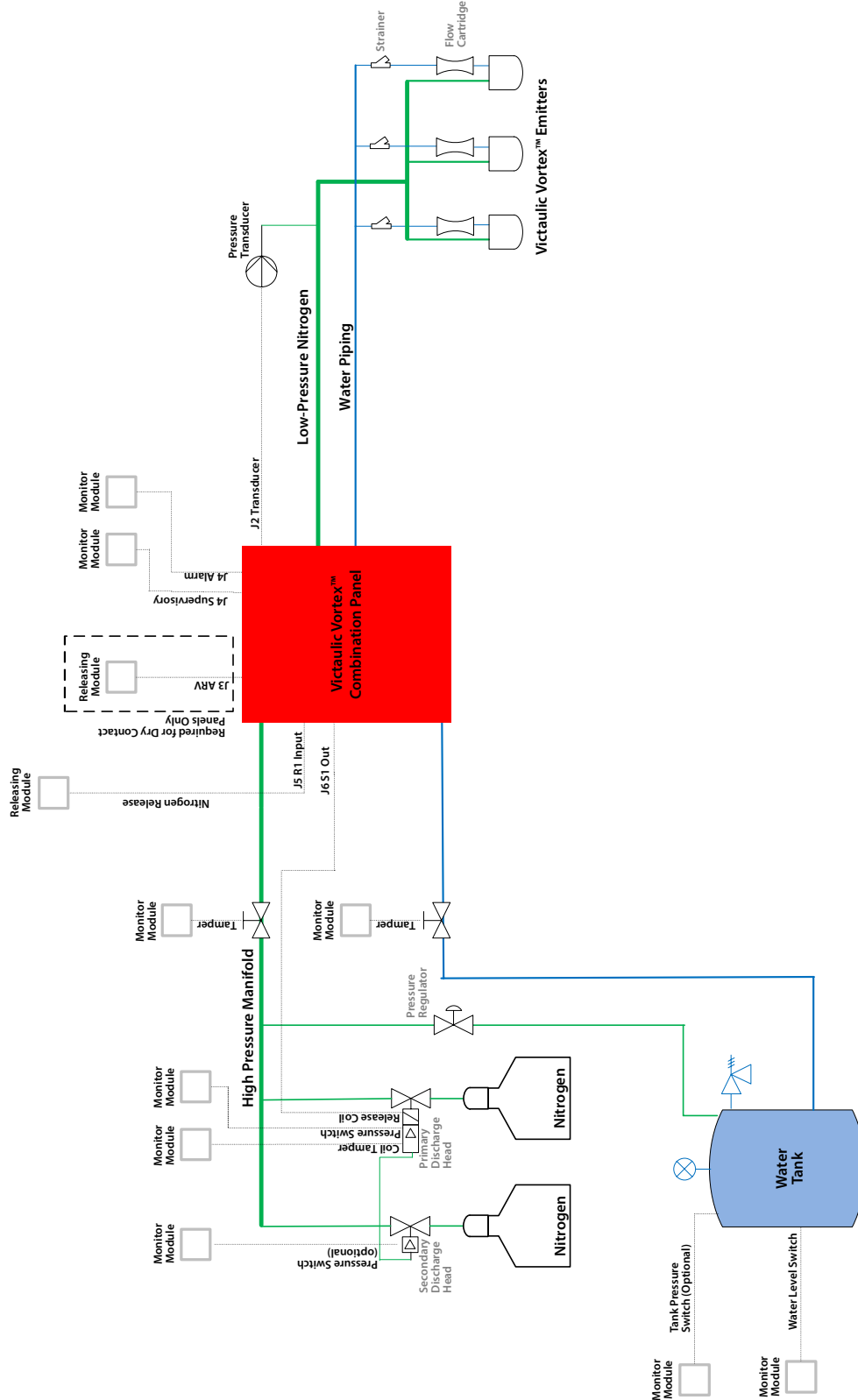

Parallel Panels for Large Single-Zone System (Active Release Panels)

For larger hazards, where flows exceeding the ratings of a single Victaulic Vortex™ Panel are required, multiple panels may be used either with a shared nitrogen and water source, as shown, or as multiple individual systems that are triggered at the same time. When multiple panels with a shared nitrogen source are used, the release signal shall be routed through every Victaulic Vortex™ Panel to avoid allowing the nitrogen supply to be activated (opened) when a panel is not in the ready state.

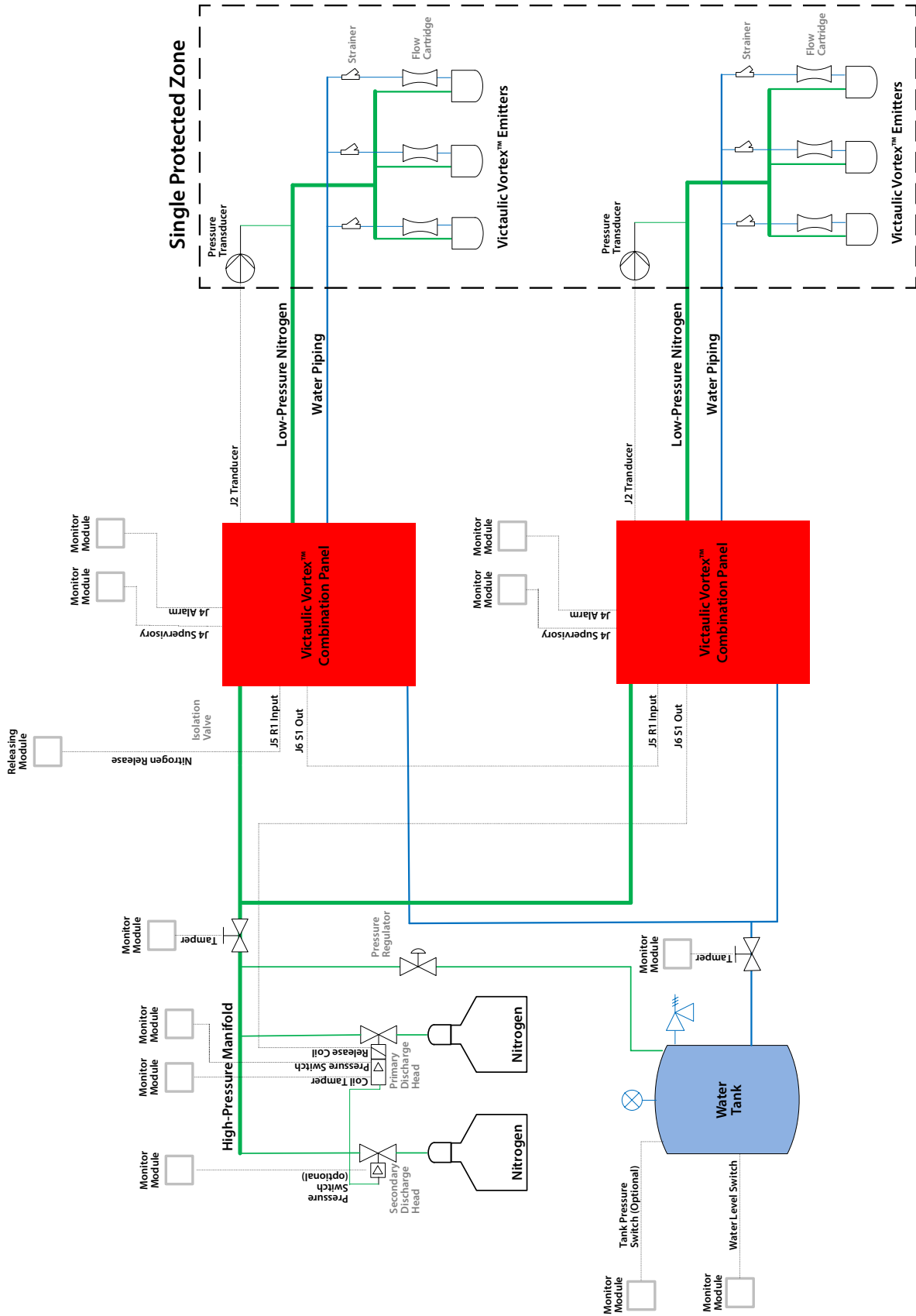

MULTI-ZONE SYSTEM

A multi-zone system uses a common nitrogen and water source to provide protection for multiple zones. Multi-zone systems may be implemented by using multiple Combination Panels (shown below) or by utilizing Fluid and Zone Panels (refer to the following page). Utilizing multiple Combination Panels allows placement of pressure transducers closer to hybrid emitters and provides more accurate pressure regulation. Utilizing Combination Panels to implement multi-zone systems is preferred when zones are different sizes or when low-pressure piping to hybrid emitters is not symmetrical. The quantities of nitrogen and water shall accommodate the largest single hazard or group of hazards being protected.

Two-Zone System Connection Diagram (Dry Contact Panels)

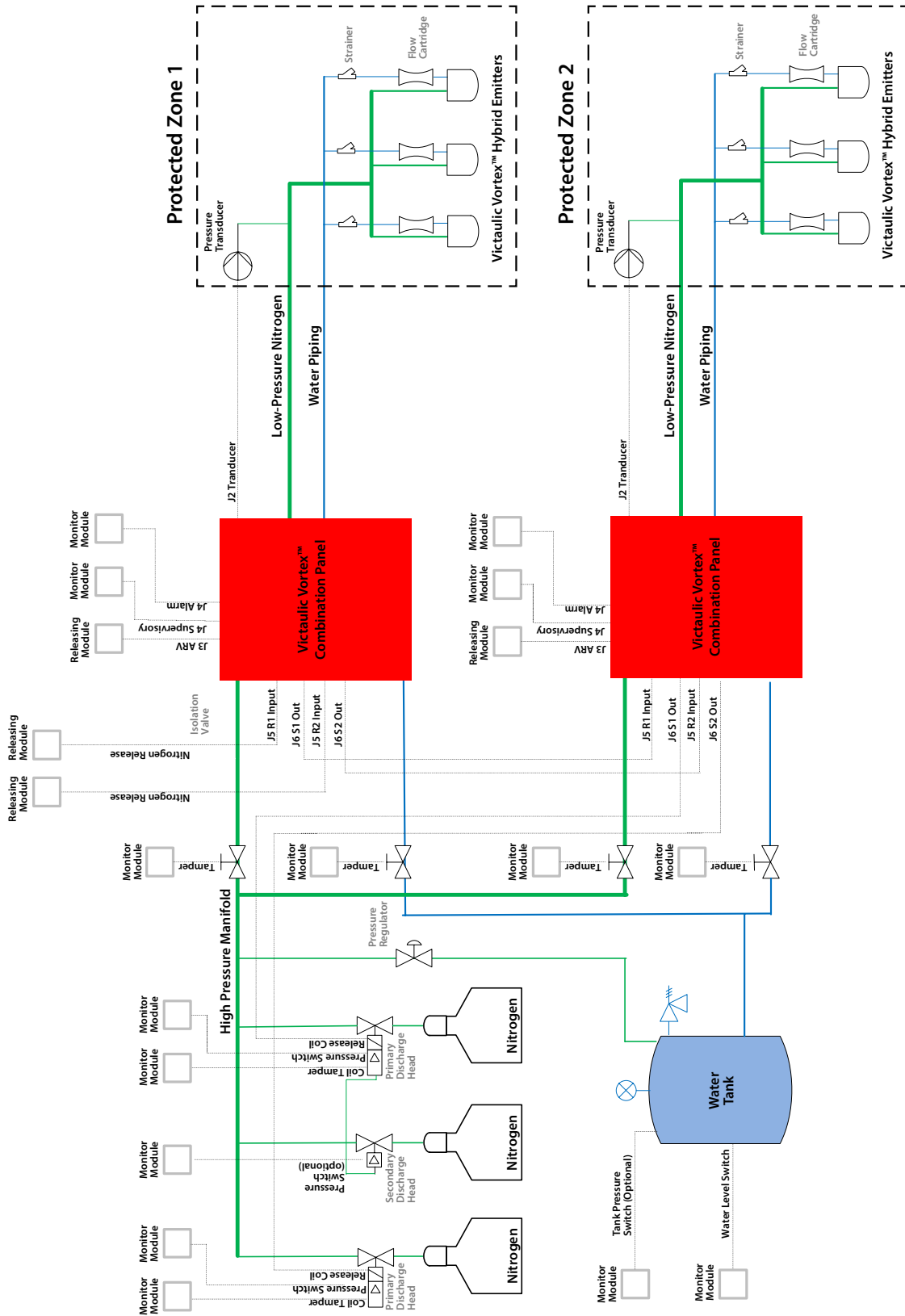

Two-Zone System Connection Diagram (Fluid and Zone Panels)

Multi-zone systems may also be designed using Fluid and Zone Panels. The Fluid and Zone Panel arrangement is most efficient when there are more than three zones that are equally-sized and equidistant from the Fluid and Zone Panels. In a Fluid and Zone Panel system, the pressure transducer is further away from the hybrid emitters, and a more rigorous analysis of pressure drop is typically required. The pressure drop from the pressure transducer to the hybrid emitters of each zone shall be equal to allow a single pressure setting to work for all zones.

- The agent-releasing FACP shall control which Zone Panel is activated based on detection input.
- A pressure relief valve is required in multi-zone systems to ensure that pressure does not build up greater than the pipe rating.
- The pressure relief valve is installed in the low-pressure nitrogen piping between the Fluid Panel and Zone Panel and shall be vented to outside the building (or to a space sufficiently large enough to prevent a low-oxygen condition during relief valve operation).

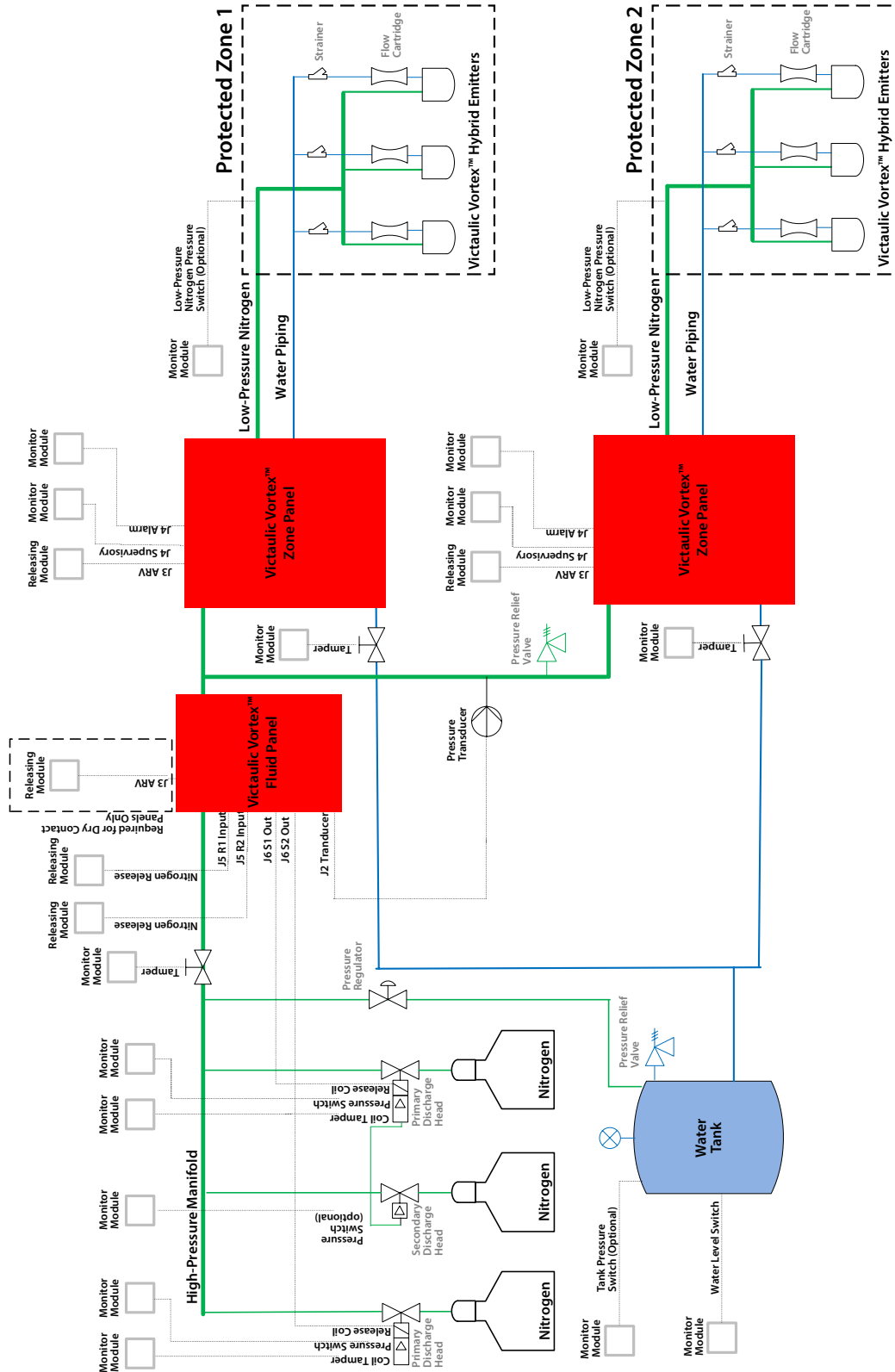

Two-Zone System Connection Diagram (Bulk Tube and Dry Contact Panels)

Multi-zone systems may be designed to use nitrogen storage in bulk tubes. Typically, these systems will use Dry Contact Panels so that specific panels can be discharged when nitrogen is released. **NOTE:** Active release panels will begin discharging when pressure is sensed at the outlet and shall be used only when all panels will be discharged simultaneously.

The fire alarm and releasing circuit design shall include safeguards to prevent the nitrogen bulk tube valve from being opened when the needle valves in the Victaulic Vortex™ Panels are not fully seated (closed).

Typically, a timer will open and close a nitrogen bulk tube to provide the required amount of nitrogen. The nitrogen delivered to the protected space shall be determined by emitter flow rate(s) and discharge time when the nitrogen bulk tube is open for a set amount of time.

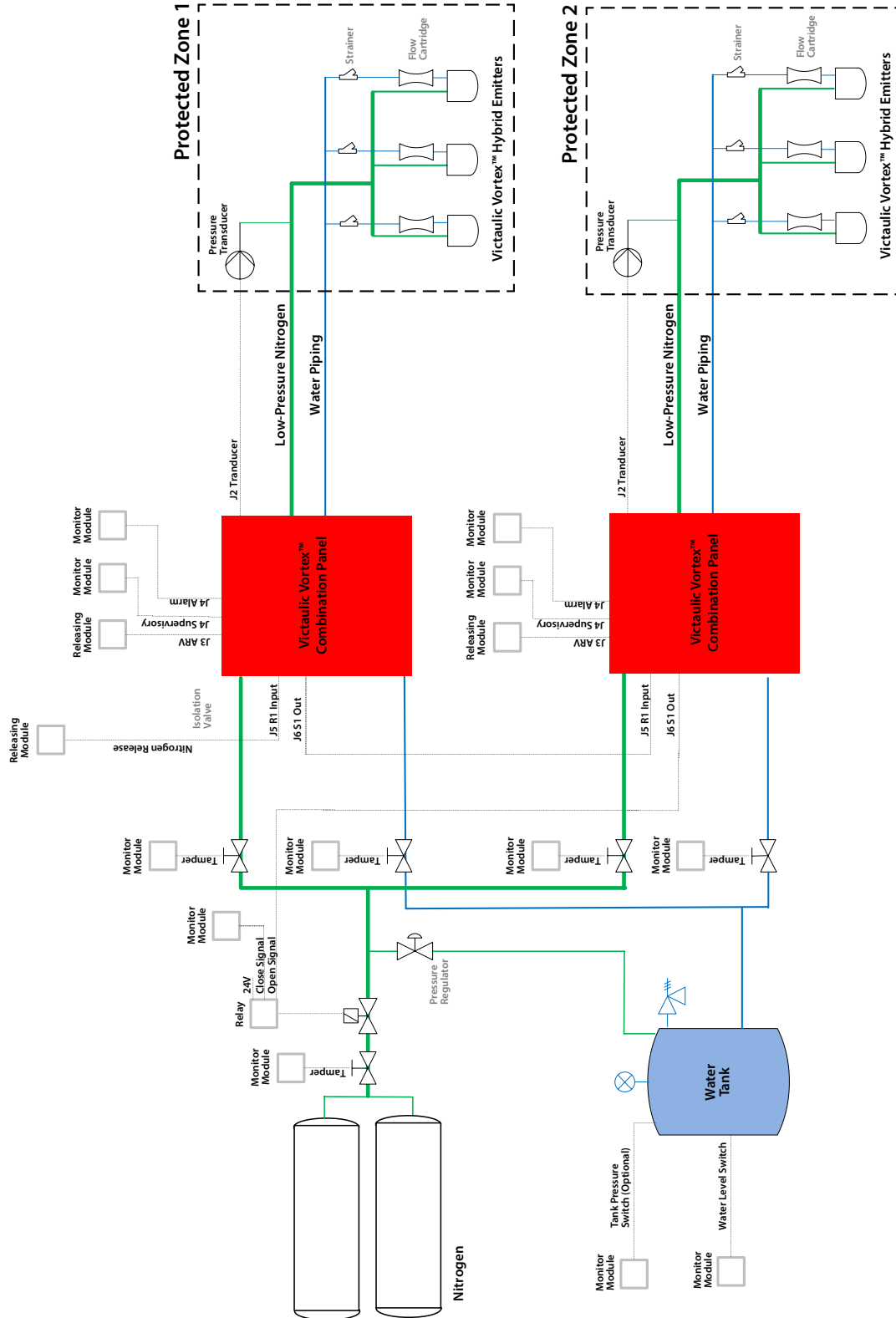

NITROGEN RESERVE SYSTEM CONNECTION DIAGRAM

For applications where the system needs to be returned to service quickly after a discharge, or as required by the AHJ, a second set of nitrogen cylinders may be provided as a reserve system.

Selection of the reserve system is implemented using a main/reserve switch. The system designer and AHJ shall consider site conditions, hazards, and all applicable laws, codes, and industry standards when determining how nitrogen pressure and isolation valve supervision are to be switched to the alternate bank when the release signal is switched. Discharge hose restrictor valves shall be utilized to limit hose movement in the event of a hose separation. The water supply may be sized to accommodate two discharges, plus a safety factor.

Following a discharge of the main nitrogen supply:

- Verify that the Victaulic Vortex™ Panel has been reset and that the ARV is seated and fully closed before switching to reserve (or back to main).
- Refill the water tank and follow the procedures for "Returning the System to Service after Discharge" (Refer to the I-VORTEX.IOM).
- Verify that the pilot lines have been bled and all cylinder valves are closed.

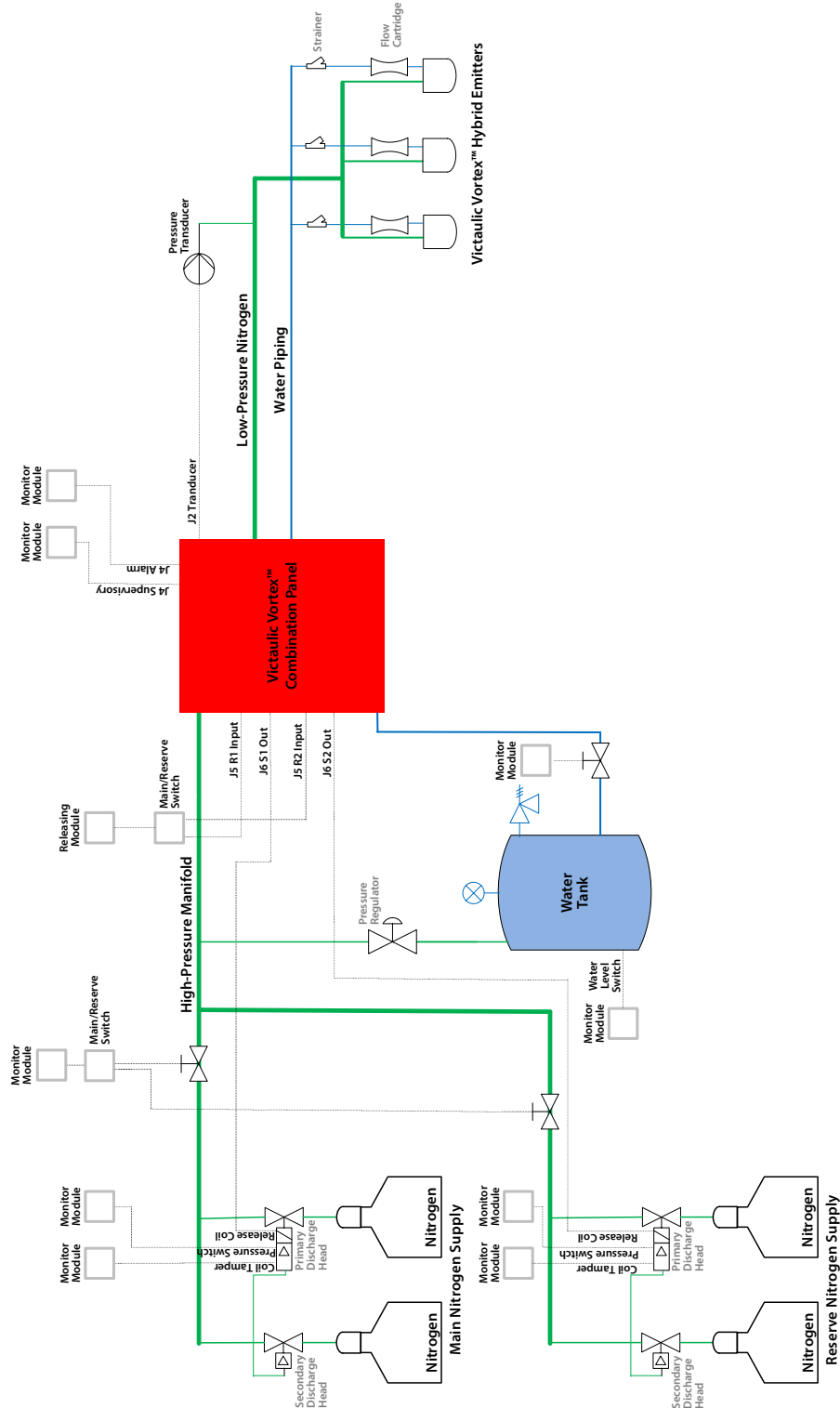

OPTIONAL TEST CONNECTION, PRESSURE SWITCH AND MONITOR MODULE, AND SUPERVISED AUXILIARY DRAIN VALVE(S) FOR HYBRID EMITTER PIPING

Some Victaulic Vortex™ system installations may benefit from additional integrator-supplied components. The diagram below shows an optional test connection, pressure switch and monitor module, and supervised auxiliary drain valves that shall be considered.

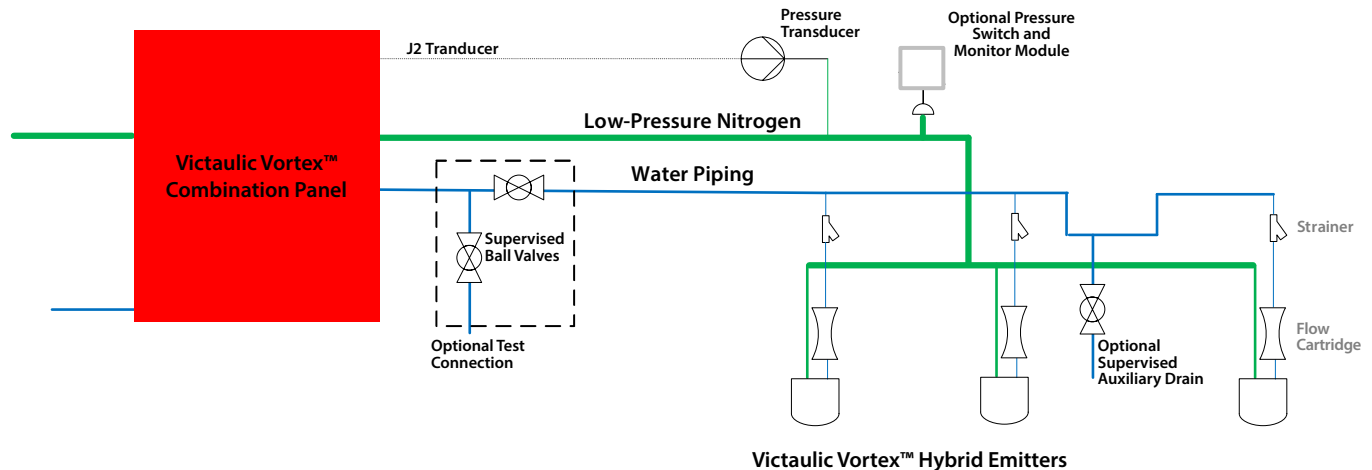

Test Connection

FM Data Sheet 4-6 recognizes that a test connection may be provided to verify water or nitrogen flow. When discharging water into the space is not practical for acceptance testing and inspection, a test connection shall be installed:

- Ball valves shall be supervised
- Supervised test connection ball valves shall be installed between the Victaulic Vortex™ Panels and hybrid emitters
- An alternative configuration is to provide a supervised test connection at the furthest hybrid emitter and then plug the water connection at each hybrid emitter during testing

In most applications, a test connection only on the water line will provide the greatest benefit with the least amount of additional components. Typically, test connections are not required on the nitrogen line. If a test connection is placed in the nitrogen piping, a thorough review of system operation, along with the test process, shall be conducted to ensure that:

- Nitrogen flow remains within the capabilities of the Victaulic Vortex™ Panel
- The pressure transducer is not isolated from panel output
- The discharged nitrogen is directed away from personnel and movable objects
- All components remain within rated pressures

DO NOT allow operation of the system with the nitrogen piping blocked or closed. Nitrogen shall be able to discharge from the panel outlet to atmosphere to avoid over-pressurization. Install an appropriately-sized relief valve between the panel outlet and test connection.

If a test connection is placed in the water piping, a thorough review of the test process shall be conducted to ensure that:

- Water is directed into a drain capable of handling the expected volume and flow

Supervised Auxiliary Drain (Part Code S004N69106)

When the water piping configuration may prevent proper drainage after a discharge, or for critical applications, a supervised auxiliary drain valve shall be installed:

- Supervised auxiliary drains shall be FM Approved
- Supervised auxiliary drain may be manually or automatically actuated
- Supervised auxiliary drains shall drain to an area capable of handling the maximum anticipated discharge
- To minimize probability of water dripping from hybrid emitters after discharge, the FACP shall activate a supervised automated drain valve after discharge is complete
- System acceptance testing shall include testing timing and sequencing of any automated valves

When additional monitoring of system discharge and alarm state is required, an auxiliary pressure switch and monitor module may be installed in the hybrid emitter low-pressure nitrogen piping. Nitrogen flows when the low-pressure nitrogen piping is pressurized. The nitrogen pressure switch shall be set to match the water turn-on pressure of the Victaulic Vortex™ Panel, which will provide the best indication of when hybrid media is being discharged. Acceptance testing of the pressure switch requires a discharge test with nitrogen, removal of the pressure switch from the system for bench testing, or application of static pressure to the low-pressure hybrid emitter piping.

Nitrogen Discharge Pressure Switch (Optional) (Part Code S000760044)

When it is necessary to indicate that the low-pressure nitrogen piping is pressurized, a pressure switch may be added to the low-pressure piping. The pressure switch shall be FM Approved.

PIPING LAYOUT INTRODUCTION

The Victaulic Vortex™ system requires nitrogen pressure at the hybrid emitters to be within their rated operating pressures for proper operation. Pipe sizing and layout are critical to keep the hybrid emitters operating at approximately equal pressures and within their rated operating pressures. Refer to the applicable pipe sizing table included in this section.

The Victaulic Vortex™ system incorporates a pressure transducer feedback loop in the nitrogen piping that monitors and provides data to the ARV.

The piping system shall be designed to meet the following requirements:

- 1) Minimum 25 psi/1.7 Bar at furthest hybrid emitter flow control cartridge
- 2) Water delivery within 30 seconds to furthest hybrid emitter flow control cartridge
- 3) Flow rate requirements are determined by quantity of hybrid emitters required in the system
- 4) Water source shall be capable of overcoming all pressure losses in construction layout and meet the above requirements

Water delivery time calculations shall consider any length of pipe that must be filled with water when the water valve in the Victaulic Vortex™ Panel opens. In typical applications, nitrogen pressure is applied to the input of the Victaulic Vortex™ Panel slightly before the needle valve begins to open, and several seconds before the water valve begins to open. In a typical discharge, this allows water to fill the piping up to the inlet of the Victaulic Vortex™ Panel.

Water supply piping shall be installed to have a minimum pitch of ¼ inch/6.4 mm per 10 feet/3.0 meters back to the Combination or Zone Panel to allow for proper drainage. The Combination Panel incorporates an automatic drain solenoid, and the Zone Panel contains a manually-operated ball valve drain. Additional low-point drains in the piping may be required for complete drainage of the water line.

Flushing and Cleaning of Piping



Each pipe and tube section shall be cleaned internally after preparation and before assembly, in accordance with standard piping practices. The piping network shall be free of particulate, threading chips, and oil residue before any hybrid emitters are installed.



The piping distribution system shall be inspected to determine that it is in compliance with design and installation documentation (refer to applicable drawings).



A flow test using nitrogen gas or compressed air shall be performed on the piping network to verify that flow is continuous and that piping and hybrid emitters are unobstructed.

NOTICE

- Victaulic Vortex™ system components shall be protected from damage. Depending on the hazard, system components (except for hybrid emitters, strainers, water flow control cartridges, and required piping), shall be located outside the hazard zone.
- Care shall be taken in determining the location of the nitrogen supply, since an accidental release of nitrogen may result in a low-oxygen condition in the area.
- The protected enclosure shall have the structural strength and integrity necessary to contain the nitrogen discharge. If the developed pressures present a threat to the structural strength of the enclosure, venting shall be provided to prevent excessive pressures. Any powered venting shall be considered in the design. Designers/installers shall consult with Victaulic regarding powered venting or to account for any necessary enclosure venting. It is critical to verify that over-pressurization falls within acceptable limits.

MATERIAL SPECIFICATIONS

Nitrogen Piping

High-pressure nitrogen supply lines and fittings shall meet ASME B31.1 and all applicable codes and shall be rated to at least 3000 psi/206.8 Bar or the maximum supply pressure of the nitrogen supply. Low-pressure nitrogen piping to the hybrid emitters may consist of several different pipe materials, coatings, and schedules. Pressure relief valves are required in low-pressure nitrogen piping in multi-zone systems and single-zone systems with less than 150 SCFM/255 m³/hr hybrid emitter flow.

Low-pressure nitrogen hybrid emitter piping (downstream of the ARV) may be comprised of minimum Schedule 10 carbon steel pipe and/or galvanized pipe or Schedule 5 stainless steel pipe for 3-inch/88.9-mm and smaller diameter piping.

Refer to the hybrid emitter specifications for the rated operating pressures. Piping layout and sizes shall be designed to keep all hybrid emitters within their recommended operating pressures.

Water Piping

Water supply piping used in the Victaulic Vortex™ system shall have a minimum working pressure rating of 175 psi/12.1 Bar and shall meet or exceed standards specified in NFPA 770.

Water supply piping may be copper tubing, PVDF or stainless steel pipe. Copper tubing wall thickness may be Type K, L, or M. The water pipe connection from the water flow control cartridge to the hybrid emitter shall be copper tubing or stainless steel tubing that is sized appropriately for flow and delivery time.

Piping Drainage

Pipe shall be pitched back to the Victaulic Vortex™ Panel for best drainage. If there is potential for trapped water, or for sections of pipe that may pitch toward the hybrid emitter, consider placing drain valves in the hybrid emitter water piping.

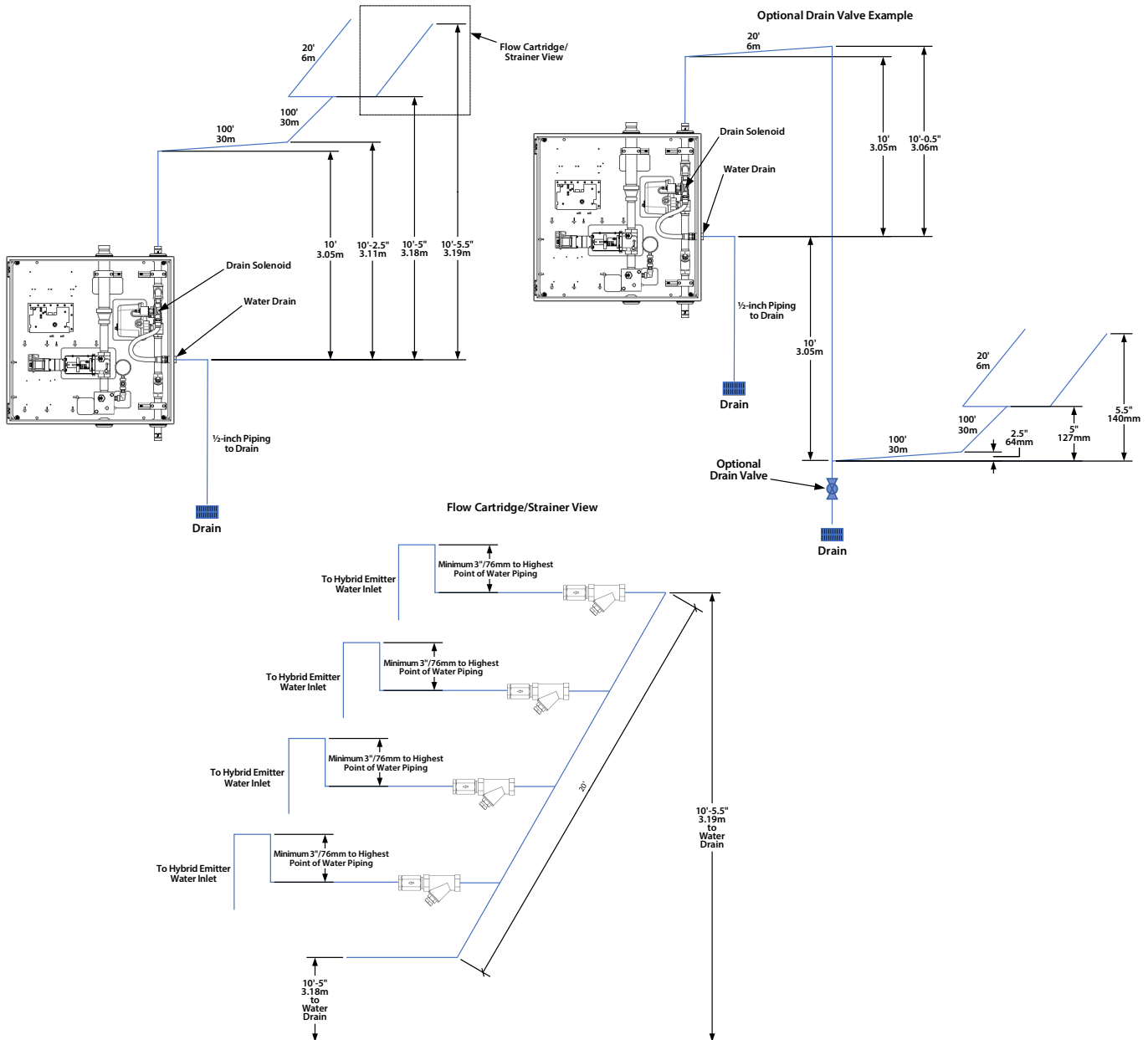

Lockout/Tagout

Victaulic offers, and requires, a supervised nitrogen isolation valve at the nitrogen source and a supervised water isolation valve at the water source. Evaluate your site's lockout/tagout requirements (where applicable), particularly when multiple Combination or Fluid Panels are installed in parallel or when a reserve nitrogen supply is required. Additional lockout valves may be installed at the inlet to Combination or Fluid Panels, at the inlet to water tank pressure regulators, or at other locations in the system consistent with applicable safety requirements. DO NOT install nitrogen lockout valves on the outlet of Combination or Fluid Panels, or on the inlet of Zone Panels. Closed isolation valves shall not result in over-pressurization of any component in the event of a discharge.

High-Pressure Cylinder Manifold

The standard Victaulic Vortex™ high-pressure manifold is 2-inch Schedule 160 carbon steel pipe. Typically, a high-pressure header with an increased pipe size is recommended when the maximum nitrogen flow rate exceeds 4500 SCFM. The high-pressure header reduces friction loss to the inlet of the Victaulic Vortex™ Panels. The addition of this piping reduces the amount of nitrogen flowing the length of the 2-inch Schedule 160 high-pressure manifold, reducing the amount of pressure drop through the manifold. The excessive pressure drop becomes critical when the cylinder pressures begin to decay below 1000 psig/68.9 Bar during the discharge. Victaulic Vortex™ Panels need a minimum of 400 psig/27.6 Bar inlet pressure to regulate nitrogen at the maximum nitrogen flow rate of the specific panel. The reduction in friction loss to the panel increases the nitrogen regulation period, which leads to increased system performance.

Manifold Layout Guidance

Maximum Nitrogen Flow Rate "Y" (For 20% Pressure Drop)	Maximum Distance "X" (For Series-Connected Victaulic Vortex™ 2-inch Manifolds)*
4000 SCFM 113 Sm ³ /minute	80 feet 24 meters
5000 SCFM 142 Sm ³ /minute	50 feet 15 meters
6000 SCFM 170 Sm ³ /minute	40 feet 12 meters
7000 SCFM 198 Sm ³ /minute	25 feet 8 meters

* Maximum 3 feet of 1.5-inch Schedule 160 between manifolds in series
Refer to "Upstream of Victaulic Vortex™ Panel (High-Pressure Piping)" table (Page 21)

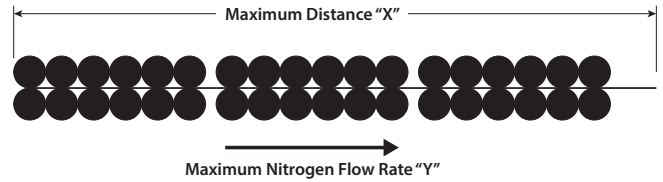

NOTICE

- Refer to the "Maximum Recommended Nitrogen Flow According to Pipe Size - Upstream of Victaulic Vortex™ Panel (High-Pressure Piping)" table (Page 21) when sizing the high-pressure header.

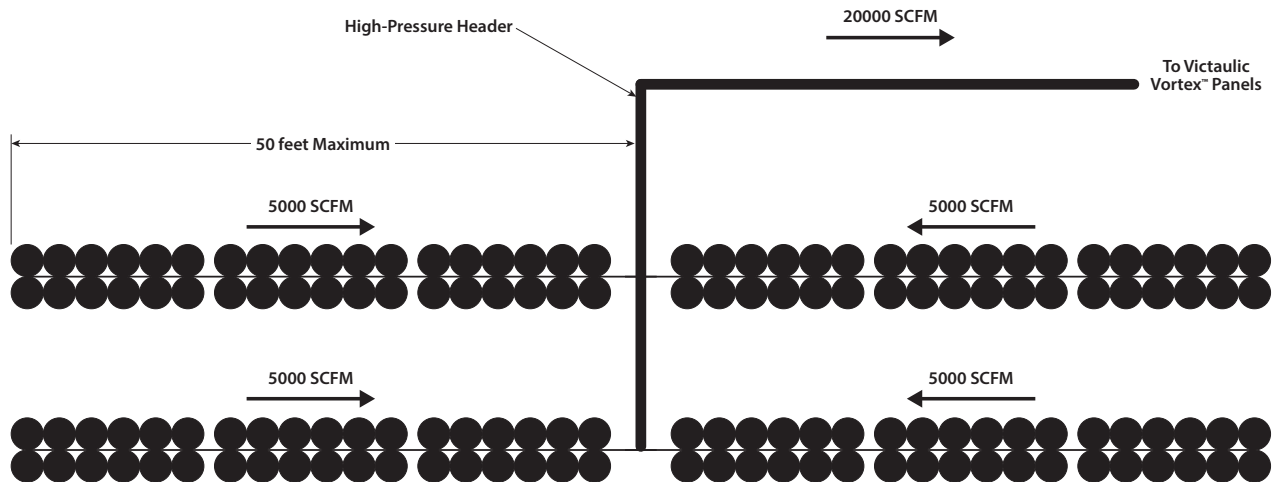

Pipe Support and Connections

Hangers shall be approved for the pipe being installed. Refer to NFPA 13 for low-pressure piping and ASME B31.1 for high-pressure piping, and consult with the local AHJ to determine requirements for seismic bracing.

WARNING

- Pipe joining methods shall comply with the manufacturer's installation requirements.
- Pipe size, schedule, and material shall be appropriate for the environment in which it is used.
- Pipe size, schedule, and material shall meet all applicable local and national codes.

Failure to follow these instructions could cause improper system operation, resulting in serious personal injury and/or property damage.

Couplings and fittings shall be standard Victaulic products containing Grade "E", Grade "E" Type A, or Grade "EHP" EPDM gaskets.

Refer to Section II of the I-VORTEX.IOM for the applicable panel dimensions and pipe inlet and outlet requirements.

PIPING LAYOUT DEFINITIONS

Feed Main - Primary supply line up to the separated feed or branch line

Cross Feed Main - Reduced piping diameter from the main feed to the branch line

Branch Line - Piping from the feed line (main/separated) to the hybrid emitter

HYBRID EMITTER ACCESSORIES

The water flow control cartridge, installed at each hybrid emitter, regulates water flow if the required inlet pressure at the water flow control cartridge is maintained. (Refer to Section II of the I-VORTEX.IOM)

It is recommended that the piping be pitched at least ¼ inch/ 6.4 mm per 10 feet/3 meters toward the system drain (located in the Combination or Zone Panel) or integrator-provided, low-point drain.

A strainer and water flow control cartridge shall be installed for each hybrid emitter. The strainer and water flow control cartridge shall be installed in an accessible location for servicing, and it shall be installed in close proximity to the hybrid emitter (maximum of 3 feet/0.9 meters, or as required by water delivery time). The strainer protects the water flow control cartridge and hybrid emitter from potential debris.

WARNING

- Hybrid emitter selection and installation shall be based upon the hazard being protected.

Failure to follow this instruction will cause improper system operation, resulting in death or serious personal injury and property damage.

HYBRID EMITTER PLACEMENT

The piping system shall be designed to minimize pressure differences between hybrid emitters and minimize pressure losses between the Victaulic Vortex™ Panel and hybrid emitters. The allowable pressure difference at each hybrid emitter is -10%/+20% of the rated pressure.

- Hybrid emitters shall be distributed throughout the protected space to provide even distribution of hybrid media.
- Hybrid emitters may be angled to optimize distribution and minimize obstruction in front of the hybrid emitter
- Hybrid emitters may be aimed at specific equipment, if required
- Avoid direct impingement on or installation directly above electrical or other moisture-sensitive equipment where dripping after discharge could result in damage
- Large, flat surfaces (such as equipment cabinets and furniture) directly in the path of hybrid emitter discharge may collect water. A minimum clearance of 18 inches/457 mm is recommended. The preferred method is to position hybrid emitters to use the full height (pendent) or full width (sidewall) of the enclosure.
- Avoid configurations where discharge of the hybrid emitter could cause splashing of flammable materials.

Hybrid Emitter – Working Surface Detail

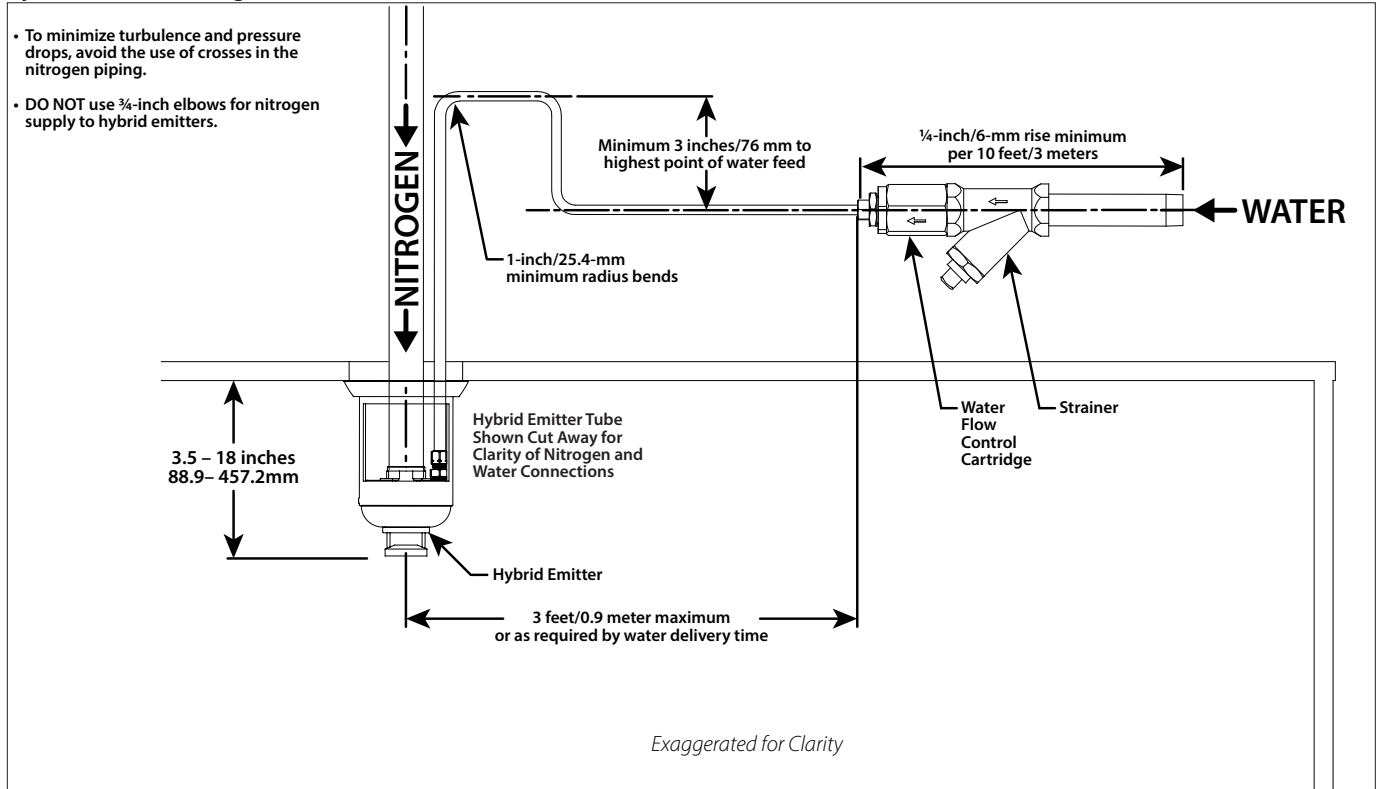

Hybrid Emitter – Plenum Detail

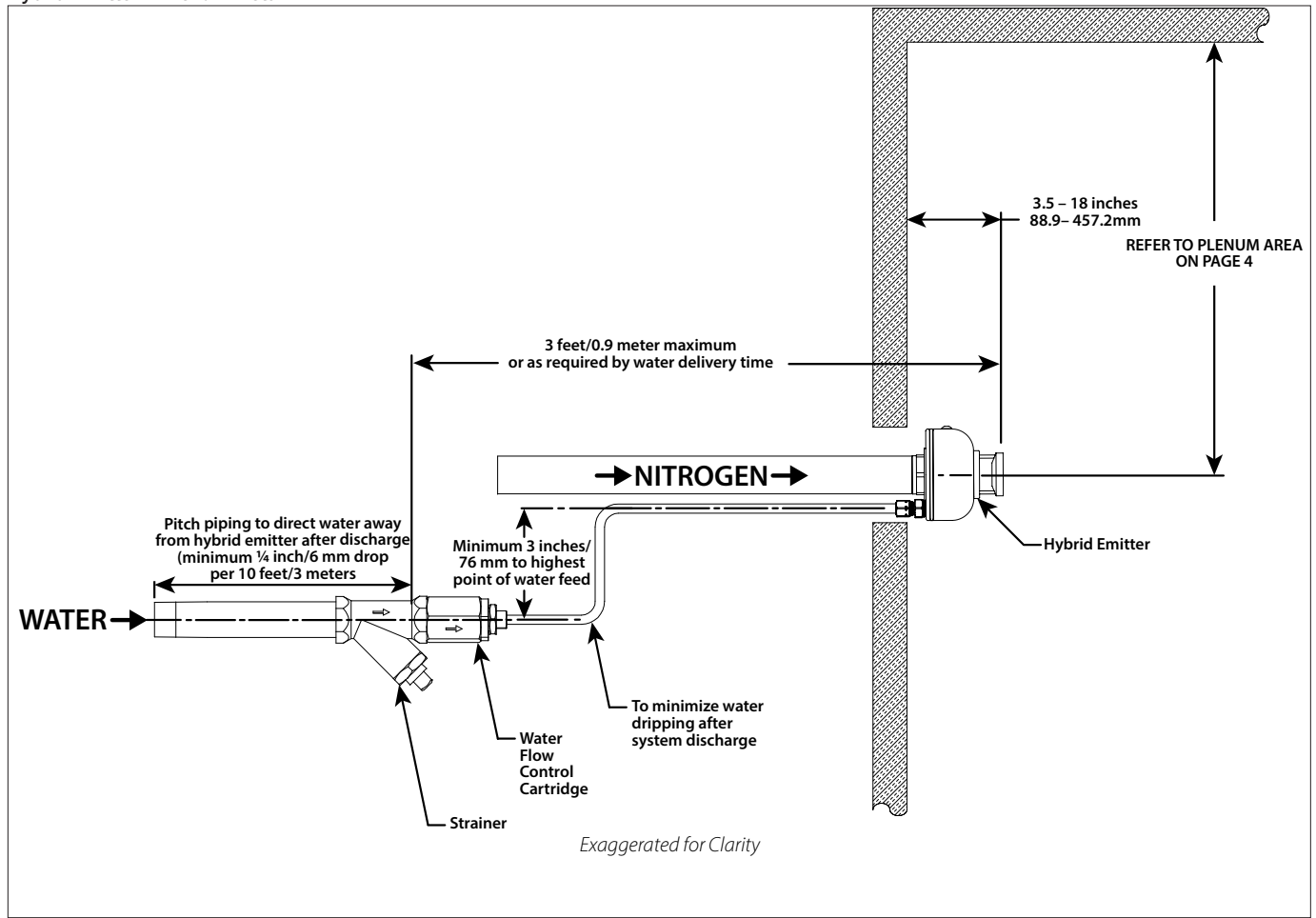

PRESSURE TRANSDUCER LOCATION

The ARV in the Victaulic Vortex™ Panel regulates nitrogen pressure based on feedback from the pressure transducer. Hybrid emitters farthest from the pressure transducer will have greater differences from the set pressure. Friction losses will cause pressure drop in the nitrogen piping and cause small differences in actual pressure at each hybrid emitter.

The pressure transducer reads pressure at a single point in the system and should be located to read the average pressure of the hybrid emitters. If needed, the set pressure of the Combination or Fluid Panel may be adjusted to make up for additional pressure losses beyond the pressure transducer.

In zoned systems utilizing Fluid and Zone Panels, the pressure transducer shall be located between the Fluid and Zone Panels. Avoid direction changes and use sufficiently large pipe sizes in order to minimize pressure drops in zoned systems.

The pressure transducer shall be located in an area to minimize risk of damage during a fire event. **NOTE:** A pressure transducer with an explosion-proof rating is available as an option.

NITROGEN PIPING LAYOUT PROCEDURES

1. Determine hybrid emitter placement.
2. Determine the location of Victaulic Vortex™ Panels and nitrogen supply. **NOTE:** Combination Panels shall be located lower than the hybrid emitters to allow for water line drainage after discharge, or an electric drain valve will be required at the system's lowest points.
3. Determine nitrogen piping layout.
4. Determine pipe sizes for the high (upstream of Victaulic Vortex™ Panel) and low (downstream of Victaulic Vortex™ Panel) pressure pipe networks based on the flow tables on the following page. **NOTE:** These flow tables are intended for general guidance. A system designer/integrator shall calculate pressure loss throughout the nitrogen piping.
5. Determine the highest and lowest pressure hybrid emitters based on nitrogen piping layout.
6. Determine the pressure transducer pressure setting.
7. Determine the Victaulic Vortex™ Panel outlet pressure. **NOTE:** The outlet pressure shall be less than 65% of the Victaulic Vortex™ Panel's maximum outlet pressure.
8. Determine the end-of-discharge cylinder pressure.
9. The system may be modeled in the VTHS software to verify nitrogen pressure calculations.

NOTICE

- The following flow tables are intended for general guidance, and they are to be used as a starting point for new designs. Specific system conditions, or other factors, may allow use of larger or smaller pipe diameters. A system designer/integrator shall calculate pressure loss throughout the nitrogen piping and verify the piping design is adequate for the expected operating conditions and intended use.

MAXIMUM RECOMMENDED NITROGEN FLOW ACCORDING TO PIPE SIZE

EMITTER GRID (Low-Pressure Piping)

The pipe sizes listed in this table are minimum and are based on Schedule 10 pipe at 70°F/21°C with a pipe roughness of 0.0018 inches/.05 mm. It is assumed that the inlet pressure is 30 psig/2.1 Bar. The flow rates listed are approximately 10% pressure loss across the length of the straight pipe.

Pipe Size inches	Maximum Recommended Nitrogen Flow (10 feet) SCFM	Maximum Recommended Nitrogen Flow (20 feet) SCFM	Maximum Recommended Nitrogen Flow (30 feet) SCFM	Maximum Recommended Nitrogen Flow (40 feet) SCFM
1	260	180	145	125
1 ¼	530	370	300	260
1 ½	790	555	450	390
2	1520	1060	860	745
2 ½	2550	1800	1450	1250
3	4450	3125	2530	2180

MAXIMUM RECOMMENDED NITROGEN FLOW ACCORDING TO PIPE SIZE

DOWNSTREAM OF VICTAULIC VORTEX™ PANEL (Panel to Hybrid Emitter Grid)

The pipe sizes listed in this table are minimum and are based on Schedule 10 pipe at 70°F/21°C with a pipe roughness of 0.0018 inches/.05 mm. It is assumed that the inlet pressure is 50 psig/3.4 Bar. The flow rates listed are approximately 20% pressure loss across the length of the straight pipe.

Pipe Size inches	Maximum Recommended Nitrogen Flow (20 feet) SCFM	Maximum Recommended Nitrogen Flow (50 feet) SCFM	Maximum Recommended Nitrogen Flow (100 feet) SCFM	Maximum Recommended Nitrogen Flow (500 feet) SCFM
1	400	250	170	75
1 ¼	800	500	350	150
1 ½	1200	750	530	230
2	2300	1500	1000	440
2 ½	3900	2500	1700	740
3	6800	4300	3000	1300
4	13500	8500	6000	3600
6	39000	24000	17000	7300
8	80000	49000	34000	14500

MAXIMUM RECOMMENDED NITROGEN FLOW ACCORDING TO PIPE SIZE

UPSTREAM OF VICTAULIC VORTEX™ PANEL (High-Pressure Piping)

The pipe sizes listed in this table are minimum and are based on Schedule 160 pipe at 70°F/21°C with a pipe roughness of 0.0018 inches/.05 mm. It is assumed that the inlet pressure is 300 psig/20.7 Bar. The flow rates listed are approximately 20% pressure loss across the length of the straight pipe.

Pipe Size inches	Maximum Recommended Nitrogen Flow (20 feet) SCFM	Maximum Recommended Nitrogen Flow (50 feet) SCFM	Maximum Recommended Nitrogen Flow (100 feet) SCFM	Maximum Recommended Nitrogen Flow (500 feet) SCFM
1	1000	625	440	200
1 ¼	2500	1560	1100	500
1 ½	3600	2300	1600	710
2	6600	4200	3000	1300
2 ½	12000	7600	5500	2400
3	21000	13500	9500	4200
4	42500	27000	19000	8500
6	125000	80000	55000	25000

EVALUATION OF A LOW-PRESSURE NITROGEN PIPING NETWORK

NOTICE

- Refer to the applicable Victaulic White Paper for additional information.

Evaluation of a low-pressure nitrogen piping network requires:

1. Verification that pressure drops between (closest and furthest) hybrid emitters are low enough to allow all hybrid emitters to be within pressure tolerance.
2. Verification that the pressure drop between the pressure transducer and hybrid emitters is known, so that the pressure transducer's pressure can be set.
3. Verification that the losses from the Victaulic Vortex™ Panel to the pipe network are minimized, so that the Victaulic Vortex™ Panel's maximum allowed outlet pressure is not exceeded.

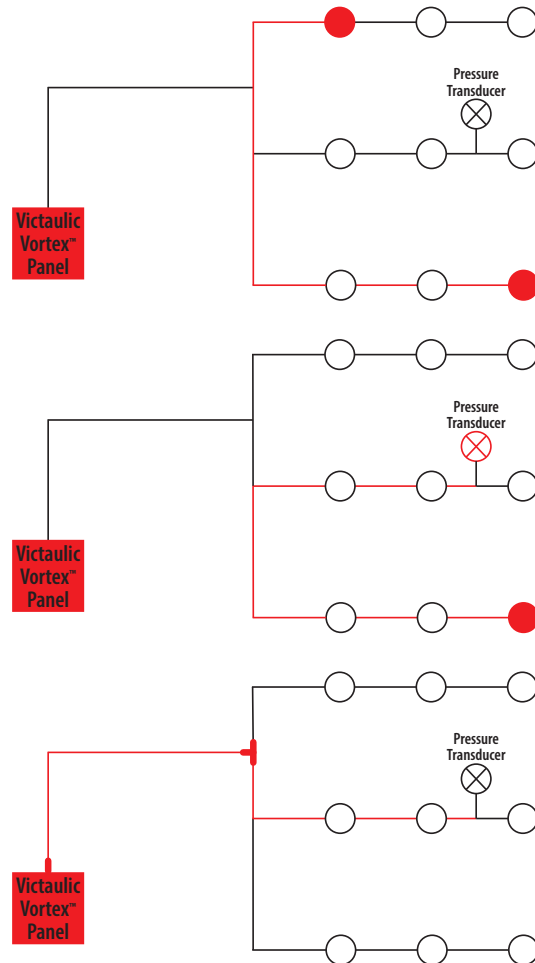

SYSTEM REFILL

Victaulic recommends refilling any nitrogen cylinder that is more than 10%, corrected for temperature, below the fill pressure for which the system is designed. Cylinder valves are tested to have a leakage rate of less than 0.15% per year.

System design documentation shall include quantity of inert gas and water required, along with the required nitrogen pressure and refill pressure. In addition, system design shall include plans for refilling the system in the event of discharge or loss of nitrogen supply pressure due to normal maintenance and operations. In critical applications or remote locations, it may be desirable to have a connected nitrogen reserve that can be placed in service quickly. Identify and contact a compressed gas supplier that can provide nitrogen for system refill, and to determine delivery times and any special equipment required.

A typical connected reserve includes a complete second set of cylinders, manifold, and primary/secondary kits that can be connected to Victaulic Vortex™ Panels by opening and closing the appropriate nitrogen isolation valves.

If a connected reserve is not used, consider maintaining a second set of filled nitrogen cylinders that may be exchanged with empty cylinders after a system discharge.

If individual high-pressure cylinders are used for the nitrogen supply, cylinders may be removed from the rack and transported to a compressed gas supplier to refill cylinders individually. A refill adapter assembly, as shown in the installation operation maintenance manual, is required. Consider ordering and having refill adapter assemblies readily available on site for gas supplier use.

High-pressure cylinders may be refilled in place from a high-pressure nitrogen source, such as a nitrogen tube trailer, using the manifold fill assembly described in Section II of the I-VORTEX.IOM. This method allows for connection of a nitrogen tube trailer to the Victaulic Vortex™ manifold to fill all of the cylinders simultaneously through the manifold. High-pressure piping is required to an accessible location outside the building for a nitrogen tube trailer. Additionally, high-pressure hose and adapters may be required to connect to the tube trailer. Contact your local compressed gas supplier for complete requirements.

Refer to the Victaulic Vortex™ Hybrid Fire Extinguishing System Installation, Operation, and Maintenance Manual for nitrogen refill procedures.

SYSTEM SIGNAGE

All control, drain, and test connection valves shall be marked with appropriate identification signs. System documentation shall include location and description of water and inert gas supplies, as well as location of control, drain, and test connection valves.

VICTAULIC TOOLS FOR HYBRID SYSTEMS (VTHS)

NOTICE

- Data for Victaulic Vortex™ systems, provided within the VTHS report, are for informational purposes only. FM Approved Victaulic Vortex™ systems shall be designed in accordance with the most current version of the Victaulic Vortex™ General Design Manual and applicable FM Global Loss Prevention Data sheets.

Victaulic Tools for Hybrid Systems (VTHS) is a UL Verified software package to aid in the design of Victaulic Vortex™ Hybrid Fire Extinguishing Systems. VTHS provides tools to lay out the pipe network, calculate nitrogen emitter pressures, calculate water delivery time, and generate reports. The report includes details about the system, isometrics, and calculation results, along with a bill of materials.

The following screenshots are provided as an overview. Always reference the I-VORTEX.VTHS manual for details on how to utilize the software.



Victaulic Tools for Hybrid Systems

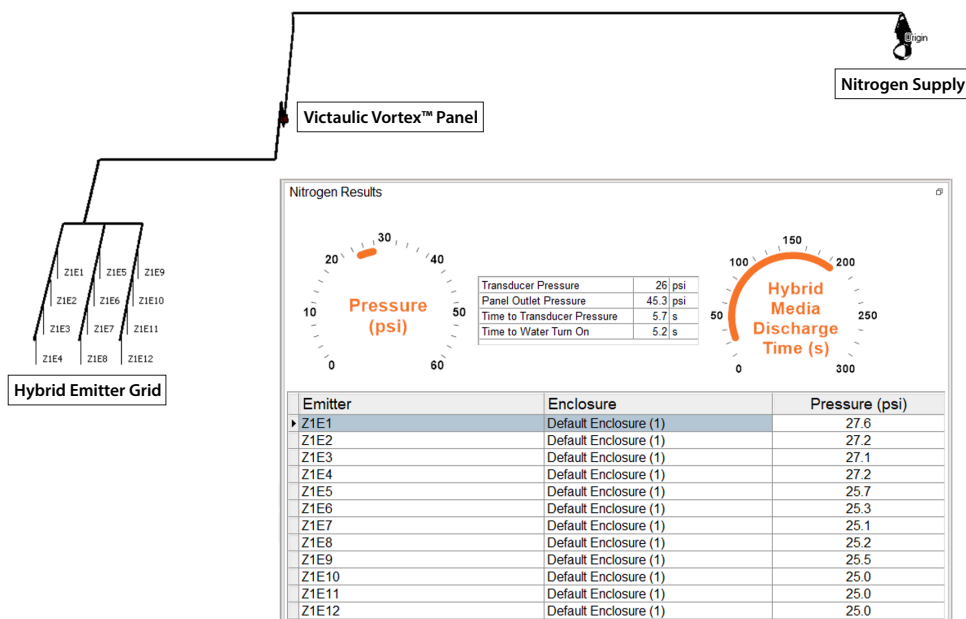
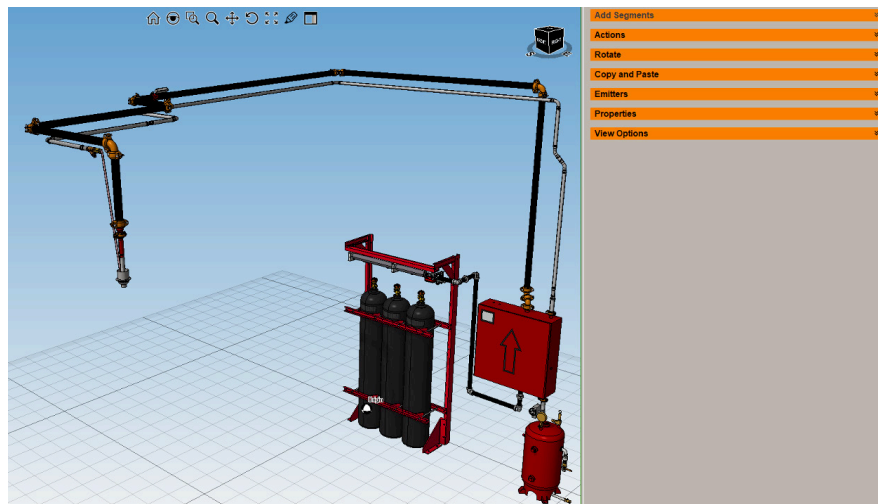

Design Review

Zones:

Enclosures:

No. Emitters:

Summary

Description	Minimum	Maximum	Provided	Units	
▶ Total Usable Volume	8104		8466	scf	✓
Cylinder Storage Rack Space	17		18		✓
Panel Nitrogen Flow Rate	2760		4500	scfm	✓
Water Volume	20		30	gal	✓
Estimated Discharge Time	126	198	184	s	✓
Estimated Oxygen Level - Default Enclosure (1)			13.1	%	

Hardware

Description	Category	Quantity
5/8" Emitter, 954 cavity foil, standard, stainless	Emitters	12
Victaulic Vortex Nitrogen Cylinder with Release Valve, Filled 80L	Cylinders	17
Cylinder Storage Rack, 80L, Structural, Red Painted (12 pack 6x2) w/ tw...	Cylinder Storage	1
Cylinder Storage Rack, 80L, Structural, Red Painted (6 cylinder 3x2) w/ si...	Cylinder Storage	1
V1500, Vortex Panel Wired Assembly, Combination, Active Release, 1-1/2"	Panels	1
▶ 30 gallon, Red, Water Tank with Trim, ASME	Water Tanks	1

Settings

- ▼ (Defaults)
 - (Default Units)
 - Designer
 - Use Large Navigation Tiles
- ▼ (Project)
 - (Units)
 - Ambient Pressure (psia)
 - Ambient Temperature (F)
 - Max Simulation Time (s)
- ▼ Design
 - Nitrogen Safety Factor
 - Water Safety Factor
- ▼ Standard Conditions
 - Standard Gas Pressure (psia)
 - Standard Gas Temperature (F)

Flow Calculations

Active Zones:

Calculation Mode:

Status Results

Results Displayed:

Nitrogen Results

Pressure (psi)

Transducer Pressure	24 psi
Panel Outlet Pressure	42 psi
Time to Transducer Pressure	9.8 s
Time to Water Turn On	9.2 s

Discharge Duration (s)

Water Results

Pressure (psi)

Volume (gal)

Delivery Time (s)

6.0 Calculation Results

6.1 Calculation Inputs

Calculation Date: May 25, 2022 Version: 1.0.0

Active Zones: Default Zone [1]

Water Pressure Setting: 125.0 psi

Panel Settings

Panel	Zone	Nitrogen Pressure	Water Turn On Pressure
Panel-21	1	25.0 psi	13.0 psi

6.2 System Results

Nominal Nitrogen Flow Rate: 2843.0 scfm Nominal Water Flow Rate: 3.1 gpm

Total Nitrogen Volume: 8701 scf Total Water Volume: 9.4 gal

Discharge Duration*: 206 s Water Delivery Time**: 30.5 s

Nitrogen Calculation: Compressible gas flow calculation built on the conservation of mass, momentum, and energy assuming subsonic flow and standard pipe properties.

Water Calculation: The transient portion of the water flow calculation uses an unsteady, one-dimensional formulation of the Bernoulli equation along a streamline to describe the water flow along the pipes. The steady state portion of the water flow calculation uses a one-dimensional node-based approach. The friction loss is calculated using the Darcy friction factor.

See the Victaulic Tools for Hybrid Systems Software User Guide for a more detailed description of the calculations used.

* Discharge duration is the time from system activation (release signal) until the hybrid media discharge ends.

** Water delivery time is from system activation (release signal) until water reaches hydraulically furthest emitter. Refer to panel settings for when the water valve will begin opening.

6.3 Enclosure Results

Enclosure	Nitrogen Volume	Water Volume	Oxygen Level
Default Enclosure (1)	8701 scf	9.4 gal	12.9%

GENERAL SAFETY REQUIREMENTS

1. **Read and understand all instructions before proceeding with installation and maintenance of this Victaulic Vortex™ system.**
2. **Inspect the shipment.** Verify that all components are included in the shipment and that all necessary tools are available for installation.
3. **Use only recommended accessories.** Accessories and equipment that are not approved for use with this hybrid fire extinguishing system may cause improper system operation.
4. **Wear safety glasses, hardhat, foot protection, and hearing protection.** Wear hearing protection if you are exposed to long periods of noisy job-site operations.
5. **Prevent back injury.** Always practice proper lifting techniques.
6. **Avoid using electrically powered tools in dangerous environments.** When using electrically powered tools for installation, verify that the area is moisture-free. Keep the work area well lit, and allow enough space to accommodate installation of the hybrid fire extinguishing system.
7. **Keep work areas clean.** Cluttered areas, benches, and slippery floors can create hazardous working conditions.
8. **PROTECT THE SYSTEM FROM FREEZING CONDITIONS. THE WATER SUPPLY AND WATER SUPPLY PIPING SHALL BE PROTECTED FROM FREEZING TEMPERATURES AND MECHANICAL DAMAGE. COMBINATION, FLUID, AND ZONE PANELS ARE NOT RATED FOR OUTDOOR USE.**

SAFETY REQUIREMENTS DURING MAINTENANCE AND TESTING

1. **Notify the authority having jurisdiction (AHJ).** Always notify the AHJ before performing any maintenance that takes the system out of service.
2. **Follow the requirements set forth in this manual and by the AHJ for system inspection schedules.** The facility or process owner or their representative is responsible for inspecting the system in accordance with the requirements set forth in this manual and by the local AHJ.
3. **Inform personnel of any testing or of the potential for a system discharge.** Vacate all personnel or provide appropriate personal protection for all personnel during testing or system discharge.
4. **Depressurize or isolate the water supply completely and isolate the nitrogen cylinders before performing any maintenance.**
5. **Protect the system from freezing temperatures, foreign matter, and corrosive atmospheres.** Any condition that might degrade the system or affect system performance shall be avoided.

NITROGEN GAS SAFETY REQUIREMENTS

1. **A sudden release of high pressure from a nitrogen gas cylinder can result in death or serious personal injury.** Always verify that components, valves, and hoses are installed and in proper condition. All cylinder connections and bracing SHALL be installed and tightened.
2. **Cylinder caps shall be installed when transporting or storing nitrogen gas cylinders.** DO NOT use cylinder caps as a lifting point.
3. **Nitrogen gas cylinders shall be secured to prevent them from falling over.** Store nitrogen gas cylinders in a well-ventilated area. Verify that cylinder valves are safety tied closed.
4. **Cylinders containing compressed nitrogen gas are heavy and awkward to handle.** Improper handling of nitrogen gas cylinders could result in serious personal injury.

NOTICE

- **Adequate ventilation shall be provided in the nitrogen storage area in case of a nitrogen leak.**
- **Low nitrogen pressure at the cylinders may indicate low oxygen in the nitrogen storage area.**

5. **In the event of a nitrogen gas cylinder leak, personnel not wearing protective equipment shall leave immediately and be restricted from the area until it has been ventilated properly, the leak has been repaired, and oxygen levels have been restored.**
6. **Audible and visible discharge alarms shall be provided within the hazard zone to ensure prompt evacuation of the hazard zone and to prevent entry into the hazard zone in the event that the Victaulic Vortex™ system activates.** The system shall comply with applicable local and national codes. Safety items such as personnel training, warning signs, discharge alarms, self-contained breathing apparatus (SCBA), evacuation plans, and fire drills shall be considered.

SAFETY SIGNAGE/PLACARDS

Victaulic Vortex™ Panel Nameplate

Each Victaulic Vortex™ system will contain a nameplate, similar to what is shown below, that is affixed to the Victaulic Vortex™ Panel.

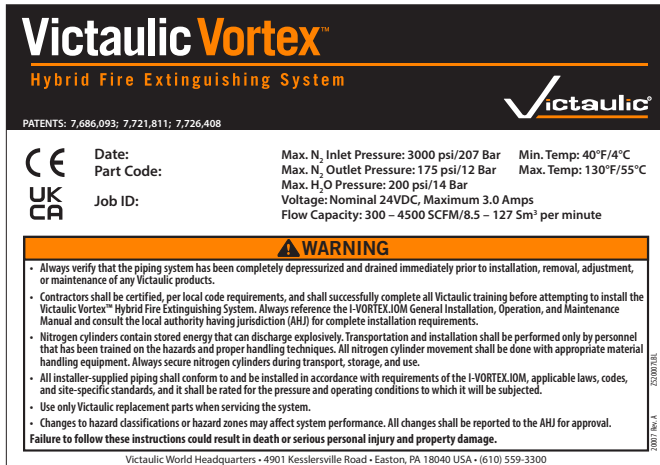

Victaulic Vortex™
Hybrid Fire Extinguishing System

PATENTS: 7,686,093; 7,721,811; 7,726,408

CE Date: Max. N₂ Inlet Pressure: 3000 psi/207 Bar Min. Temp: 40°F/4°C
UK Part Code: Max. N₂ Outlet Pressure: 175 psi/12 Bar Max. Temp: 130°F/55°C
CA Job ID: Max. H₂O Pressure: 200 psi/14 Bar
Voltage: Nominal 24VDC, Maximum 3.0 Amps
Flow Capacity: 300 – 4500 SCFM/8.5 – 127 Sm³ per minute

WARNING

- Always verify that the piping system has been completely depressurized and drained immediately prior to installation, removal, adjustment, or maintenance of any Victaulic products.
- Contractors shall be certified, per local code requirements, and shall successfully complete all Victaulic training before attempting to install the Victaulic Vortex™ Hybrid Fire Extinguishing System. Always reference the I-VORTEX.IOM General Installation, Operation, and Maintenance Manual and consult the local authority having jurisdiction (AHJ) for complete installation requirements.
- Nitrogen cylinders contain stored energy that can discharge explosively. Transportation and installation shall be performed only by personnel that has been trained on the hazards and proper handling techniques. All nitrogen cylinder movement shall be done with appropriate material handling equipment. Always secure nitrogen cylinders during transport, storage, and use.
- All installer-supplied piping shall conform to and be installed in accordance with requirements of the I-VORTEX.IOM, applicable laws, codes, and site-specific standards, and it shall be rated for the pressure and operating conditions to which it will be subjected.
- Use only Victaulic replacement parts when servicing the system.
- Changes to hazard classifications or hazard zones may affect system performance. All changes shall be reported to the AHJ for approval.

Failure to follow these instructions could result in death or serious personal injury and property damage.

Victaulic World Headquarters • 4901 Kesslersville Road • Easton, PA 18040 USA • (610) 559-3300

Victaulic Vortex™ Design Method Nameplate

Each Victaulic Vortex™ system will ship with a design method nameplate for the protection of data processing halls that shall be placed on each of the Victaulic Vortex™ Panels directly underneath the Victaulic Vortex™ Panel Nameplate.



Victaulic Vortex™
Hybrid Fire Extinguishing System

For protection of wet bench applications and similar processing equipment

Design Manual: VDM-VORTEX.04
General Installation, Operation, and Maintenance Manual: I-VORTEX.IOM

FM APPROVED

Nitrogen Cylinder Rack Warning Placard

Each Victaulic Vortex™ system will ship with a nitrogen cylinder rack warning placard that shall be attached to the cylinder rack.

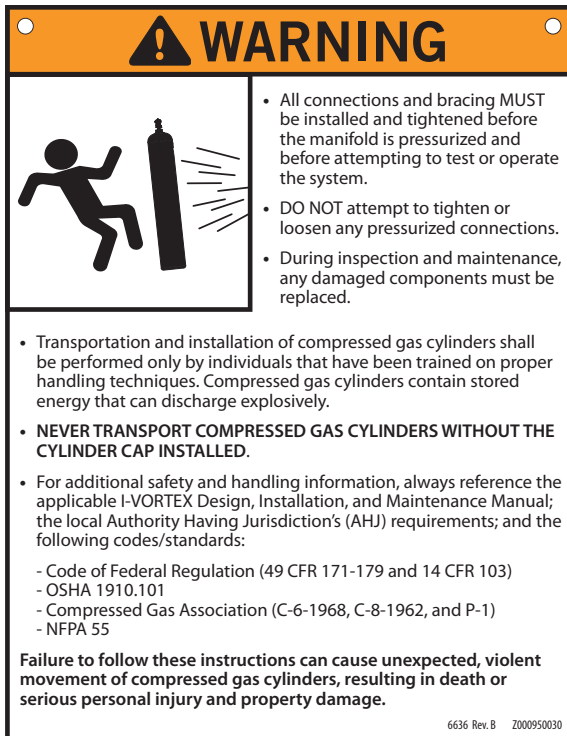

WARNING



- All connections and bracing **MUST** be installed and tightened before the manifold is pressurized and before attempting to test or operate the system.
- DO NOT attempt to tighten or loosen any pressurized connections.
- During inspection and maintenance, any damaged components must be replaced.

- Transportation and installation of compressed gas cylinders shall be performed only by individuals that have been trained on proper handling techniques. Compressed gas cylinders contain stored energy that can discharge explosively.
- NEVER TRANSPORT COMPRESSED GAS CYLINDERS WITHOUT THE CYLINDER CAP INSTALLED.**
- For additional safety and handling information, always reference the applicable I-VORTEX Design, Installation, and Maintenance Manual; the local Authority Having Jurisdiction's (AHJ) requirements; and the following codes/standards:
 - Code of Federal Regulation (49 CFR 171-179 and 14 CFR 103)
 - OSHA 1910.101
 - Compressed Gas Association (C-6-1968, C-8-1962, and P-1)
 - NFPA 55

Failure to follow these instructions can cause unexpected, violent movement of compressed gas cylinders, resulting in death or serious personal injury and property damage.

6636 Rev. B Z000950030

Hazard Zone Warning Placards

System warning placards shall be posted within and outside the hazard zone. Victaulic has hazard zone warning placards that are available for ordering by contacting your local Victaulic sales representative. The system designer/integrator should consider the type and amount of hazard zone warning placards that are required. **NOTE:** Placards that are deemed necessary by the system designer/integrator, building owner, or AHJ may be used in lieu of the Victaulic versions.

Placard for Within the Protected Space

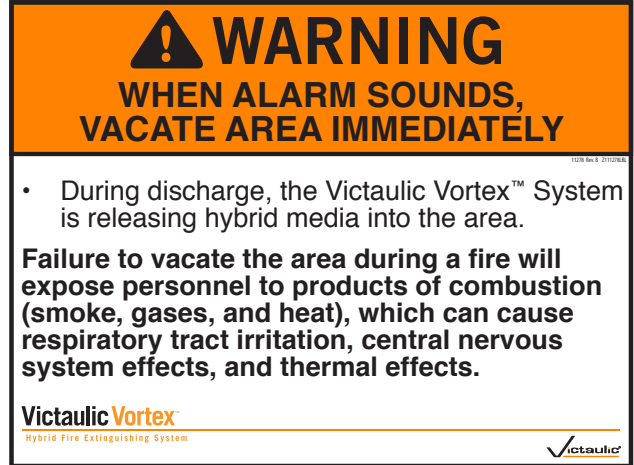

WARNING

WHEN ALARM SOUNDS, VACATE AREA IMMEDIATELY

- During discharge, the Victaulic Vortex™ System is releasing hybrid media into the area.

Failure to vacate the area during a fire will expose personnel to products of combustion (smoke, gases, and heat), which can cause respiratory tract irritation, central nervous system effects, and thermal effects.

Victaulic Vortex™
Hybrid Fire Extinguishing System

Placard for Outside the Protected Space

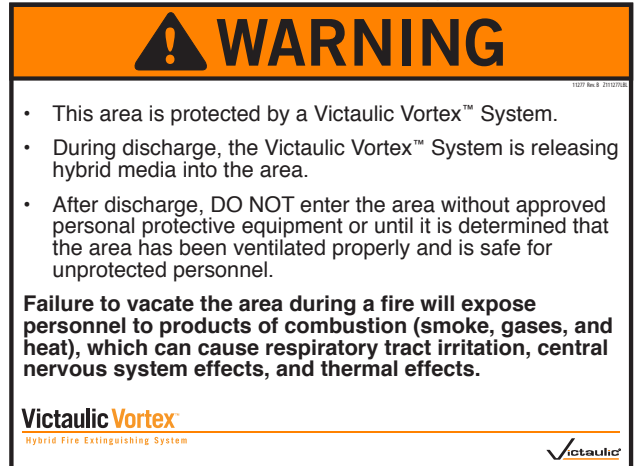

WARNING

- This area is protected by a Victaulic Vortex™ System.
- During discharge, the Victaulic Vortex™ System is releasing hybrid media into the area.
- After discharge, DO NOT enter the area without approved personal protective equipment or until it is determined that the area has been ventilated properly and is safe for unprotected personnel.

Failure to vacate the area during a fire will expose personnel to products of combustion (smoke, gases, and heat), which can cause respiratory tract irritation, central nervous system effects, and thermal effects.

Victaulic Vortex™
Hybrid Fire Extinguishing System

Manual Pull Station Placard

Victaulic has a manual pull station placard available for order. The system designer/integrator should consider the amount of manual pull station placards that are required. **NOTE:** A placard that is deemed necessary by the system designer/integrator, building owner, or AHJ may be used in lieu of the version that Victaulic has available for order.

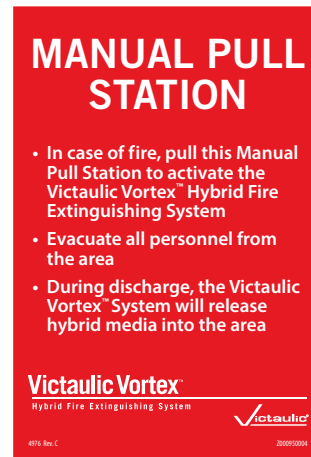

MANUAL PULL STATION

- In case of fire, pull this Manual Pull Station to activate the Victaulic Vortex™ Hybrid Fire Extinguishing System
- Evacuate all personnel from the area
- During discharge, the Victaulic Vortex™ System will release hybrid media into the area

Victaulic Vortex™
Hybrid Fire Extinguishing System

Victaulic Vortex™ Hybrid Fire Extinguishing System

For Protection of Wet Bench Applications and Similar Processing Equipment



For complete contact information, visit victaulic.com

VDM-VORTEX.04 20144 REV A UPDATED 03/2024 Z000VDM004

VICTAULIC AND VICTAULIC VORTEX ARE TRADEMARKS OR REGISTERED TRADEMARKS OF VICTAULIC COMPANY AND/OR ITS AFFILIATED ENTITIES IN THE UNITED STATES AND/OR OTHER COUNTRIES. © 2024 VICTAULIC COMPANY. ALL RIGHTS RESERVED.

